

FINANCE — LABOUR

1992

Hot under the white collars (54)

S. Times (Bus) 12/1/92

By ADRIAN HERSCH

WHITE-COLLAR militancy appears to be growing.

A strike ballot is being held among First National Bank employees — and one is looming at the Perm.

Both disputes relate to the annual pay talks.

The SA Society of Bank Officials (Sasbo) wants a 16% increase — FNB offers 13%.

The discussions affect 25 000 employees.

Sasbo general secretary Ben Smith says that in 1991 FNB produced a 16,8% taxed increase in profit to R385,1-million.

FNB senior general manager Jimmy McKenzie says given the state of the economy it is important the bank protect itself for the future.

"The salary bill is R1-billion a year. Each 1% increase involves a large sum."

The outcome of the strike ballot will be known on February 4.

Mediation failed to resolve the dispute between the Perm and the Building Society Officials Association (Bsoa).

Management offers a 10% rise, but the union wants 12%.

The Perm says in a hand-out to employees that a housing allowance — to those who did not previously benefit — is the equivalent of a 1,6% addition to the salary bill.

A union circular says the Perm has implemented its final offer to non-union members with effect from January 1.

The circular also says the Bsoa received a "positive response" to an "opinion poll" about industrial action.

Estate agents' diploma introduced in SA

B 10 am 15/1/92
AN internationally recognised diploma course for estate agents is being offered for the first time in SA.

The CRB Property Diploma course, sponsored by the Perm and endorsed by the National Property Academy and Institute of Estate Agents of SA, will start in February.

The course was designed in the US by real estate experts and covers all areas of SA real estate including residential, commercial and industrial business.

The course may be completed in two-, three- or four-year modules, and after

completion participants will be awarded full membership of the faculty.

Drexanne Evers, senior faculty instructor of the US CRB Teaching Academy, will be teaching the course that runs in Johannesburg, Cape Town and Durban.

Evers, who holds an MBA, was co-author of the book on top residential property negotiators, *Tips from the Top*.

Further information can be obtained from Terry Ash at (011) 674-5321.

JONO WATERS

Financial institution staff pay levels decline

AVERAGE monthly pay levels at financial institutions declined in real terms during the third quarter of 1991. *Sunday 20/11/92*

Salaries and wages of banking institution, building society and insurance company staff fell 1,3% when inflation was taken into account in the third quarter compared with the second quarter.

Central Statistical Service (CSS) figures show that after adjustments for inflation, salaries and wages in banking institutions were down 3,8% in the quarter ended September, and 4,3% in the year to September.

When compared with second quar-

SHERIDAN CONNOLLY

ter figures, building society salaries and wages dropped 2,1%. Pay was also lower in insurance companies (1,8%). The number of full-time employees in banking institutions stood at 95 140 in the third quarter against 94 962 in the second quarter and 95 182 a year earlier.

General secretary of the SA Society of Bank Officials (Sasbo) Ben Smith said the decline in real monthly salaries was a reflection of average salary levels not keeping pace with inflation. The decline in salaries could also be influenced by fluctua-

tions in the number of employees.

Sasbo was conducting a strike ballot on behalf of FNB employees following a breakdown in salary negotiations. A deadlock was declared in November when FNB offered employees a 13% pay rise against Sasbo demands for 16%.

The outcome of the strike ballot at 24 Sasbo branches around the country should be made known on February 4, and the union was confident that its FNB members would vote in favour of industrial action, Smith said.

FNB increased its profits in 1991 by 16,8% to R385,1m from R329,8m in 1990.

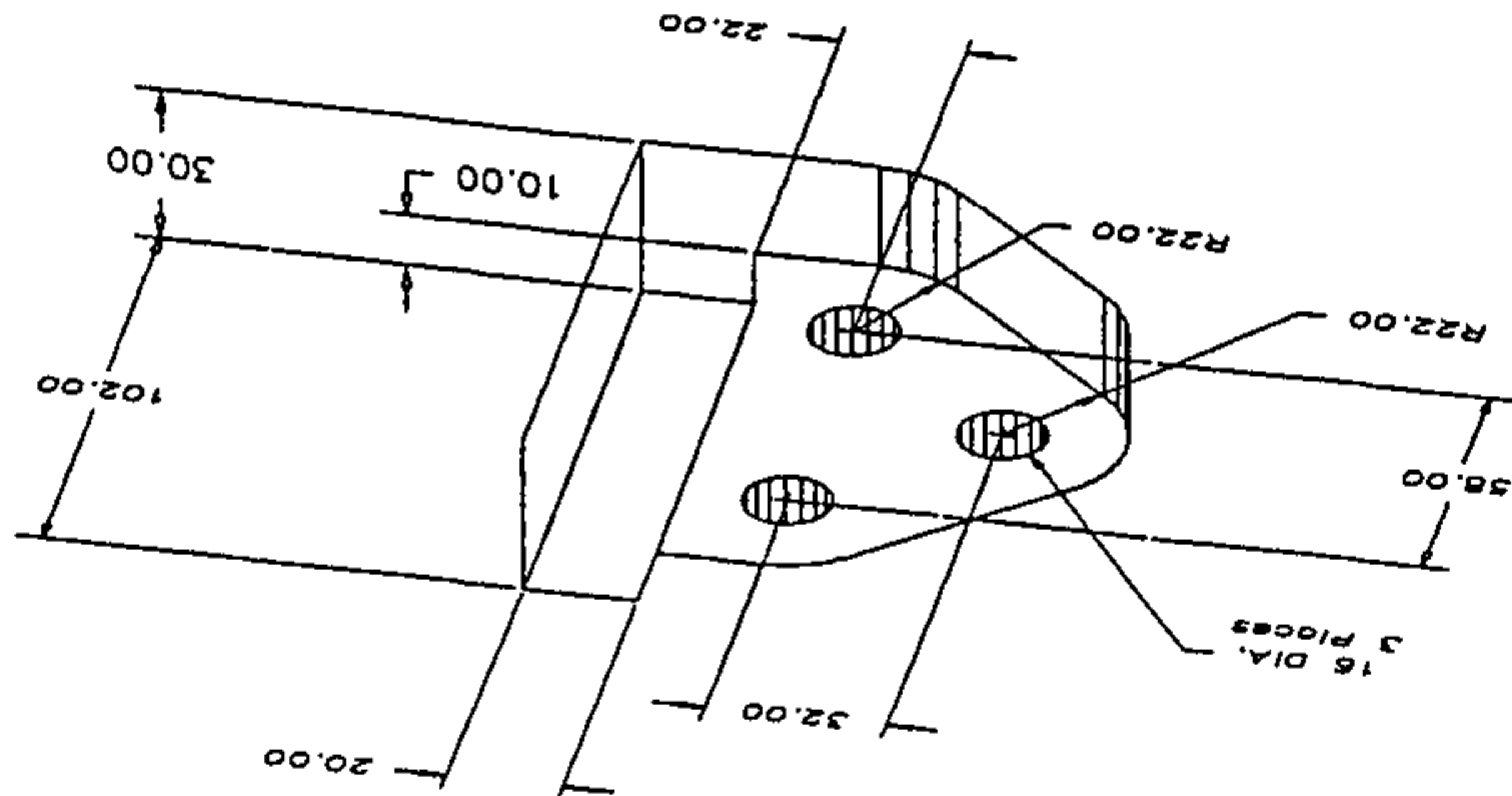

Sanlam investigates life policies after five killed in minibus crash

ANLAM yesterday launched an investigation into all life insurance policies sold by two employees allegedly implicated in the deaths on Sunday, January 19, of five black men to whom they had issued policies a week earlier.

The men died when a minibus bought by the two Sanlam employees crashed into a ravine near Witbank. The victims had been recruited through the Manpower Department to sell clothes and were being taken from Luijperds holiday resort in the eastern Transvaal to Pietersburg.

Two of the three survivors of the crash claimed at a news conference called by the ANC in Johannesburg yesterday that the minibus had been pushed into the ravine after the driver had stopped on the side of a sloping road.

The ANC named the two Sanlam men as Kobus Kruger and Lucas Loubischer. Middelburg police liaison officer Maj Schalk Plenaar said police were conducting mechanical and forensic tests on the remains of the vehicle, but no charges had been laid. Police were investigating a charge of culpable homicide.

Sanlam chief legal adviser Emil Linde

ANDREW KRUMM

said the two men joined the company less than a year ago and were still in its employment pending the outcome of its investigations.

Sanlam was investigating all similar policies sold by the two.

Sanlam had established that its two employees were the beneficiaries of policies worth R100 000 each, taken out in the names of Koos Skhosana and Samuel Matimela, both of whom survived the crash.

Through an ANC interpreter, Skhosana told the news conference that Kruger and

Loubischer contacted the men on January 2 through the Manpower Department, and offered them jobs in Pietersburg.

He said the two Sanlam employees, dressed in Defence Force uniforms, asked them to sign employment contracts and other forms. Skhosana said the two took them to the Luijperds resort near Witbank, where they were housed in an army tent.

After many delays the men were sent home with a R750 cheque. They were also given R20 in cash for each delay. They returned to the resort on January 18.

Skhosana said the minibus had black

spray-painted windows which did not open, and a wooden partition between the driver's and passenger seats. He said the handle had been removed so that passengers could not open the door from the inside, and two 25-litre petrol cans and two gas cylinders had been placed in the back.

Loubischer drove the minibus, and Kruger followed in "a Jeep".

The minibus later stopped, and he heard Loubischer outside. Then the engine revved. Seconds later the minibus plunged into a ravine and burst into flames.

● Picture: Page 2

Absa to rationalise computer systems

B/Daw 30/1/92

59

Reports by
MELANIE SERGEANT

ABSA's acquisition of Bankorp will lead to major rationalisation of the new group's computer systems.

Most sources say it is too early to speculate on exact changes, but it will probably no longer be necessary for the group to have two large backbone network systems, two computer and network management centres, backup centres, and other dual facilities.

Absa group executive of management services and technology Alwyn Burger says strategies will be formulated by Absa and Bankorpdata during the next few weeks to determine changes which may be necessary.

"Fortunately," Bankorp-

data and Absa mainframe technologies are predominantly IBM or IBM compatible, and we're using the same vendors, so there shouldn't be major program rewrites or other work necessary. Overall, our technology philosophies are much the same."

However, he says there will be savings in terms of not having to double up on certain services and products.

During its own restructuring, Absa did reduce staff, but Burger points out that at least two-thirds of the staff left through "natural" means — either because of normal "turnover" or by retiring.

"We don't expect major staff reductions now, because the workload will remain the same.

"Essentially, we must do our homework. IT staff are highly skilled, and not a re-

source to meddle with. Major costs would be incurred if we retrenched and were then forced to re-employ, so we'll avoid reductions as much as possible in the short term," he adds.

Another source in Bankorp points out that Absa has become a master of rationalisation due to its own restructurings over recent months, so the process should be well-handled.

He points out that Absa and Bankorp have already been co-operating on each other's disaster recovery systems.

"The big changes will come if it's decided to cut dual facilities such as networks, management infrastructures, mainframe sites and other computer-related systems," he adds.

Bankorpdata has about 650 staff, but there are also several DP staff working in TrustBank, Senbank and Bankfin.

Horror crash 'scam': Suspects still free

THE two men accused of trying to make the deaths of their five victims appear as an accident, are still free. *31/1/92*

According to survivors the two men, Mr Lucas Loubser and Mr Isak "Kobus" Kruger, who have been suspended by Sanlam, first insured their eight victims for more than R1 million.

They then allegedly "caused" an accident near Witbank.

The minibus, into which the men had been loaded, plunged down a 30m ravine, killing five of the eight men.

Eastern Transvaal police spokesman Warrant Officer Andre van der Westhuizen confirmed that the police had not yet arrested the two men.

He said police had launched an intensive investigation into the case.

Sanlam yesterday confirmed it had suspended Loubser and Kruger.

It also offered to pay a total of R40 000 to the families of the eight crash victims "as a gesture of goodwill and to assist in defraying the funeral and medical expenses involved".

The insurance company's Mr Emil Linde said it would be "grossly unfair and totally wrong to

By SONTI MASEKO

link Sanlam, as employer, to the alleged private activities of their employees".

The news of the suspension came as Mr Jackson Mthembu of the ANC's Witbank office called on the insurance company to honour fully the insurance policies taken out on the lives of the dead men for the benefit of their families and compensate the others who were injured.

The suspension followed persistent newspaper reports on the allegations made by the survivors, Mr Lazarus Mmadi, Mr Samuel Matsimela and Mr Koos Skosana that the crash, on Sunday July 19, was not an accident.

Mthembu has reacted strongly to the news that the two alleged murder suspects were still on the loose and added that the "only logical conclusion" to infer was that the suspects had not been arrested because they were white.

He said the initial charge of culpable homicide in an incident where five people were killed was itself a gross irregularity, viewed in the light of what happened in the past in the Westdene bus disaster.

● See page 4

CRED
CARD
WELL



PHI

C

No links (59) with scam

W/Mon 31/11 - 6/2/92
TWO men, EJ Kruger and Lucas Loubser, linked to the minibus death scam near Witbank have been suspended by Sanlam.

Five men died when the minibus plunged down a cliff and burst into flames. There were three survivors. The lives of the seven men had recently been insured and Kruger and Loubser were named as the beneficiaries. They stood to gain R1-million.

Survivors said Loubser had been driving the vehicle but was not in it when it crashed. Kruger was allegedly in another vehicle following the minibus.

Sanlam has denied any links with the alleged "private activities" of its employees. The company regretted the loss of life of the five young men and the injuries of the survivors and has contributed R40 000 to assist with funeral and medical costs.

According to the police, no action has been taken against the two Sanlam agents.

Two Sanlam men beneficiaries of crash victims' policies

TWO SANLAM employees were the beneficiaries of life insurance policies issued to seven victims of a January 19 minibus crash in which five black men died, the company said yesterday.

Sanlam chief legal adviser Emnel Linde said two Sanlam Witbank employees, Kobus Kruger and Lukas Loubser, were "definitely the beneficiaries of (all) seven policies issued to the crash victims".

An ANC-arranged news conference on Tuesday heard two crash survivors describe how the minibuses in which they were travelling with six others, all employed by

R1200 311192
ANDREW KRUMM

the two Sanlam men, was allegedly pushed down a ravine as part of an insurance "swindle" to collect on life insurance policies taken out in the men's names.

Five men burnt to death in the crash, and one of the three survivors is in the Witbank Hospital with serious burns.

Linde said Loubser and Kruger had insured the lives of four of the deceased and those of the three survivors.

One of the survivors, Koos Skhosana, told

Tuesday's news conference that they met the Sanlam employees at the Pietersburg offices of the Manpower Department in November last year. They had signed employment contracts and "other" contracts to sell clothes in Pietersburg. The other contracts were later established to be insurance forms.

Skhosana said Loubser and Kruger had asked the victims to meet them at the department on January 2, which they did.

The inception date on the life policies was January 1 1992.

Linde disclosed yesterday that Sanlam

had suspended the two employees. He said this meant Loubser and Kruger had been barred from all Sanlam offices pending the outcome of investigations.

Offering condolences to the next-of-kin, Linde also announced that "as a gesture of goodwill and commiseration" Sanlam had decided to contribute R40 000 to help defray funeral and medical expenses of the families involved.

Middelburg police said mechanical and forensic experts were investigating the scene of the accident. No charges had been brought yet against Kruger and Loubser.

FM 31/1/92

EAGLE'S BYTE

59

Technological advancement has its price, in the short term, at least.

Insurance company SA Eagle's decision to install an integrated computer network throughout its branches over the next 12 to 18 months will mean that about 20% of its work force — 300 to 360 people — will be laid off over that period.



Martin

"While we are deeply sorry to have to take these steps," says MD Peter Martin, "the company has a responsibility to remain a productive, profitable organisation and it has an obligation to offer a secure, exciting future."

Certain insurers have installed computer systems that give them a slight competitive edge. This encouraged companies such as SA Eagle to appraise tech-

nology and implement long-term restructuring programmes.

To assist personnel no longer required, the company has provided a "very fair redundancy package."

Re-employment has been offered if the need for more staff arises but this seems to present few opportunities.

The new system will manage the issuing of policies, process reinsurance, administer agents' ledgers, commission and general information together with claim payments and reinsurance recoveries. This will cut document handling, ledger entries and other labour-intensive tasks.

The short-term insurer says it will help the laid-off workers to handle tax and lodge claims with the UIF. It will also be flexible and tolerant over housing loans, give people time off to look for new jobs and provide counselling.

SA Eagle has held recognition talks with the Cosatu-affiliated Saccawu union but no agreement has been signed.

Last-minute talks to ⁽⁵⁹⁾ avoid bank strike action

SHARON SOROUR
Labour Reporter AG 4/2/92

LAST-minute negotiations have taken place to avert threatened industrial action by more than 18 500 First National Bank employees, which could close branches throughout the country.

The results of a strike ballot by members of the SA Society of Bank Officials (Sasbo) — the country's oldest and biggest banking sector union — are expected to be announced today.

Yesterday union general secretary Mr Ben Smith was locked in last-minute negotiations with management, according to a union spokesman.

Earlier Mr Smith said he was confident workers would vote in favour of taking some form of industrial action.

The union accused the bank of "demotivating" its 25 000 employees by failing to keep a five-year-old "payment-on-performance" agreement and adopting a "market-related" policy for pay increases.

The members of the 38 000-strong union are demanding an increase of 16 percent on the salary bill, which is based on performance.

Management is offering an increase of 13 percent on the salary bill.

First National Bank senior general manager Mr Jimmy Mackenzie said that while he did not believe workers would vote to take industrial action, if there was "total support" for a strike, the bank would have no option but to close, review the situation and take necessary steps.

Mr Smith said bank employees felt "cheated".

Last year was another record year with bank profits rising 16,8 percent from R329,8-million to R385,1-million, Mr Smith said.

Air fares increase

F.
e
t
S
S
D
T
c
n
n
r
l
n
h
y
s
f
e
r
12
si
ir
oi
r
p
2
rc
le
le
s
b
ir
in



Demotivated staff demand 16%

Urgent talks to avert bank strike

Sowetan
LAST-MINUTE negotiations have taken place to avert a strike by more than 18 500 First National Bank employees, which could close branches throughout the country.

The results of a strike ballot by members of the SA Society of Bank Officials - the country's oldest and biggest banking-sector union - were due to be announced yesterday.

Union general secretary Mr Ben Smith was locked in last-minute negotiations with management yesterday, according to a union spokesman.

Earlier Smith said he was confident workers would vote in favour of tak-

5/2/92
Sowetan Correspondent

ing some form of industrial action. The union accused the bank of "demotivating" its 25 000 employees by failing to keep a five-year-old "payment-on-performance" agreement and adopting a "market-related" policy for pay increases.

The members of the 38 000-strong union are demanding an increase of 16 percent based on performance.

The management is offering 13 percent.

First National Bank senior general manager Mr Jimmy Mackenzie said

(10) (11) (12)
although he did not believe workers would vote to take industrial action, if there was "total support" for a strike, the bank would have no option but to close, review the situation and take necessary steps.

Smith said employees felt "cheated".

"The bank vowed not to move the goal posts if their staff achieved outstanding results. Our members accepted the challenge and have produced record profits for four consecutive years," Smith said.

Last year was another record year with bank profits rising 16,8 percent from R329,8 million to R385,1 million, Smith said.

Salary dispute at FNB has ended ⁵⁹

THE two-month dispute between the First National Bank and its employees over salary increases has ended, according to the bank's general manager of personnel affairs, Mr Colin Hunt.

Sowetan 6/2/92

The workers and First National Bank reached a deadlock in November last year when it refused to meet their demand of a 16 percent across-the-board increase, offering them a 12 percent increase instead. Hunt yesterday said the offer had now been overwhelmingly accepted.

"The offer provides for minimum increases ranging from 12 percent upwards and is based on individual performance."

(59) (52)

FNB strike averted

STAR 6/2/92
Strike action involving First National Bank's 25 000 employees has been averted following the failure of the SA Society of Bank Officials (Sasbo) to secure sufficient support for industrial action in a strike ballot.

The ballot had been held following a deadlock in pay talks between Sasbo and FNB.

The bank said in a statement yesterday that there had been "overwhelming support" among employees to ac-

cept its wage offer, made in December, of minimum wage increases ranging from 12 percent upwards, based on merit. Effective from January 1, the increases would push up the bank's wage bill by 13 percent.

A Sasbo spokesman confirmed that the union had accepted the offer.

Sasbo this week began wage talks with the Standard Bank, affecting nearly 23 000 employees.
— Staff Reporter.

No FNB strike as ballot fails

Labour Reporter

(59)

COUNTRYWIDE industrial action at First National Bank was averted when a strike ballot by thousands of employees failed to achieve the majority of votes. ARG 6/2/92

More than 18 500 members of the S A Society of Bank Officials (Sasbo) accepted management's offer of increases from 12 to 20 percent, based on performance.

This would mean a minimum cost increase to the bank of 13 percent and was effective from January 1, the bank said in a statement.

The ballot results were announced yesterday.

PROPERTY

SA estate agents to join world body

B/day 12/2/92

(59)

ESTATE agents in SA have been invited to join an international federation representing their profession.

The International Real Estate Federation (FIABCI) decided at a recent meeting of its board in Sao Paulo, Brazil, to invite an application by the Institute of Estate Agents of SA (IEASA) for "principal membership" of the international body.

FIABCI deputy world president-elect David Blumberg said approval of the application by a board meeting during the federation's world congress in Montreux, Switzerland, in May would be a formality.

Blumberg is a former South African living in Israel and has worked for many years to get SA's membership accepted.

"This is a tremendous opportunity for South Africans who are now, after years of sanctions, coming back into the international community," he says.

"There is a great deal of business to be done out there, and FIABCI provides access to it through its sub-committees, conventions and membership list."

Trevor Downing, president of the IEASA, says FIABCI is a federation of professional real estate associations, represented in 48 countries. In addition to access to international business, the feder-

Business Day Reporter

ation provides real estate agents with an effective means of communication to enable them to share their knowledge and experience.

Downing says the IEASA will now be responsible for the formation of an SA chapter of FIABCI and its administration.

Other associations in the building industry or individuals wishing to join the organisation would, in the case of estate agents, have to be members of the IEASA, or, in the case of other professions, members of their professional association.

"We are proud to be associated with an organisation which has as its members many of the foremost property and related companies in the world, representing the widest range of disciplines — from construction, engineering and development companies to architects, valuers, town planners, lawyers and brokers."

FIABCI world president Alan Hood of Britain and Blumberg will attend the IEASA annual convention at Sun City in August.

Hood has also expressed interest in meeting cabinet ministers and others involved in the housing industry.

Investing in the future

C. Press 11/3/92
THE Future Bank has struck a note for gender equality in the workplace with the appointment of marketing manager Lindiwe Kubeka.

She sees nothing unusual with the bank appointing a female in this important area of operation.

"I'm bringing expertise and knowledge to the job. What drives me essentially is that I want to make the bank a success."

In fact, gender equality is one of the ethics the Future Bank is building into its employee relations.

Operations and mar-



TOP JOB ... Dynamic Lindiwe Kubeka.

keting general manager Phillip van den Heever says: "People must be people, they must be

(S)
treated the same." *(S)*

Kubeka, a mother of three, grew up in Pimville, Soweto.

After school she cut her teeth in marketing, working for a number of companies. Her last position was working as a marketing analyst for a well-known company manufacturing multi-purpose plastic kitchenware.

You think you are not being diplomatic when you ask her age and she shoots an answer: "I'm 33 years old. I'm not scared of my age. Maybe when I hit 40 I'll start getting scared."

Who says a woman never tells her age?

(A) Metro-D (Edms.) Bpk., Posbus 1032, Nelspruit, 1200. (B) Metavia Airlines Charter. (C) Nie-vasgestelde-lugvervoerdienlisensie N220. Onder "Lugvaartuie wat gebruik gaan word" voeg by: "Beech C90 ZS-MZG".

(A) Trek Airways (Edms.) Bpk., Posbus 2758, Johannesburg, 2000. (B) Trek Airways (Edms.) Bpk./Luxavia. (C) Nie-vasgestelde-lugvervoerdienlisensie N108. Onder "Gebied wat bedien gaan word" voeg by: "Indië, Bahrein, Verenigde Arabiese Emirate". Onder "Uitgangsbasis" voeg by: "Delhi, Bombai, Bahrein, Abu Dhabi en Doebai." Onder "Tariëfskaal" voeg by:

"Roete"	Tariëf (R)	
	Enkel	Retoer
Jan Smuts—Bombay—Delhi.....	1 000	2 000
Jan Smuts—Bahrein.....	1 000	2 000
Jan Smuts—Abu Dhabi.....	1 000	2 000
Jan Smuts—Doebai.....	1 000	2 000."

Onder "Naam waaronder die lugdiens geëksploiteer word" skrap huidige en voeg by: "Trek Airways (Edms.) Bpk./Luxavia/Flitestar". Onder "Frekwensie en rooster waarvolgens die diens geëksploiteer word" voeg by: "Weeklikse retoervlugte tussen die Republiek van Suid-Afrika (Johannesburg) en Indië. Weeklikse retoervlugte tussen Johannesburg en enigeen van die volgende punte: Bahrein, Abu Dhabi of Doebai".

(6 Maart 1992)

KENNISGEWING 217 VAN 1992

DEPARTEMENT VAN MANNEKRAG

WET OP ARBEIDSVERHOUDINGE, 1956

AANSOEK OM VERANDERING VAN DIE REGISTRASIEBESTEK VAN 'N VAKVERENIGING

Ek, David William James, Nywerheidsregistrator, maak ingevolge artikel 4 (2) soos toegepas by artikel 7 (5) van die Wet op Arbeidsverhoudinge, 1956, hierby bekend dat 'n aansoek om die verandering van sy registrasiebestek ontvang is van die South African Society of Bank Officials. Besonderhede van die aansoek word in onderstaande tabel verstrek.

Enige geregistreerde vakvereniging wat teen die aansoek beswaar maak, word versoek om binne een maand na die datum van publikasie van hierdie kennisgewing sy beswaar skriftelik by my in te dien, p/a die Departement van Mannekrag, Mannekraggebou 123A, Schoemanstraat 215, Pretoria (posadres: Privaat Sak X117, Pretoria, 0001).

TABEL

Naam van vakvereniging: South African Society of Bank Officials.

Datum waarop aansoek ingedien is: 29 Januarie 1992.

Belange en gebied ten opsigte waarvan aansoek gedoen word: Persone in diens in die Finansiële Instellingsonderneming in die Republiek van Suid-Afrika.

Vir die doeleindes hiervan beteken—

"Finansiële Instellingsonderneming" die onderneming waarin werkgewers en hul werknemers met mekaar geassosieer is in 'n finansiële instelling met die doel om besigheid te dryf, en omvat dit sodanige bedrywighede indien onderneem deur 'n moedermaatskappy, geassosieerde maatskappy of filiaal van 'n finansiële instelling;

(A) Metro-D (Pty) Ltd, P.O. Box 1032, Nelspruit, 1200. (B) Metavia Airlines Charter. (C) Non-scheduled Air Transport Service License N220. Under "Aircraft to be used" add: "Beech C90 ZS-MZG".

(A) Trek Airways (Pty) Ltd, P.O. Box 2758, Johannesburg, 2000. (B) Trek Airways (Pty) Ltd/Luxavia. (C) Non-scheduled Air Transport Service Licence N108. Under "Area to be served" add: "India, Bahrain, United Arab Emirates." Under "Base of operation" add: "Delhi, Bombay, Bahrain, Abu Dhabi and Dubai". Under "Tariff of charges" add:

"Route"	Tariff (R)	
	Single	Return
Jan Smuts—Bombay—Delhi.....	1 000	2 000
Jan Smuts—Bahrain.....	1 000	2 000
Jan Smuts—Abu Dhabi.....	1 000	2 000
Jan Smuts—Dubai.....	1 000	2 000."

Under "Name under which the air service is to be operated" delete existing and add: "Trek Airways (Pty) Ltd/Luxavia/Flitestar". Under "Frequency and timetable to which the service will be operated" add: "Weekly return flights between the Republic of South Africa (Johannesburg) and India. Weekly return flights between Johannesburg and any one of the following points: Bahrain, Abu Dhabi or Dubai".

(6 March 1992)

NOTICE 217 OF 1992

DEPARTMENT OF MANPOWER

LABOUR RELATIONS ACT, 1956

APPLICATION FOR VARIATION OF SCOPE OF REGISTRATION OF A TRADE UNION

I, David William James, Industrial Registrar, do hereby, in terms of section 4 (2) as applied by section 7 (5) of the Labour Relations Act, 1956, give notice that an application for the variation of its scope of registration has been received from the South African Society of Bank Officials. Particulars of the application are reflected in the subjoined table.

Any registered trade union which objects to the application is invited to lodge its objection in writing with me, c/o the Department of Manpower, 123A Manpower Building, 215 Schoeman Street, Pretoria (postal address: Private Bag X117, Pretoria, 0001), within one month of the date of publication of this notice.

TABEL

Name of trade union: South African Society of Bank Officials.

Date on which application was lodged: 29 January 1992.

Interest and area in respect of which application is made: Persons employed in the Financial Institution Undertaking in the Republic of South Africa.

For the purposes hereof—

"Financial Institution Undertaking" means the undertaking in which employers and their employees are associated in a financial institution for the purpose of conducting business, and includes such activities if conducted by a parent company, associated company or subsidiary of a financial institution;

"finansiële instelling" —

enige instelling geregistreer ingevolge die Wet op Depositonemende Instellings, 1990 (Wet No. 94 van 1990);

'n bouvereniging geregistreer ingevolge die Wet op Onderlinge Bouverenigings, 1965 (Wet No. 24 van 1965);

'n versekeraar geregistreer ingevolge die Versekeringswet, 1943 (Wet No. 27 van 1943);

'n pensioenfondsorganisasie geregistreer ingevolge die Wet op Pensioenfondse, 1956 (Wet No. 24 van 1956);

'n onderlinge hulpvereniging geregistreer ingevolge die Wet op Onderlinge Hulpverenigings, 1956 (Wet No. 25 van 1956);

'n effekte-trustskema soos omskryf in die Wet op Beheer van Effekte-trustskemas, 1981 (Wet No. 54 van 1981);

'n eksekuteurskamer of 'n trustmaatskappy of enige ander maatskappy wat beleggings maak of enige trusteeendom in veilige bewaring hou, beheer of administreer;

'n bestuurder wat ingevolge die Wet op Deelnemingsverbande, 1981 (Wet No. 55 van 1981), 'n skema beheer of administreer;

die Reserwebank ingestel ingevolge die Wet op die Suid-Afrikaanse Reserwebank, 1989 (Wet No. 90 van 1989);

die Landbank ingestel ingevolge die Landbankwet, 1944 (Wet No. 13 van 1944);

die Ontwikkelingsbank van Suider-Afrika wat funksioneer ingevolge die Ooreenkoms vir die instelling van die Ontwikkelingsbank van Suider-Afrika, gedateer 30 Junie 1983;

die Korporasie vir Openbare Deposito's ingestel by artikel 2 van die Wet op die Korporasie vir Openbare Deposito's, 1984 (Wet No. 46 van 1984).

die Openbare Beleggingskommissarisse bedoel in artikel 2 van die Wet op die Openbare Beleggingskommissarisse, 1984 (Wet No. 45 van 1984);

enige effektemakelaars- of soortgelyke firma wat besigheid dryf op die Johannesburgse Effektebeurs ingestel ingevolge die Wet op Beheer van Effektebeurse, 1985 (Wet No. 1 van 1985);

die Kleinsake-ontwikkelingskorporasie ingestel ingevolge die Kleinsake-ontwikkelingswet, 1981 (Wet No. 112 van 1981); en

enige instelling of organisasie of maatskappy of beslote korporasie wat in die geheel of gedeeltelik deur enige van die organisasies hierbo bedoel, besit of geadministreer word en wat besigheid van enige aard hoegenaamd dryf uitsluitlik of gedeeltelik ten bate van vermeldde organisasies of enige soortgelyke organisasie.

"financial institution" means—

59

any institution registered in terms of the Deposit-taking Institutions Act, 1990 (Act No. 94 of 1990);

a building society registered in terms of the Mutual Building Societies Act, 1965 (Act No. 24 of 1965);

an insurer registered in terms of the Insurance Act, 1943 (Act No. 27 of 1943);

a pension fund organisation registered in terms of the Pension Funds Act, 1956 (Act No. 24 of 1956);

a friendly society registered in terms of the Friendly Societies Act, 1956 (Act No. 25 of 1956);

a unit trust scheme as defined in the Unit Trusts Control Act, 1981 (Act No. 54 of 1981);

a board of executors or a trust company or any other company which makes investments or keeps in safe custody, controls or administers any trust property;

a manager who, in terms of the Participation Bonds Act, 1981 (Act No. 55 of 1981), controls or administers a scheme;

the Reserve Bank established in terms of the South African Reserve Bank Act, 1989 (Act No. 90 of 1989);

the Land Bank established in terms of the Land Bank Act, 1944 (Act No. 13 of 1944);

the Development Bank of Southern Africa functioning in terms of the Agreement establishing the Development Bank of Southern Africa, dated 30 June 1983;

the Corporation for Public Deposits established by section 2 of the Corporation for Public Deposits Act, 1984 (Act No. 46 of 1984);

the Public Investment Commissioners referred to in section 2 of the Public Investment Commissioners Act, 1984 (Act No. 45 of 1984);

any stockbroking or similar firm which conducts business on the Johannesburg Stock Exchange established in terms of the Stock Exchanges Control Act, 1985 (Act No. 1 of 1985);

the Small Business Development Corporation established in terms of the Small Business Development Act, 1981 (Act No. 112 of 1981); and

any institution or organisation or company or close corporation wholly or partly owned or administered by any of the organisations referred to above, which conducts business of any nature whatsoever, solely or partly for the benefit of the said organisations or any similar organisation.

Belange en gebied ten opsigte waarvan registrasie gehou word: Persone in diens in die Finansiële Instellingsonderneming in die Republiek van Suid-Afrika.

Vir die doeleindes hiervan beteken—

“Finansiële Instellingsonderneming” die onderneming waarin werkgewers en hul werknemers met mekaar geassosieer is in ’n finansiële instelling met die doel om besigheid te dryf, en omvat dit sodanige bedrywighede indien onderneem deur ’n moedermaatskappy, geassosieerde maatskappy of filiaal van ’n finansiële instelling;

“finansiële instelling”—

enige instelling geregistreer ingevolge die Wet op Depositonemende Instellings, 1990 (Wet No. 94 van 1990);

’n bouvereniging geregistreer ingevolge die Wet op Onderlinge Bouverenigings, 1965 (Wet No. 24 van 1965);

’n versekeraar geregistreer ingevolge die Versekeringwet, 1943 (Wet No. 27 van 1943);

’n pensioenfondsorganisasie geregistreer ingevolge die Wet op Pensioenfondse, 1956 (Wet No. 24 van 1956);

’n onderlinge hulpvereniging geregistreer ingevolge die Wet op Onderlinge Hulpverenigings, 1956 (Wet No. 25 van 1956);

’n effekte-trustskema soos omskryf in die Wet op Beheer van Effekte-trustskemas, 1981 (Wet No. 54 van 1981);

’n eksekuteurskamer of ’n trustmaatskappy of enige ander maatskappy wat beleggings maak of enige trusteiendom in veilige bewaring hou, beheer of administreer;

’n bestuurder wat ingevolge die Wet op Deelnemingsverbande, 1981 (Wet No. 55 van 1981), ’n skema beheer of administreer.

Posadres van applikant: Posbus 31537, Braamfontein, 2017.

Kantooradres van applikant: Simmondsstraat 97–99, Braamfontein, Johannesburg.

Die aandag word gevestig op onderstaande vereistes van artikels 4 en 7 van die Wet:

- (a) Die mate waarin ’n beswaarmakende vakvereniging verteenwoordigend is, word ingevolge artikel 4 (4), soos toegepas by artikel 7 (5), bepaal volgens die feite soos hulle bestaan het op die datum waarop die aansoek ingedien is, en wat die lidmaatskap betref, word alleen lede wat ingevolge artikel 1 (2) van die Wet op voormelde datum volwaardige lede was, in aanmerking geneem.
- (b) Die prosedure voorgeskryf by artikel 4 (2) moet gevolg word in verband met ’n beswaar wat ingedien word.

D. W. JAMES,
Nywerheidsregistrator.
(6 Maart 1992)

Interests and area in respect of which registration is held: Persons employed in the Financial Institution Undertaking in the Republic of South Africa.

For the purposes hereof—

“Financial Institution Undertaking” means the undertaking in which employers and their employees are associated in a financial institution for the purpose of conducting business, and includes such activities if conducted by a parent company, associated company or subsidiary of a financial institution;

“financial institution” means—

any institution registered in terms of the Deposit-taking Institutions Act, 1990 (Act No. 94 of 1990);

a building society registered in terms of the Mutual Building Societies Act, 1965 (Act No. 24 of 1956);

an insurer registered in terms of the Insurance Act, 1943 (Act No. 27 of 1943);

a pension fund organisation registered in terms of the Pension Funds Act, 1956 (Act No. 24 of 1956);

a friendly society registered in terms of the Friendly Societies Act, 1956 (Act No. 25 of 1956);

a unit trust scheme as defined in the Unit Trusts Control Act, 1981 (Act No. 54 of 1981);

a board of executors or a trust company or any other company which makes investments or keeps in safe custody, controls or administers any trust property; or

a manager who, in terms of the Participation Bonds Act, 1981 (Act No. 55 of 1981), controls or administers a scheme.

Postal address of applicant: P.O. Box 31537, Braamfontein, 2017.

Office address of applicant: 97–99 Simmonds Street, Braamfontein, Johannesburg.

Attention is drawn to the following requirements of sections 4 and 7 of the Act:

- (a) The representativeness of any trade union which objects to the application shall in terms of section 4 (4) as applied by section 7 (5) be determined on the facts as they existed at the date on which the application was lodged and, as far as membership is concerned, only members who were in good standing in terms of section 1 (2) of the Act as at the aforesaid date shall be taken into consideration.
- (b) The procedure laid down in section 4 (2) must be followed in connection with any objection lodged.

D. W. JAMES,
Industrial Registrar.
(6 March 1992)

Criminal Act used to question FNB workers

CAPE TOWN — Three First National Bank (FNB) employees were subjected to an inquiry in terms of Section 205 of the Criminal Procedures Act in the Cape Town Magistrate's Court yesterday for refusing to provide the police with confidential information regarding the Gilbeys account.

The employees said it was the policy of the bank not to give confidential information about clients unless subpoenaed.

The questioning by Adv Petrus Marais of the Office for Serious Economic Offences related to the police investigation of charges of fraud and corruption against former Gilbeys bookkeeper Margaret Harding. Harding was indicted on Friday in the Cape Town Magistrate's Court to appear in the Cape Supreme Court on April 27 on charges of fraud and corruption.

She was alleged to have invested Gilbeys money on a fixed deposit basis with provisionally liquidated broking house, Fundstrust, without Gilbeys' authority and to have received commissions totalling R2,4m from Fundstrust to do so. Gilbeys had R45m invested with Fundstrust when it was provisionally wound up.

FNB manager's assistant in the Cape Town corporate branch Derek Myngaard said that Gilbeys borrowed money on a call basis from FNB up to a prearranged limit which was negotiated at a high level. Harding did the draw downs and Myngaard said he assumed she was working within the scope of Gilbeys' authorisation.

FNB cables department Martina Reinink clerk said she received the instructions from Harding to undertake the transfer of Gilbeys funds. One instruction from Harding had only one of the required two

authorised signatures and another had no signatures at all. Harding had explained this and the transfers went ahead.

The indictment against Harding said that from August 1990 Fundstrust director Ansi Kamfer began to reward Harding with cash amounts of R1 000 for maintaining the relationship between Gilbeys and Fundstrust. Up to January 1991, she accepted seven such payments.

In early 1991 Kamfer allegedly said to Harding that she would get a commission of 1% of funds placed with Fundstrust on a fixed deposit basis. Harding allegedly borrowed money on Gilbeys account on call from the money market to onlend on a fixed basis to Fundstrust.

Criteria

In her daily statements Harding allegedly omitted to mention all funds she had borrowed on a call basis for the purpose of fixing the funds with Fundstrust.

Meanwhile, in a recent circular to creditors, Fundstrust liquidators said the company's assets totalled R47m, including loans to clients of R16m, the vast majority of which "were not made on the normal lending criteria".

"Our attorneys have already been instructed to institute legal proceedings against many clients."

The provisional liquidators were reasonably certain that investors would not receive less than 35c in the rand. They were confident that a first dividend of 10c in the rand would be paid during July.

LINDA ENSOR

4 000 jobs to go in bank cuts

59

ARG 4/4/92

CLAIRE GEBHARDT

Weekend Argus Correspondent

AMALGAMATED Banks of South Africa (Absa) is on the brink of axing at least 4 000 workers.

Market speculation is that the figure could be as high as 6 000 by mid-year.

The company is expected to formally announce its plans next week.

A source within Absa said the company would make the retrenchments as humane as possible and would consider every alternative.

The cost-cutting exercise will affect the group's administration and computer staff, branch networks and head office.

The merger between Volkskas, United, Allied and Sage,

which created the Absa banking behemoth in January last year, quickly emerged as the largest, most hotly contested and confusing takeover bid in South Africa's history.

CE Piet Badenhorst stressed then that there would be no short-term slashing of staff or services. He said natural attrition would cut numbers. Talk was of rationalisation of facilities rather than staff.

But the economic downturn altered the scenario drastically.

Analysts see the SA banking sector as generally over-served, under-capitalised and under-profitable.

The most serious dimension of overbanking is over-staffing and in June last year Absa announced that staff numbers would be reduced and comput-

er centres pruned.

In January this year, Absa's mighty swallow of Bankorp in a R1,3-billion share swap took its asset base from R53-billion to more than R80-billion and set the scene for further staff reductions, branch closures and systems trimming.

Staff morale is said to be at an all-time low this week as staff axings are discussed.

One employee said it was widely rumoured that staff, said to number 44 000, would ultimately be reduced by 35 percent.

Three trade unions will fight for members' rights — the United Staff Association, the Financial Workers' Union (FIWA) and the Absa Workers' Unie.

The United Staff Association

general secretary, mr Frans Schimper, said it had negotiated very fair retrenchment packages.

"In most cases there is a two months' notice period and another six months' severance pay, so we're looking at eight months at full pay.

"Employees will also get compensation for loss of housing benefits and company car, and will receive full pension benefits — theirs plus Absa's."

Market sources say the retrenchment blows are likely to rain heaviest on Allied staff.

Of concern, though, is that Bankfin and Trustbank workers are not yet unionised and trade unions believe it may be too late to negotiate packages for these people. "It depends on how fast Absa moves."

Bankorp

SI Times (Bus)
lay-offs 5/4/92

BANKORP is to retrench employees as a result of its incorporation in Absa. (S9)

Absa says it is an extension of the rationalisation process that began in April last year.

Absa group executive for human resources Petrus Clasen says all alternatives to retrenchment will be considered before a final decision is taken. They include normal labour turnover, transfers, restrictions on recruitment, reductions in overtime, retraining, and the use of more temporary employees.

Layoff figures denied by Absa

SHARON WOOD (59)
71492

ABSA management had not put a figure on the number of employees who would be retrenched from the group during the next year, but reports of a 35% reduction in the staff complement were totally unfounded, group communications manager Jan Snyman said yesterday.

A Sunday newspaper reported that Absa was slashing its staff by 4 000 workers, a figure which could rise to 6 000 by mid-year, and its 44 000 staff would ultimately be reduced by 35%.

Snyman said the rationalisation process, which began when Allied, United and Volkskas merged to form Absa last year, would continue during the next financial year but retrenchments would not be nearly as high as reported. He also strongly denied the statement that retrenchments would be heaviest in Allied Bank.

The staff complement at Absa was 44 000; 26 000 from Absa and 18 000 from Bankorp. Bankorp had undergone a rationalisation process prior to its merger with Absa, he said.

A statement issued by the group at the weekend said Absa was conscious of the adverse economic climate facing the country.

Human resources director Petrus Claasen said all practical alternatives to the retrenchments would be pursued, including natural labour turnover, transfers to other areas in the group, restrictions on recruitment, overtime reductions, employee retraining and early retirement.

Job losses gain for union

B10 am 10/4/92

DIRK HARTFORD

WHITE collar workers in the financial services industry, exposed to mass retrenchments for the first time, were only now becoming aware of their rights and the benefits of union membership, said Financial Institutions Workers Union (Fiwu) general secretary Dallis Hall.

He was responding to recent retrenchments at Absa and Perm.

Neither the 11 500-strong union nor Absa would be drawn on details of retrenchment packages. Both said packages were often individually tailored.

The minimum standard package includes three months' salary, including notice pay, and the right to retain all car, pension, medical and housing benefits during this period.

In addition, some companies pay two weeks' salary for every year of service, up to a maximum seven months' pay.

Other benefits would also be retained in this period.

Pension payouts usually include the employer's contribution plus interest.

Employees in financial institutions usually have subsidised housing loans or spe-

cial low interest loans between 2,5% and 7,5%. These revert to the commercial rate once the terms of the retrenchment package expire.

Although there have been retrenchments — neither the union nor Absa would say how many — jobs are also being cut through natural attrition and early retirement packages.

Companies tend to evaluate performance levels when retrenching, and apply last in, first out criteria.

The union said the biggest problem with retrenchment was employee trauma. "Fiwu is concerned about the manner in which line managers are handling employees in this emotional exercise," Hall said. The union has requested employee assistance and counselling by outside agencies.

Employers should try to avoid retrenchment at all cost. "The economic climate has pressurised employers to reduce costs through retrenchments, but employers have a social responsibility," Hall said.

4857,8

relocating...



Saccawu demands a joint employers' forum in June

THE SA Commercial, Catering and Allied Workers' Union (Saccawu) has threatened to occupy major stores, hotels and banks if all the major service sector employers do not come to a joint meeting in June to discuss the 96 000-member union's demands.

Saccawu will also then demand the nationalisation of the service industry.

This emerged from Saccawu's national bargaining conference held at the weekend.

The union said it would present all retail, catering and financial services employers with demands for a national industry forum, a national provident fund and training board.

Saccawu also rejected job flexibility, employing casual workers and subcontracting, and demanded

DIRK HARTFORD

a moratorium on retrenchments. It would oppose any wage freeze and fight for a living wage.

If employers did not meet these demands in June, Saccawu would declare disputes, apply for conciliation boards and conduct strike ballots.

The strike ballot would be for national strike action, including occupation of stores, hotels or banks.

When Saccawu last called all employers to a joint meeting in March — to discuss a national provident fund — the only major employers to turn up were Metro and Karos Hotels.

According to Saccawu, Pick 'n Pay and Metro have already indicated they would attend.

If current offers on the table in the retail and catering sector are anything to go by, the union seems headed for a major showdown with employers.

Checkers, which is losing several million rands each month, has proposed a 10% wage cut, and provided the

union with a long list of stores it wants to close altogether.

And Southern Suns and OK Bazaars are offering 7% and 5% respectively, both to be implemented later than usual due to depressed conditions.

In retail, where minimum wages range from R500 to R1 250 a month, there are large disparities between groups.

Pick 'n Pay, for example, has offered a 13% increase and it, along with Edgars and Wooltru, is among the sector's top performers.

Retail employers are reluctant to join a national forum for the service industry because of the scope of industry. Saccawu has organised everything from supermarkets to hairdressers.

In the financial sector, where Saccawu's membership is minute, the 22 000-strong SA Society of Bank Officials recently had to abandon a strike at First National Bank after its members voted against it. And the Perm and Absa are retrenching staff.

Absa heads still rolling

STimes (BUS) 19/4/92

By ZILLA EFRAT

(59)

MORE than 1 350 employees have been axed since the formation of Absa last year. At least another 292 jobs, including those at Bankorp, are due to go.

So says Absa group executive, human resources, Petrus Claassen, who dismisses reports that about 4 000 jobs will be lost by March next year.

Dr Claassen declines to say how many people will lose their jobs because it will take until June to decide on the number.

He says retrenchments are being made to eliminate inefficiencies and duplication as Absa companies, including the recently acquired Bankorp group, are brought together.

The movement of people around the group, aimed at better space use, will also have implications on the property side.

Absa general manager, property, Hannes van der Merwe confirms that some of the group's leases are likely to be ended as employees move to the group's buildings. In the longer term, some Absa buildings could be sold.

Societies

Reports of numerous retrenchments at Bankorp subsidiaries Senbank and TrustBank continued to filter through this week.

Staff members say the retrenchments started at the upper levels and have started moving downwards.

Dr Claassen says the average retrenchment package is for four months' pay. The group's replacement centre is trying to find positions for those who have been retrenched. This, however, will become more difficult if retrenchment numbers grow.

South African Society of Bank Officials (Sasbo) general secretary Ben Smith says members believe that business decisions are being taken with scant concern for the human cost.

Mr Smith says the situation results from a "notoriously autocratic" approach to industrial relations that has characterised companies that make up the Absa group.

The former building societies that now have leading roles in Absa were notoriously anti-union, he says.

Officials of other unions representing bank workers could not be reached for comment.

Bank aims to train its own management

STAR 23/4/92

59

Although it is a black-owned bank, all the top positions at Future Bank are held by whites.

Managing director Neville Watchurst explains: "There are a number of reasons, and most important is the fact that there is little banking experience in the black community.

"Few black people have managed to achieve senior status in conventional banks."

A management agreement exists between Future Bank and First National whereby the bank will be managed for a period of 12 years.

Of the bank's 57 employees, the top 16 have been seconded from First National subsidiary Wesbank.

"We have two objectives: to find the right people and train them to be skilled bankers who will be able to take over the top management positions, including mine.

"One of these days we will not only have a black-owned but a black-managed bank as well," Mr Watchurst says.

The bank's other 41 employees in Johannesburg, Pretoria and Bloemfontein are mostly black.

"They were recruited from all walks of life. Some had banking experience, but most

had zero banking experience.

"We did not restrict ourselves to people with formal banking experience. Instead we chose people we thought had the potential and could be trained."

"It is difficult to find the kind of person we are looking for because it will take a certain kind of person to succeed here.

"The big banks have large client bases and established procedures. The environment in the big banks is very comfortable and the people will behave accordingly.

"We need exciting people who will go out and market our products."

Nobody at the bank will be talking about equal opportunities. Mr Watchurst says: "To me it is an old, somewhat trite phrase.

"It also smacks of tokenism. If it is fashionable to have a lady, you go and get one, and the same if it is fashionable to have a black person.

"What we are saying is that no matter whether you are black, white, male or female, the opportunities for advancement will be exactly the same.

"We are a brand new company and everyone has started at the same time. It is up to the staff to prove themselves."

New agency clinches account

STAR 23/4/92

Seven advertising agencies were allowed to pitch for the Future Bank account, and it was newly established all-black agency Herdbuoys' approach that impressed the most.

"We did not just choose them because they were black. They truly understood the bank's mission more clearly than the other competitors," general manager, marketing, Phillip van der Heever says.

The modest advertising budget will restrict to some extent the ability to go over the top in terms of TV advertising.

The strategy is to concentrate on Radio and print. Slots have already been flighted on Radio Metro, Bop and 702 and the intention is to attract "the influentials" in the hope that benefits will cascade down to the broader public.

Herdbuoys MD Peter Vundla believes his company clinched the account because of the creative work they gave the bank.

"In addition our strategic positioning of the bank came from a deep and clear understanding of the bank's main markets."

"We understood the frustrations black people encounter at the major banks and our research backed our views, hence the decision on the slogan: 'The bank with a new attitude.'"

S
S
The
the
soft
ket.
T
nifi
peti
par
F
er,
tion
the
sys
● A
● A
fix
cou
I
me
cal
wh
● A
tem
and
nec
● A
A
tem
and
A
syst
dat
syst
T
de
fea
cou

Marketing: Lindiwe's own medicine

Marketing manager Lindiwe Kubheka, the most senior black person at Future Bank apart from the board members, always wanted to become a doctor.

Because she was good at the sciences, her teachers encouraged her to become a doctor, she says.

"In those days in the black community you were either a doctor, a lawyer, a teacher or a nurse. There were no other role models. Most people had a limited knowledge of available career paths. If you were good at the sciences, choosing a career

was simple: you became a doctor. It affected me, because I began to fancy myself as a doctor."

After matriculating, however, she went to work for five years. She worked for a few companies in accounting positions, before deciding, in 1983, to go to Vista University to study for a bachelor of commerce degree.

After finishing her degree she spent five years at the Perm as a marketing research executive.

In May last year she was employed by a tupperware company as a marketing analyst.

She joined the Future Bank last month.

Explaining her decision to join the bank as marketing manager, she says: "Marketing is a comfort zone for me, with all my previous experience in the field."

"The position was also attractive because it gave me a wider scope. I am involved in all spheres of the marketing function — research, product development, advertising, public relations and so on."

How will she cope in the banking world? "The secret is that I have both brown and blue eyes," she jokes.

"More seriously, though, with my training and work experience in marketing and banking I understand the formal First World environment."

"Coming from a disadvantaged community, I also understand this world's banking needs. I am able to see potential gaps in less formal markets and turn them into good business for the bank."

On her experience at the bank so far, she says: "It is a brand new company. We are still learning to crawl together."

Lindiwe does not believe in talking about "black business" and "white business."

"We are a bank for all South Africans. If we were to be a bank for black people, we would land ourselves in problems."

"In SA we have reached a point where markets are segmented not by colour but socioeconomic conditions."

Lindiwe says she still has a lot to learn. She would eventually like to see herself and other black people in the bank advance to more senior positions.

Bank aims to train its own management

Although it is a black-owned bank, all the top positions at Future Bank are held by whites.

Managing director Neville Watchurst explains: "There are a number of reasons, and most important is the fact that there is little banking experience in the black community."

"Few black people have managed to achieve senior status in conventional banks."

A management agreement exists between Future Bank and First National whereby the bank will be managed for a period of 12 years.

Of the bank's 57 employees, the top 16 have been seconded from First National subsidiary Wesbank.

"We have two objectives to find the right people and train them to be skilled bankers who will be able to take over the top management positions, including mine."

"One of these days we will not only have a black-owned but a black-managed bank as well," Mr. Watchurst says.

The bank's other 41 employees in Johannesburg, Pretoria and Bloemfontein are mostly black.

"They were recruited from all walks of life. Some had banking experience, but most

had zero banking experience. "We did not restrict ourselves to people with formal banking experience. Instead we chose people we thought had the potential and could be trained."

"It is difficult to find the kind of person we are looking for because it will take a certain kind of person to succeed here."

"The big banks have large client bases and established procedures. The environment in the big banks is very comfortable and the people will behave accordingly."

"We need exciting people who will go out and market our products."

Nobody at the bank will be talking about equal opportunities. Mr. Watchurst says: "To me it is an old, somewhat trite phrase."

"It also smacks of tokenism. If it is fashionable to have a lady, you go and get one, and the same if it is fashionable to have a black person."

"What we are saying is that no matter whether you are black, white, male or female, the opportunities for advancement will be exactly the same."

"We are a brand new company and everyone has started at the same time. It is up to the staff to prove themselves."

New agency clinches account

Seven advertising agencies were allowed to pitch for the Future Bank account, and it was newly established all-black agency Herdhuys' approach that impressed the most.

"We did not just choose them because they were black. They truly understood the bank's mission more clearly than the other competitors," general manager, marketing, Phillip van der Heever says.

The modest advertising budget will restrict to some extent the ability to go over the top in terms of TV advertising.

The strategy is to concentrate on Radio and print. Slots have already been flighted on Radio Metro, Pop and 702 and the intention is to attract "the influencers" in the hope that benefits will cascade down to the broader public.

Herdhuys MD Peter Vundla believes his company clinched the account because of the creative work they gave the bank.

"In addition our strategic positioning of the bank came from a deep and clear understanding of the bank's main markets."

"We understood the frustrations black people encounter at the major banks and our research backed our views, hence the decision on the slogan: 'The bank with a new attitude.'"

State-of-the-art system for bank

The Future Bank has acquired the latest and most appropriate software available on the market.

This will give the bank a significant advantage over competitors in the important early part of its life.

Future Bank general manager, administration and collections, James de Smidt says their IBM Risc 6000 computer system has:

- A general ledger system.
- An investment system for fixed deposit and other accounts.

It will be able to produce immediate systems with interest calculations for clients anywhere in the country.

- An instalment debtors system that will monitor all loans and produce, on demand, all necessary statements.
- A new business system.

A unique feature of the system is that it is fully integrated and can operate separately. Alterations to the investment system will be immediately updated on the general ledger system.

The system also has what Mr. de Smidt believes is another feature that is unique in the country.

"For the first time in South Africa it will be possible to integrate such an operating system with the latest imaging technology."

"If someone has a fax machine he will be able to do business with us from any part of the country."

"A dealer, for example, will merely fax an application into our system."

"A copy can then be placed in system using the imaging technology and the operating systems are updated at the same time," he says.

Mr. de Smidt says that while the technology is widely available in the country, separate imaging systems exist along separate operating systems.

"We have managed to combine the two," he says.

Mr. de Smidt says the technology will increase the bank's ability to provide a superior service.

"It will also enhance our ability to generate new business. As long as a client has a fax machine he will be able to deal with us from anywhere in the country."

"The technology is also very user friendly, cost effective and flexible in that it is able to adapt to user requirements at very short notice."



Fast rising . . . Marketing manager Lindiwe Kubheka, the most senior black member of staff — apart from the board members.

Absa will finalise staffing needs by June

By Roy Cokayne

S9

STAR 24/4/92

Absa (Amalgamated Banks of South Africa) has retrenched 1 300 employees since the giant financial institution was formed but a final retrenchment figure has not yet been determined.

Dr Petrus Claassen, Absa group executive (human resources), admitted the group — formed from the merger last year of the United, Allied, Volkskas and Sage Financial Services, with another merger with B&B Corp. being finalised this year — was top heavy.

But he described newspaper

reports of 4 000 employees ultimately being retrenched as "pure speculation".

He said the rationalisation programme was not focused only on TrustBank but on all divisions within the group.

It was not focused on senior employees alone, but was being conducted from the top down, with senior managers the first to be retrenched.

A study of all the divisions, function by function, was being conducted to determine staff requirements.

Because three individual groups had been brought togeth-

er, it could be expected that Absa would be top heavy and that there would be duplication.

Absa's middle management was "a little over developed" and it would also be thinned out.

The main part of the study of the group's staff requirements would be completed by the end of June and the rationalisation would be completed within the following six to 12 months.

Absa had a well developed retrenchment policy, cleared by all the unions involved.

Where possible, employees were put on early retirement.

On hearing of their retrenchment employees were allowed to go home. This saved them any embarrassment in facing their colleagues, and protected the morale of the rest of the group.

Dr Claassen said of the 1 300 people retrenched since the formation of Absa, only one retrenchment case had gone to the Industrial Court.

Healthy office environments crucial to costs and productivity

South African companies must take a strategic approach to environmental management in the workplace as part of the country's international economic rehabilitation.

Doing so could save them up to 40 percent on office overheads, as well as enhancing productivity and gaining a competitive edge in terms of service and cost of sales.

So says Ray Farrenkothien, MD of CentreCore Office Environments, a United States service company which helps companies raise the quality of administrative environments.

It offers products that optimise the use of office space and improve air quality, and which has set up operations in Cape Town.

Businessmen here are used to



Compiled and written by Frank Jeans and Meg Wilson

regulations governing conditions on the factory floor but are not as familiar with the extent to which white collar working conditions have become a management concern worldwide.

"But Sick Building Syndrome (SBS) and its consequences are the corporate issues of the '90s — so much so that a recent European Community directive

sets out minimum health and safety standards for workers using computer monitors."

It is widely known that eye irritation, respiratory problems, ear, nose and throat infections can all be traced to poor quality of office environment.

The dangers of passive smoking have also been recognised.

However, there are other problems less well known.

The energy efficiency of air conditioning is undoubted, but standard recirculation systems may aggravate health problems.

Chemicals used in the manufacture and cleaning of carpets and furniture, dust and pollen, germs and viruses are all efficiently spread to the entire workforce.

In addition, productivity is

often reduced by the disturbance of artificial lighting, radiation from copiers and monitors, noise and other distractions.

However, says George Mitchell, president of CentreCore in the US, managements in South Africa are beginning to perceive the limitations of current arrangements, especially in high throughput areas such as customer services, accounting departments and telesales.

"The typical office layout wastes much expensive space and impedes rather than enhances teamwork. Modern techniques are also showing us the pitfalls of badly managed indoor air environments.

One product already attracting much attention in South Africa is Airflow 2000, an air conditioning system in which

separate units at individual work stations provide "an umbrella of clean air" for each worker.

On the positive side, South Africa is entering the field of office environment management fairly late, and local managers can choose the most advanced solutions without having to go through a costly process of trial and error.

Mr Mitchell says his company's clients — which include Total Oil, Satchi & Satchi, Hewlett Packard and the US Defence Force — typically experience saving of up to 40 percent on office space.

"Our mission in South Africa is to alert business to the administrative pressures of the '90s and offer workable, measurable solutions."

Many at Nedcor face axing

SIGNIFICANT structural changes within the Nedcor Group could see more than 100 employees facing the axe, industry sources said yesterday. *Blw ay*

One source at the bank said the figure could be as high as 400. *22/5/92*

Nedcor CE Chris Liebenberg said last night the 400 figure was "totally inaccurate", but would not commit himself to a number.

However, he said it was inevitable that certain positions would be lost in any restructuring but, in line with the group's policy, "superior performing staff" would be reallocated within the wider group.

Liebenberg said the Nedcor group, which employed

59
TIM MARSLAND

about 18 000 people, had over the past few years reduced staff through natural attrition.

At Nedcor subsidiary Finansbank 35 jobs are on the line. Internal services senior GM Tony Laubscher said attempts were being made to place the 35 in other divisions, but staff who lost their jobs would get a minimum of three months pay.

In the Nedcor Bank human resources division, 70 staff members out of a total of 340 may face the axe. Human resources executive GM Philip Bacchioni said there were no plans to retrench staff, and attempts were being made to place staff in the group.

Nedcor Bank divisional director Mike Leeming said fewer people were needed in the human resources department following the

Perm-Nedbank link-up.

Liebenberg said it was a worldwide phenomenon that banks were trimming operations. SA banks had to keep up with global trends to remain competitive.

Meanwhile, an Absa spokesman said the banking group's rationalisation was progressing according to plan. The group's objective was to give people certainty regarding their positions as soon as possible.

Meredith Jensen reports that the recent incorporation of Bankorp into Absa has prompted many former Bankorp employees to join the Financial Institutions Workers' Union (Fiwu).

The union said yesterday since April 1 nearly 600 workers who feared they might be among the 4 000 Absa/Bankorp employees scheduled for retrenchment this year have become union members.

Banking shake-up as job-cutting starts

(59)

ARG 26/5/92

Business Staff

BANK group Absa is concerned at the way its rationalisation programme is being implemented by some line managers and at the despondency of staff as widespread job-cutting gets under way.

Starting this week, head office personnel officials will visit group offices countrywide, telling staff and managers about the programme and listening to their woes.

Complaints are not inconsiderable — and group executives concede some are not without justification.

Absa (Amalgamated Banks of SA), originally an amalgam of United, Volkskas, Sage Financial Services and Allied, became far and away South Africa's biggest agglomeration of banks early this year in a R1 billion-plus share swop to acquire ailing Bankorp — which comprises TrustBank, Senbank and Bankfin.

Its assets topped R80 billion and staff numbers 45 000.

It is an open secret that South Africa is "over-banked" and Absa bosses conceded numbers would have to come down. Attrition was ruled out as the economy continued to decline and margins came under increased pressure.

A big restructuring pro-

gramme began and surplus numbers came up for the chop. But officials were coy when figures were mentioned.

Even as reports speculating 4 000 would go were being roundly denied, a number of 6 000 was bandied about, with estimates putting the final workforce at little more than half its original level.

Explaining the recent placing of 44 Durban staff members of the Bankfin motor finance division on the "surplus list" — Absa's method of retrenching — group personnel executive Neels Steenkamp said banks worldwide were overstaffed.

Some 20 000 were to be axed following the recent merger of Lloyd's and Midland banks in Britain, he said, while closer to home, Nedcor admitted this week it was trimming numbers.

"About 65 percent of the cost structure of a bank is people. With the economy declining and margins squeezed, something had to give," said Mr Steenkamp.

All South African banks had been cutting overheads through attrition for some time. Absa's were necessary for the continued survival of its constituent parts, he maintained, and had attracted attention only because they were by retrenchment.

"Because of the poor economic climate and the lack of vacancies anywhere, staff turnover is abnormally low and we cannot wait for time to take care of excess numbers.

"Obviously, because of the uncertainty and the harm retrenchments cause to morale, we want to move as quickly as possible," said Mr Steenkamp.

■ Nedcor Bank has embarked on an "integrated growth strategy" to improve efficiency and reduce costs, promising retrenchments would only be used as a last resort.

Nedcor CEO Richard Laubscher said in Johannesburg yesterday the group's new organisational structure was based on an analysis of the market serviced by financial institutions.

"We then segmented it (the market) very carefully and set out to align our businesses to match those segmentations," he said.

The restructuring process was almost complete and all duplication would be eliminated, Mr Laubscher said.

Elaborating on the details of the restructuring, he said marketing, human resources, processing and credit functions had been integrated across Nedbank and the Perm.

Nedcor trims 400 jobs in rationalisation

NEDCOR Bank had reduced its staff complement by about 400 during its restructuring to date — mainly through natural attrition, CEO Richard Laubscher said yesterday. Further cuts would only be introduced as a last resort, he added.

Speaking at a news conference Laubscher said natural attrition would handle the shrinkage in staff numbers. "But obviously low productivity workers will have to go," he said. "There was no final staff target number and the bank was prepared to increase staff in areas where there was a return.

Restructuring had involved a name change from Nedperm to Nedcor Bank and a separation of banking interests into individual business units.

Nedcor Bank's business units would consist of Nedbank's corporate, international, commercial and personal banking divisions, Nedfin Bank and the Perm.

Laubscher said the group would concentrate on niche markets through attitudinal, rather than income, segmentation.

Nedcor was trimming the infrastructural side of the Perm and would in future cater for risk-

averse clients who wanted off-the-shelf products, safety and security.

There were no plans to reduce any part of the Perm's advances book and hopefully the Perm book would grow, he said.

Nedcor Bank is carrying out the rationalisation in preparation for stiffer competition as foreign banks move into SA, Laubscher explained.

In a telephone interview after the press conference, he said: "It would be wrong not to anticipate a lot more competition. "From the country's point of

view we should welcome this. From the bank's point of view, we are playing on our own ground and it is our job to make sure that we are competitive.

"I would like to believe that we can create cost-effective solutions and new bank products."

But, he said, the bank's new integrated growth strategy would involve transferring people between Nedbank and the Perm and integrating marketing, human resources, processing and credit functions.

"We're remarkshalling our re-

sources in these key areas and expect significant cost and effectiveness benefits to accrue.

"In addition the best talent will thus benefit the whole of Nedcor Bank, which is consistent with our aim of becoming the employer of first choice across all demographic boundaries."

"We've re-engineered our organisation and put more hitting power where our actual businesses meet the public. At the same time, we are in the process of eliminating all duplication." — Business Editor and Own Correspondent

59 MAY 26/5/92

Nedcor Bank's staff reduced by 400

NEDCOR Bank had reduced its staff complement by about 400 during its restructuring to date — mainly through natural attrition, MD Richard Laubscher said yesterday. Further cuts would only be introduced as a last resort, he added.

Speaking at a news conference Laubscher said natural attrition would handle the shrinkage in staff numbers.

"But obviously low productivity workers will have to go," he said.

There was no final staff target number and the bank was prepared to increase staff in areas where there was a return.

Restructuring had involved a name change from Nedperm to Nedcor Bank and a separation of banking interests into indi-

SHARON WOOD

vidual business units.

Nedcor Bank's business units would consist of Nedbank's corporate, international, commercial and personal banking divisions, Nedfin Bank and the Perm.

Laubscher said the group would concentrate on niche markets through attitudinal, rather than income, segmentation.

Nedcor was trimming the infrastructural side of the Perm and would in future cater for risk-averse clients who wanted off-the-shelf products, safety and security.

There were no plans to reduce any part of the Perm's advances book and hopefully the Perm book would grow, he said.

26/5/92
B10 aw

(59)

Sturdy earnings from Absa but 849 jobs axed

(59)

CAPE TOWN
21/5/92

From SHARON WOOD

JOHANNESBURG. — In its first full financial year, banking conglomerate Absa showed a 15,2% rise in earnings but announced it had retrenched 849 staff members since April 1.

The group managed to exceed its projected savings target of R85m, with net savings of R98m during 1992 but had debt provisions leapt 157% to R450,6m from R175,4m.

MD Piet Badenhorst said manpower cost savings had been enormous adding staff numbers would be reduced "meaningfully" from the last financial year's 43 714, which included Bankorp staff.

Staff rationalisation would be completed in six months and technology rationalisation within 15 months, he said.

Earnings rose in line with market expectations to 107,6c a share during 1992 from 93,4c previously. The total dividend rose 9,7% to 39,5c a share from 36c.

Badenhorst said the group was aware that it would lose market share to its competitors during

the rationalisation process. "But we want to reduce our exposure to the corporate market in areas where we have been over-exposed," he said.

Attributable income jumped by 153% to R491m but this was not strictly comparable as it included only the preceding six months' results of Allied and Volkskas and three months of Sage interests.

Total ABSA assets increased by 8,5% to R56,2bn from R51,8bn. Advances rose by 10,5% to R42,1bn from R38,2bn. With Bankorp included from March 31, group assets are R84,4bn and advances are R64,7bn.

Return on average assets fell to 0,95% during 1992 from 1,01%. "This is not the kind of return we are striving for, we want it to be over one percent," Badenhorst said. ABSA chairman Herc Hefer expected no significant recovery from the recession. "Demand for credit is likely to remain sluggish and the high level of default amongst borrowers will continue," he said.

● Meanwhile, Standard Bank has extended its international links by acquiring British mer-

chant bank Brown Shipley Holdings for £10m (R51,4m), it announced yesterday.

Brown Shipley operates on Jersey and the Isle of Man, two major international financial service centres, and has high volumes of funds under administration and representation from most leading global banking and investment institutions, a Standard Bank statement says.

The deal is subject to the agreement of UK authorities.

The acquisition will allow Standard Bank involvement in all areas of offshore asset management including banking and global custody, fiduciary services, investment management and stockbroking.

The deal will have negligible effects on profit and net assets in the short term, but major long-term benefits are expected.

All of SA's big four banks have interests in the UK but Standard and FNB are still waiting to receive banking licences from the Bank of England.

Nedcor Bank and Absa received banking licences prior to the debt standstill and operate fully functioning branches in London.

Absa staff cuts aid earnings growth

B/Daw 27/5/92

SHARON WOOD

IN ITS first full financial year, banking conglomerate Absa showed a 15,2% rise in earnings but announced it had retrenched 849 staff members since April 1.

The group managed to exceed its projected savings target of R85m, with net savings of R98m during 1992.

But bad debt provisions leapt 157% to R450,6m from R175,4m.

MD Piet Badenhorst said manpower cost savings had been enormous, adding that staff would be reduced "meaningfully" from the last financial year's 43 714, which included Bankorp staff.

Staff rationalisation would be completed in six months and technology rationalisation within 15 months, he said.

Earnings rose in line with market expectations to 107,6c a share during 1992 from 93,4c previously. The total dividend rose 9,7% to 39,5c a share from 36c.

Badenhorst said the group was aware that it would lose market share to its competitors during the rationalisation process. "But we want to reduce our exposure to the corporate market in areas where we have been overexposed," he said.

Attributable income jumped 153% to R491m, but this was not strictly comparable as it included only the preceding six months's results of Allied and Volkskas,

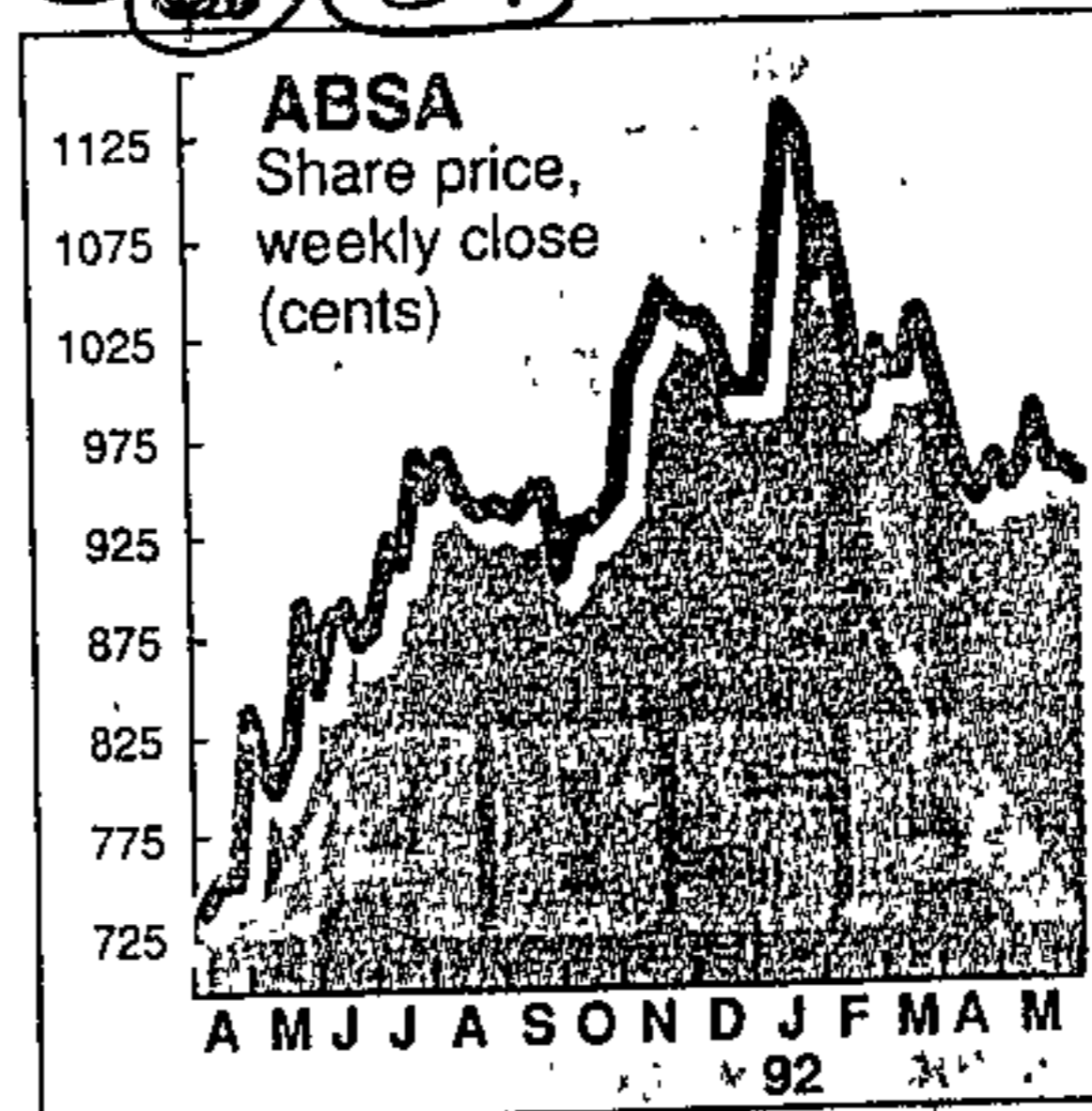

Graphics RUBY-GAY MARTIN Source: I-NET

and three months of Sage interests.

Total Absa assets increased 8,5% to R56,2bn from R51,8bn. Advances rose by 10,5% to R42,1bn from R38,2bn. With Bankorp included from March 31, group assets were R84,4bn and advances R64,7bn.

Return on average assets fell to 0,95% during 1992 from 1,01%. "This is not the kind of return we are striving for, we want it to be over one percent," Badenhorst said. Absa chairman Herc Hefer expected no significant recovery from the recession. "Demand for credit is likely to remain sluggish and the high level of default amongst borrowers will continue," he said.

8/Day 29/5/92
**10% of staff
weak ^(S) bank**

TIM MARSLAND

NEDCOR Bank believes 10% of its staff members are underperforming, and the banking group plans to whittle this figure down to zero by September 30.

Confidential documents show the company believes 20% of employees are "highly exceptional top performers" and that Nedcor "will only have superior staff members in our employ by September 20 1992".

According to the documents, Nedcor has embarked on a programme to identify workers who, it believes, are not up to standard. It will then attempt to retrain them.

Executive GM, human resources Nedcor Bank, Philip Bacchioni said these workers — about 500 — would not necessarily be retrenched. They would first be given the opportunity to improve themselves through a personal improvement programme (PIP) and could be offered a job at a lower grade.

As a last resort, they would be retrenched. However, 95% of staff put on PIP came up to standard. Overall, the Nedcor group had cut its staff complement by 400 since October 1, mostly through attrition. He said 35 workers were laid off. The cost of the programme would be minimal.

Staff turnover in the Nedcor group was about 10% of the total 17 000, so numbers could be cut by not replacing staff. "We will make sure we look after performing employees," Bacchioni said.

Saambou Bank retrenches 300

SHARON WOOD

SAAMBOU Bank has retrenched 300 people after restructuring its head office and branch office network.

Group MD Johan Myburgh said in a statement yesterday the approximately 300 people involved were individually consulted. Personnel affected by the restructuring had received the necessary aid, guidance and severance compensation.

"Certain areas where significant target market shifts have taken place recently have necessitated the restructuring process," he said.

The restructuring had been completed and the final touches were now being given to the new branch network and streamlined structure. The new structure would be fully operational on July 1.

"The restructuring of Saambou Bank's structures was necessary to improve its competitiveness in the market, as well as to further extend its aim to be a low-cost supplier of banking services to the salary earner and pensioner."

Several senior Absa dealers have also

been left without jobs after rationalisation of the bank's three dealing rooms.

An Absa spokesman confirmed that there had been a "surplus" of dealing room staff as a result of the rationalisation process, but would not give the number of dealers retrenched.

An Eskom spokesman had received calls from applicants but could give no further details. When asked whether any of the applicants had been given jobs at Eskom he said: "No, there is no space, which is unfortunate because there are some good people."

A Standard Bank spokesman said the bank's dealing room staff turnover was virtually zero. This was because the bank usually did not employ outside people. FNB senior dealer Ken Russell said he had seen a number of CVs from retrenched Absa staff, but not as many as were expected.

(59)

Plan to train black bankers in New York

By Andrew Krumm
9/16/92

A GROUP of US banks has agreed to sponsor a six-month financial and banking management development programme in New York for six promising black employees of SA banks.

Joyce Brown, of New York's City University, who will administer the project, said its purpose was to enhance the professional capabilities of black South Africans who had the capacity to play significant leadership roles in their companies.

Brown said the sponsors — Chase Manhattan, the Chemical Bank, JP Morgan and Co, the First Boston Corp and CitiBank — had been approached by New York mayor David Dinkins to make an investment in the people of SA.

Southern Life employee benefits and marketing regional manager Richard Molewa, one of six candidates selected for the project, said he had positive expectations as the scheme meant exposure to a different world.

He said the programme was run on a mentor system with each candidate employed in an area of expertise of his own choice.

FNB Parktown branch manager Harvey Khuzwayo said the project was a "lifetime opportunity". He said he would concentrate on corporate banking, credit and risk management.

"Although the programme will keep me away from my wife and two children for six months, it is worthwhile."

Both Khuzwayo and Molewa rejected the idea that the project was tokenism on the part of US banks.

The other candidates are from Standard Bank, the Perm, Premier Foods and Nedcor.

B/Denny 10/6/92

A vital role played in creating employment

B/Denny

10/6/92

59

53

53

53

SAPOA provides employment for some 4 million people in the formal economy — about 75% of those employed outside agriculture — if employment in the services, retail, industrial and construction sectors are taken into account.

Sapoa president Derek Stuart-Findlay says Sapoa members therefore play a vital role in the generation of employment and international evidence has shown that only the cities can generate work on the scale required to meet the huge population rises in the developing countries.

"Everybody is looking for that first job that will enable them and their families to start climbing the ladder of economic fortune. The activities of our members play a crucial role in this process," he says.

The commercial property industry represents about 20% of SA's total gross domestic fixed investment and consists of three major forms of investment — the office, retail and industrial markets.

The office market is occupied by the services sector of the economy. This

sector, which includes finance, trade, tourism, communication and government, represents 50% of gross domestic product (GDP).

"Locally, the services sector employs 1.5-million people. The office market houses this sector and I believe that our developers have acted responsibly during the last recessionary period in relation to similar conditions in many Western economies," he says.

Distribution

An outstanding characteristic of the local economy is its excellent distribution system. In many parts of SA, competition between retailers is as intense as anywhere in the Western world.

In metropolitan areas today there are about 16 regional centres each with a gross lettable area of more than 45 000m², 30 hypermarkets with an average area of 20 000m², more than 50 community centres averaging 17 500m² and hundreds of convenience and "high street" city and town centres.

"The challenge is now to provide appropriate facilities in the less affluent suburbs. The potential is mind boggling. We face a situation where black South Africans represent some 75% of our country's population.

"Although only about 57% of this group is urbanised, their spending power already represents 41% of the total," he says.

Some 760 000 people are employed in the local formal retailing sector and there is no doubt that the retailing industry will continue to be a major generator of employment, wealth creation and distribution.

Sapoa members participate in this process by funding and developing structures within which retailing activities take place.

Members also manage a great proportion of the properties used for manufacturing and warehousing. The strength of this sector has been one of the surprises of the last few years of the recession, he says.

"With indications of renewed stability in our capital account and with the



TOILET

Quality

Rramfontain

Sectional title needs to change with the times

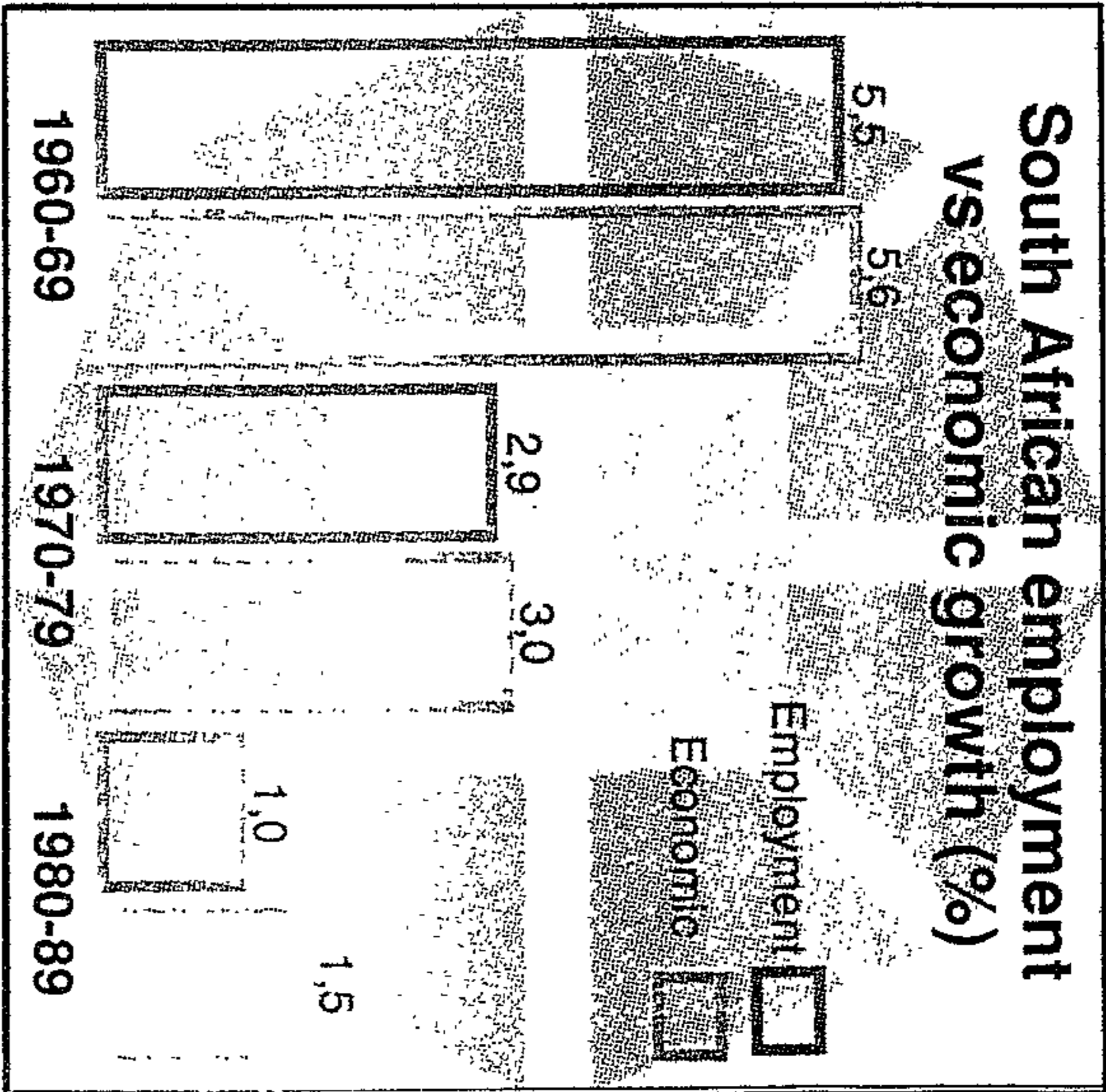

Graphics: RUBY-GAY MARTIN Source: OLD MUTUAL

rebuilding of gold and foreign exchange reserves, interest rates should continue to decline slowly.

"As a result, we are likely to see increased investment in manufacturing. Given a reasonable investment scenario, offshore investors could start setting up new manufacturing plants," he says.

During the 1960s, local economic performance at an average of 5.5% a year compared favourably with the rest of the world. During the 1970s SA grew at only 3% a year compared with 3.5% for the developed countries and 5% for the developed world.

"The 1980s were disastrous for SA, which grew at only 1.5% a year while the rest of the world grew at 3% to 3.5% a year on average," he says.

Property education a major contribution

By Day 10/6/92

18 19 20 21 22 23 24 25 26 27 28 29 30 31

ONE of Sapo's major contributions to the property industry is its advancement of property education.

It has continually sourced the market for its needs and adapted and expanded its courses to cater for this. Five courses are offered at present, says executive director Brian Kirchmann.

"The best known of the courses is the property development programme, which is now in its 17th year.

"It has released more

than 1 000 participants into the industry," he says.

The programme is a joint venture between the University of Cape Town Graduate School of Business and Sapo, and is held in Cape Town over two weeks in July and August of each year.

It caters for 64 participants and covers the principles of finance, valuation and property law, negotiations, marketing and management.

Draws

Designed for executive management, the "live-in" course draws participants from all disciplines of the property industry.

The next bi-annual property executive programme will be run in September.

The course caters for about 40 participants, drawn mainly from senior executive positions.

Matters like the local political and economic climate and the international scenario are examined.

The course is designed to encourage group participation, Kirchmann says.

As a result of investigations by the industry among school leavers and the public, a three-year property course has been devised.

Starting in January 1993 and administered by Technikon RSA, the course intends to promote vocational training.

"This is the first time that a local Technikon is presenting formal tertiary education in real estate, and we hope that the course will eventually be developed so it can be presented by any university," he says.

A new basic property programme will be launched in October.

It will be an introduction to property, covering elementary economics, law, marketing, finance and a basic understanding of the industry.

The property introductory programme was run for the second time last month. It is designed to improve participants' basic knowledge of the many aspects of the industry.

Shopping centre management and development courses, planned for

August this year, will be handled by Chris Cloete from the University of Pretoria. Each course will be limited to 25 participants, will be three days in duration and an examination will be written at the end.

The shopping management centre course participants will have to carry out a spot analysis of a shopping centre.

Background research of the viability of development on a possible site will also be required.

It is planned that both courses will have to be passed before acceptance is granted for a proposed two-year course.

"One of our aims is to continue to identify the educational needs of both the industry and the general public and to find ways of catering for these.

"Our courses have been innovative, and we intend to go from strength to strength in this sphere," Kirchmann says.

RTNERS

T S

Development

Industry has had to adapt to radical technology change

By Day 10/6/92
BUILDING industry changes during the past 57 years have been revolutionary.

A gentleman's agreement is now defunct terminology and restrictive

hams says.
More university graduates have moved across to work with building firms in project management, and there is generally a higher level of professionalism in



Bara strikers dig in their heels



Sowetan 10/6/92

THE NATIONAL Education and Health Workers Union yesterday vowed to defy a court interdict and continue with their strike and pickets over wage grievances at Baragwanath Hospital.

A Nehawu spokesman yesterday said the union members from 10 other clinics in Soweto were expected to join the strike.

A Sowetan team which visited the hospital yester-

By **KENOSI MODISANE**

day found workers at the kitchen preparing food.

The workers, as well as those in the theatres and mortuary, are exempted from the strike.

Nurses and doctors have to fetch the food from the kitchen for distribution to patients.

"We are operating nor-

mally although the floors and other areas are not clean. Nurses fetch the food for patients in the wards," a chef said.

Some workers at the theatre were found performing their normal chores, though one said: "It is a bit slow since Monday. But we are all the same on duty and exempted from joining the picket."

Nehawu spokesman Mr Chicks Moletsane yester-

day accused the hospital authorities of unfairness and said: "They asked the TPA to apply for an interdict restraining us from picketing in the hospital instead of solving the problem."

Baragwanath officials yesterday locked doors leading to the administration block and security personnel barred reporters from entering.

An attempt to reach the

hospital spokesman for comment through the telephone also drew a blank.

It was yesterday reported that student nurses at the hospital held a meeting on Monday where a decision was taken to picket daily for an hour in sympathy with the striking workers.

"We are prepared to resume our duties as soon as the authorities respond to our demands," Moletsane said.

KENNISGEWING 517 VAN 1992**DEPARTEMENT VAN MANNEKRAG****WET OP ARBEIDSVERHOUDINGE, 1956****AANSOEK OM VERANDERING VAN DIE REGISTRASIEBESTEK VAN 'N VAKVERENIGING**

Ek, Gerhardus Coenraad Papenfus, Assistentnywerheidsregistrator, maak ingevolge artikel 4 (2) soos toegepas by artikel 7 (5) van die Wet op Arbeidsverhoudinge, 1956, hierby bekend dat 'n aansoek om die verandering van sy registrasiebestek ontvang is van die Financial Institutions Workers Union. Besonderhede van die aansoek word in onderstaande tabel verstrekk.

Enige geregistreerde vakvereniging wat teen die aansoek beswaar maak, word versoek om binne een maand na die datum van publikasie van hierdie kennisgewing sy beswaar skriftelik by my in te dien, p/a die Departement van Mannekrag, Mannekraggebou 123A, Schoemanstraat 215, Pretoria (posadres: Private Bag X117, Pretoria, 0001).

TABEL

Naam van vakvereniging: Financial Institutions Workers Union.

Datum waarop aansoek ingedien is: 28 April 1992.

Belange en gebied ten opsigte waarvan aansoek gedoen word: Alle persone in diens in die Finansiële Instellingsonderneming in die Republiek van Suid-Afrika.

Vir die doeleindes hiervan beteken—

“Finansiële Instellingsonderneming” die onderneming waarin werkgewers en hul werknemers met mekaar geassosieer is in 'n finansiële instelling met die doel om besigheid te dryf, en omvat dit sodanige bedrywighede indien onderneem deur 'n moedermaatskappy, geassosieerde maatskappy of filiaal van 'n finansiële instelling;

“finansiële instelling” —

Enige instelling geregistreer ingevolge die Wet op Deposisionemende Instellings, 1990 (Wet No. 94 van 1990);

'n bouvereniging geregistreer ingevolge die Wet op Onderlinge Bouverenigings, 1965 (Wet No. 24 van 1965);

'n versekeraar geregistreer ingevolge die Ver-sekeringswet, 1943 (Wet No. 27 van 1943);

'n Pensioenfondsorganisasie geregistreer ingevolge die Wet op Pensioenfondse, 1956 (Wet No. 24 van 1956);

'n onderlinge hulpvereniging geregistreer ingevolge die Wet op Onderlinge Hulpverenigings, 1956 (Wet No. 25 van 1956);

'n effekte-trustskema soos omskryf in die Wet op beheer van Effekte-trustskemas, 1981 (Wet No. 54 van 1981);

'n eksekuteurskamer of 'n trustmaatskappy of enige ander maatskappy wat beleggings maak of enige trusteeendom in veilige bewaring hou, beheer of administreer;

NOTICE 517 OF 1992**DEPARTMENT OF MANPOWER****LABOUR RELATIONS ACT, 1956****APPLICATION FOR VARIATION OF SCOPE OF REGISTRATION OF A TRADE UNION**

I, Gerhardus Coenraad Papenfus, Assistant Industrial Registrar, do hereby, in terms of section 4 (2) as applied by section 7 (5) of the Labour Relations Act, 1956, give notice that an application for the variation of its scope of registration has been received from the Financial Institutions Workers Union. Particulars of the application are reflected in the subjoined table.

Any registered trade union which objects to the application is invited to lodge its objection in writing with me, c/o the Department of Manpower, 123A Manpower Building, 215 Schoeman Street, Pretoria (postal address: Private Bag X117, Pretoria, 0001), within one month of the date of publication of this notice.

TABLE

Name of trade union: Financial Institutions Workers Union.

Date on which application was lodged: 28 April 1992.

Interests and area in respect of which application is made: All persons employed in the Financial Institutions Undertaking in the Republic of South Africa.

For the purposes hereof—

“Financial Institution Undertaking” means the undertaking in which employers and their employees are associated in a financial institution for the purpose of conducting business, and includes such activities if conducted by a parent company, associate company or subsidiary of a financial institution;

“financial institution” means—

any institution registered in terms of the Deposit-taking Institutions Act, 1990 (Act No. 94 of 1990);

a building society registered in terms of the Mutual Building Societies Act, 1965 (Act No. 24 of 1965);

an insurer registered in terms of the Insurance Act, 1943 (Act No. 27 of 1943);

a pension fund organisation registered in terms of the Pension Funds Act, 1956 (Act No. 24 of 1956);

a friendly society registered in terms of the Friendly Societies Act, 1956 (Act No. 25 of 1956);

a unit trust scheme as defined in the Unit Trusts Control Act, 1981 (Act No. 54 of 1981);

a board of executors or a trust company or any other company which makes investments or keeps in safe custody, controls or administers any trust property;

'n bestuurder wat ingevolge die Wet op Deelnemingsverbande, 1981 (Wet No. 55 van 1981), 'n skema beheer of administreer;

'n eiendomsagent geregistreer ingevolge die Wet op Eiendomsagente, 1976 (Wet No. 112 van 1976);

en omvat dit enige filiale of assosiate gestig of verkry waarin sodanige finansiële instelling 'n beherende aandeel of meerderheidsbelang het.

Posadres van applikant: Posbus 30917, Braamfontein, 2017.

Kantooradres van applikant: Jutstraat 101, Braamfontein.

Die aandag word gevestig op onderstaande vereistes van artikels 4 en 7 van die Wet:

- (a) Die mate waarin 'n beswaarmakende vakvereniging verteenwoordigend is, word ingevolge artikel 4 (4), soos toegepas by artikel 7 (5), bepaal volgens die feite soos hulle bestaan het op die datum waarop die aansoek ingedien is, en wat die lidmaatskap betref, word alleen lede wat ingevolge artikel 1 (2) van die Wet op voormelde datum volwaardige lede was, in aanmerking geneem.
- (b) Die prosedure voorgeskryf by artikel 4 (2) moet gevolg word in verband met 'n beswaar wat ingedien word.

G. C. PAPENFUS,

Assistentnywerheidsregistrateur.

(12 Junie 1992)

KENNISGEWING 520 VAN 1992

DEPARTEMENT VAN PLAASLIKE REGERING EN NASIONALE BEHUISING

RAAD VIR DIE KOÖRDINERING VAN PLAASLIKE OWERHEIDSAANGELEENTHEDE: AANWYSING VAN PERSONE OF INSTELLINGS VIR DOEL-EINDES VAN LIDMAATSKAP

Ek, Leon Wessels, maak hiermee vir algemene kennis bekend dat ek, kragtens die bevoegdheid my verleen by artikel 3 (3) (a) (ii) en 5 (iii) van die Wet op die Bevordering van Plaaslike Owerheidsaangeleenthede, 1983 (Wet 91 van 1983), mnr. S. Immelman aanstel as lid van die Raad vir die Koördinering van Plaaslike Owerheidsaangeleenthede en van die Raad se Aksiekomitee vir 'n tydperk van twee jaar, met ingang van 1 Januarie 1992.

L. WESSELS,

Minister van Plaaslike Regering en Nasionale Behuising.

a manager who, in terms of the Participation Bonds Act, 1981 (Act No. 55 of 1981), controls or administers a scheme;

an estate agency registered in terms of the Estate Agents Act, 1976 (Act No. 112 of 1976);

and includes any subsidiaries or associates established or acquired in which such financial institution has a controlling or majority interest.

Postal address of applicant: P.O. Box 30917, Braamfontein, 2017.

Office address of applicant: 101 Juta Street, Braamfontein.

Attention is drawn to the following requirements of sections 4 and 7 of the Act:

- (a) The representativeness of any trade union which objects to the application shall in terms of section 4 (4) as applied by section 7 (5) be determined on the facts as they existed at the date on which the application was lodged and, as far as membership is concerned, only members who were in good standing in terms of section 1 (2) of the Act as at the aforesaid date shall be taken into consideration.
- (b) The procedure laid down in section 4 (2) must be followed in connection with any objection lodged.

G. C. PAPENFUS,

Assistant Industrial Registrar.

(12 June 1992)

NOTICE 520 OF 1992

DEPARTMENT OF LOCAL GOVERNMENT AND NATIONAL HOUSING

COUNCIL FOR THE CO-ORDINATION OF LOCAL GOVERNMENT AFFAIRS: DESIGNATION OF PERSONS OR INSTITUTIONS FOR PURPOSES OF MEMBERSHIP

I, Leon Wessels, hereby notifies for general information that, in terms of the power vested in me by section 3 (3) (a) (ii) and 5 (iii) of the Promotion of Local Government Affairs Act, 1983 (Act 91 of 1983), I hereby appoint Mr S. Immelman as a member of the Council for the Co-ordination of Local Government Affairs and of the Council's Action Committee for a term of two years, with effect from 1 January 1992.

L. WESSELS,

Minister of Local Government and National Housing.

NEWS IN BRIEF

(S1) ~~SECRET~~ ~~SECRET~~
Seven to train in US

SEVEN black SA professionals left for New York yesterday on a six-month financial and banking management development programme, sponsored by Chase Manhattan, the Chemical Bank, J Morgan and Co, the First Boston Corp and Citibank.

S/pang 15/6/92

FM - 19/6/92 (S9)

SA HOUSING TRUST (S9)

De Ridder resigns FM 19/6/92

Another top official is leaving the SA Housing Trust. GM Johan de Ridder has resigned to further his career in property development. His imminent departure follows close on the resignation of marketing divisional head Johan Raubenheimer who left under a cloud following revelations in the *FM* that he had falsely claimed to have a doctorate from

the University of Pretoria's Business School (*Current Affairs* June 15).

Housing Trust MD Wallie Conradie stresses that there is no cloud over De Ridder: "In fact it is with regret that we accept his resignation. He's made a big contribution to the trust since joining us four years ago from the Development Bank."

De Ridder points out that he submitted his resignation at the beginning of May and will leave the trust at the end of this month. "However, I expect to continue to be associated with the organisation for some time. There is no question of friction, disillusion or bad blood between myself and the trust," he stresses.

De Ridder worked in the trust's long-term lending arm and was responsible for establishing an effective delivery network before moving to the development arm. He became GM during a reorganisation of the trust in 1990.

Conradie says a successor hasn't been named and De Ridder's responsibilities will be handled by Francois van den Bergh.

De Ridder's new post involves establishing a property development facilitation company as a joint venture between the Rail Commuter Corp and the private sector. ■

LABOUR

Phone clash led to 'assault' with iron rod



Sowetan
A CLERK at a Pretoria insurance company has received eight stitches on the forehead after he was allegedly assaulted with an iron rod by a white manager during an argument at his workplace.

Atteridgeville's Mr Ben Ngwasheng also has a swollen left eye and cheek as a result of the assault which, he said, followed an argument over a telephone inside an office at Mutual and Federal Centre in Vermeulen Street on Monday morning.

Sowetan has established that Ngwasheng was later suspended - with full pay - pending the outcome of a disciplinary inquiry scheduled for today.

Ngwasheng received eight stitches at the HF Verwoerd Hospital, where he was treated and discharged soon after the incident.

Ngwasheng declined to comment on the matter.

An assistant manager of the company, Miss Denise Brown, also refused to discuss the matter.

"There is no statement but we will be dealing with the case," Brown said.

Ngwasheng's lawyer yesterday confirmed they had laid charges of assault against the senior white official. They also intended suing him.

Although they had laid charges and were given the

19/6/92
docket number of the case, police liaison officer for the Northern Transvaal Captain Andrew Lesch yesterday said the number did not reflect that case.

He asked Ngwasheng or his lawyer to contact him to clarify the matter.

Sowetan has established that Ngwasheng had an argument with two women staffers over the use of a telephone on Monday morning. An argument ensued and the white manager apparently intervened.

He was allegedly manhandled, punched and struck with an iron rod.

Brown declined to comment about allegations that the company was racist and denied blacks the right to use some of the company's facilities.

CAREER

Unlimited opportunity in banking

STAR 26/6/92

The most visible banking official, the teller, is to most customers the personification of banking, followed closely by the dignified person of the bank manager in the inner recesses of his important and sometimes slightly intimidating office.

But this is only the tip of the banking iceberg as far as careers are concerned. There are lots of other rewarding and exciting positions in the frontline-section and behind the scenes in every branch of a bank.

The many different departments in a bank form the branch structure, with the manager at the top. He is responsible for the lending of money to customers; making sure his staff are trained, competent and motivated; carrying out banking policies, and assuring efficient service to customers.

He also sells the bank's products by assisting and interviewing customers about their banking requirements; assisting potential customers and promoting the bank's

Modern banking has many facets. A future banker does not need to have only money in mind to choose a suitable career in banking.

products; and last but not least making sure that money lent to customers is repaid.

The branch administrator/controller/departmental head sees to the efficient running of the branch, which includes supervising and motivating staff, arranging for staff training and career development, making sure rules are kept, and interviewing customers on complex money matters.

Closely linked to the manager is the securities department, with staff functions such as the buying and selling of shares (that is, investing in a company listed on the Stock Exchange) through an authorised person (a stockbroker) on behalf of a customer; safeguarding valuables in the bank vault, taking collateral security for loans and overdrafts, and accepting applications for wills to the trust and will department on behalf of a customer.

The frontline section employs the staff who deal directly with customers. Here the teller mirrors the image of the branch and the bank. He or she must be friendly, courteous and efficient in dealing with customers, cashing their cheques, giving change, taking in deposits and using opportunities to introduce new products.

The inquiries department is the work area for people with excellent communication skills. This is where customers must get prompt attention to their needs, can be redirected to correct departments and where cheque books and statements are handed out.

The department functions along with the public relations officer, who reinforces the interest and co-operation of the frontline section.

The ATM official is the person who keeps money flowing by checking on the

automated teller machine, which we all use frequently, by seeing that the machine is working; attending to transaction queries of customers; and showing new customers how to use the machine correctly.

Behind the scenes in the cheque account section is the ledger department, where staff handle all routine matters concerned with cheque accounts.

The mandates department staff are responsible for taking, holding and keeping up to date the authority from customers who wish someone else to withdraw funds from their accounts or act on their behalf.

The foreign exchange (forex) section, which has a romantic sound about it, deals with the buying and selling of foreign currency in any form as long as it complies with exchange control regulations. This is the place where traveller's cheques are issued, foreign notes are bought and sold, and foreign cheques are made out.

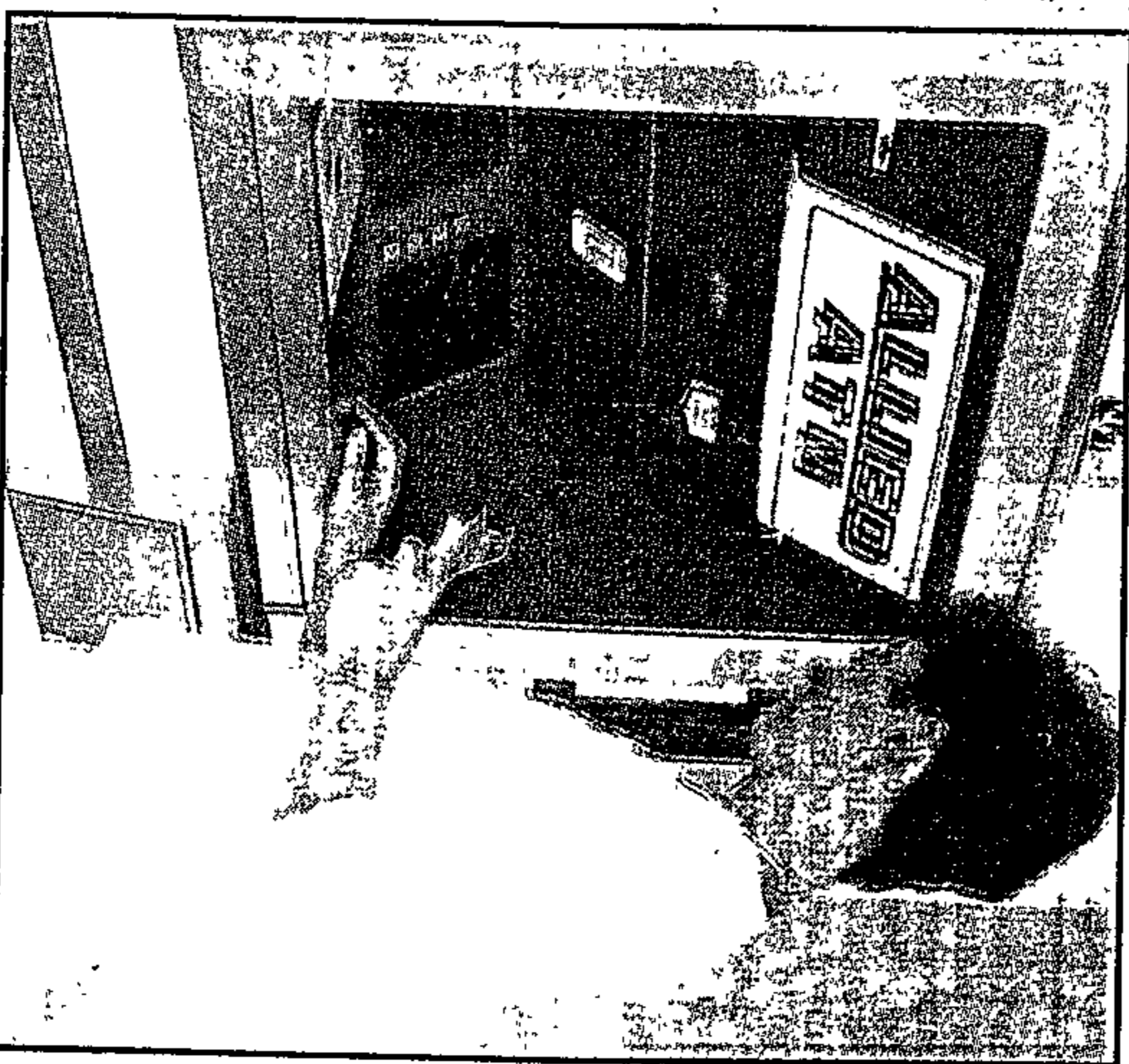

Ready cash . . . making sure automatic teller machines run smoothly is just one of many jobs in the banking sector.

To operate forex, the exchange control department sees to it that the rules of the South African Reserve Bank, which controls the movement of money in and out of the country, are met.
From *Lantern Cultural Journal*.



92 OR WHILE STOCKS LAST.

Bank post: Barend withdraws

By BARRY STREEK (59)

CT 27/6/92

THE recently retired Minister of Finance, Mr Barend du Plessis, yesterday withdrew his candidacy to be president of the Development Bank of Southern Africa following opposition to his possible election.

His nomination was opposed

by the ANC and the Transkei government, both of whom favoured a more neutral person.

Mr Du Plessis's predecessor as Minister of Finance, Mr Owen Horwood, who had earlier indicated that he wanted to retire, was re-elected president.

The State President's office

said yesterday that while an overwhelming majority had supported Mr Du Plessis, consensus could not be achieved among all member countries.

Mr Du Plessis indicated that he did not wish to break the tradition of nomination by full consensus.



Gang robs cops

I **enforced to**



Absa staff cuts could reach 4 400

BIDAY 23/7/92 SHARON WOOD (59)

Absa staff cuts could reach 4 400 during the group's rationalisation process, sources close to the bank said yesterday.

Absa human resources group executive Petrus Claasen said the staff complement had been reduced by 1 570 by end-July and he expected this number to reach 2 500 by end-September. Therefore, by end-September the staff rationalisation process would be only 60% completed.

Absa CE Piet Badenhorst said the rationalisation process was on schedule and he was happy with progress. He said there was no official target number for staff cuts.

Staff reductions have also led the group to vacate some of its rented office space.

Anglo American Property Services (Ampros) chairman Gerald Leissner said Absa had moved out of its rented space in the African Life building. The group was still paying rental because the lease ran for another three to four years, he said.

It is believed that the bank has moved out of other premises as well.

Leissner confirmed Absa would be negotiating upcoming leases on office space. In addition, he also expected movement out of retail space.

Ampros office leasing manager John Meynard said there had been a lot of movement by Absa, which was a part of its reorganisation, but that this had not affected Ampros.

Banking giant swoops in for kill, but...

NO takeover

Absa tells Boland

TOM HOOD
Business Editor

Absa had an interesting message for Boland Bank this week: 'We're not interested in a takeover'

THE country's largest banking empire — the R84 billion Amalgamated Banks of South Africa, formed from a series of mergers of takeovers — does not want to take over the Paarl-based R2,9 million Boland Bank after all.

This is the message from Mr Hennie Diederichs, operating executive of Absa's Trust and Volkskas banks and follows fears expressed when about 300 shareholders crowded into Boland's annual meeting this week.

"It is a very emotional issue," said Mr Diederichs in an interview in Cape Town. So emotional that former Cabinet minister Mr Hendrik Schoeman, now a Boland Bank director, was applauded when he told shareholders: "Volkskas

has one helluva ambition, and that is to takeover this bank. This is such a beautiful bank that it will take hell to take it over."

However, Mr Diederichs explained that Volkskas originally acquired its 10 percent of Boland Bank's capital from the Pickard group and held them as an defensive exercise. "We merely took the shares out of the market."

Both Boland and Volkskas were in a similar market segment and Volkskas was concerned that Boland could end up in the hands of one of its competitors.

Absa wanted reasonable representation on the Boland board of directors in relation to its shareholding but there appeared to be no basis for appointing directors — "It is a very closed shop," said Mr Diederichs

It is not an issue of taking over the bank. We want board representation and talk of takeover is not necessarily true.

MARC HASENFUSS, who attended the lively Boland meeting this week at Paarl's Toringerk, reports that it omnibusly coincided with a funeral service.

But the events at the AGM put paid to any suggestions

that the comparatively small Boland Bank would allow itself to be "buried" in a takeover attempt.

Boland's dogged determination to stay independent precluded Absa making a formal offer recently. Boland directors believe the bank would compromise its unique "platteland" banking culture and its close relationship with shareholders and clients if it was swallowed up by the banking giant.

In his opening remarks Boland Bank chairman Mr Pietman Hugo again emphasised the importance of the bank's close connection with its shareholders (whom he addresses as 'friends').

Although the meeting did not see a direct clash between Absa and Boland, periodic interjections by an Absa representative suggested that a takeover bid was still in the offing.

To the delight of Boland's shareholders, the long-winded Absa representative was asked by Mr Hugo not to deliver a speech but to just ask questions.

Responding to the threatening Absa presence, several shareholders committed their support to Boland Bank in strong worded statements.

To page 3

Bank merger will leave 200 workers 'surplus'

TOM HOOD
Business Editor

ABOUT 200 bank workers will become "surplus" in Cape Town as a result of the merger of the regional management offices of Trust Bank and Volkskas.

But 90 percent are expected to find other jobs because of vacancies elsewhere in the two banks, says Mr Hennie Diederichs, operating executive of Trust Bank/Volkskas.

This was the pattern elsewhere in the country and fewer than 10 percent of people on the surplus list would be retrenched.

The two banks, now part of the R85 billion Amalgamated

Banks of South Africa (Absa), control R3 billion of assets in the Cape.

The new regional team works from several buildings but will eventually move into one building.

Mr Diederichs said in Cape Town yesterday one aim of the "single, strong management" was to reduce staff to close to 17 000 from about 21 000 employed by the two institutions at the time Trust Bank's holding company, Bankorp, was acquired by Absa earlier this year.

Cost benefits of rationalisation would be passed on to customers in "more affordable banking", he said, adding that

the amalgamation of divisions such as computer services had reduced numbers in Trust Bank/Volkskas to roughly 19 000.

"Although it is a moving target, the aim is to end up with a little more than 17 000 staff," he said.

"Rationalisation became essential when the banking industry grew fat and lazy during the cartel era when banks fixed prices at will. The company has been revitalised. The lines of communication have been shortened, operating efficiency has been improved and the mood among the many top bankers we have in our management team is aggressive."

25/7/92

Urges

25/7/92

(579)

600 lose jobs as merged banks rationalise offices

ROY COKAYNE

PRETORIA. — The Trustbank/Volkskas operating division, part of giant banking group Absa, has completed its rationalisation — and halved the number of head and regional office staff in the division.

Volkskas/Trustbank operating executive Mr Hennie Diedericks said the division had had two head and 10 regional offices countrywide employing 1 200 people.

It now had one head office, five regional offices and employed 600 fewer people, he said in Pretoria.

"The cost advantages of the merging of the top management of Volkskas and Trustbank have been enormous. The cost savings have been in people employed, office space used and on other structures," he said.

Its branch network, which employed about 16 000 people and involved about 700 service points, comprised 302 Volkskas and 188 Trustbank branches, plus 216 Volkskas and 84 Trustbank agencies or mini-branches.

The pressure on costs, particularly with the low level of economic activity, was phenomenal, and all banks were under pressure, Mr Diedericks said.

Mr Diedericks said Volkskas had a 60 percent market share of the banking sector in Pretoria and it intended protecting and expanding this share.

He said Trustbank and Volkskas served a specific market segment and had a strong following of clients, and it did not make sense to force them together.

"While they will keep their names in the market place, their head offices and regional structures have been merged. The pooling of resources has given us one of the most experienced management corps in the country.

"There is one general manager controlling all Volkskas and Trustbank branches in each region. The banks share the same credit, administration and human resources services, but each has its own business development and client service team.

"Trustbank is a broadly based urban bank, while Volkskas is focused more on the Afrikaans-orientated community. Each has a spread of about 60/40 in individual, and business and professional clients," Mr Diedericks said.

Mr Diedericks said a more aggressive marketing campaign involving Trustbank and Volkskas focusing on the products offered by the two banks and the quality of service was about to begin.

Mr Diedericks said some products, such as a cheque account, had become expensive and they were about to introduce a new product that would address the question of affordability.

He said new products would be developed to cater for a broader client base in South Africa and include all language and population groups.

"We would like to have a broader base. The acceptability of Trustbank to other language and population groups is much bigger than that of Volkskas, but Volkskas also has the capacity to attract clients across these barriers," he said.

Mr Diedericks said it was too early to decide on how on their approach in the new South Africa.

"The new South Africa still has show its true colours. We will have to see who the major players are going to be before we can take a decision on whether we need to shake our feathers," he said.

● About 200 workers will become "surplus" in Cape Town as a result of the merger of Trust Bank and Volkskas regional offices. But about 90 percent are expected to find jobs elsewhere in the banks, according to Mr Diedericks.

LOA keeps tabs on agents' commissions

BIDAM 3/17/72 (59)
THE principle that brokers and agents should receive equivalent remuneration for the same level of production is important to the life assurance industry and the Life Offices' Association (LOA) says it goes to great lengths to maintain "equivalence of reward".

LOA deputy director Jurie Wessels says: "The maximum commission a life assurer may pay a broker is stipulated in the Insurance Act. The law says nothing about agents' commissions."

This is because agents can receive remuneration in a number of ways, such as company cars and housing subsidies, which would be complex to regulate.

"Because of the types of benefits mentioned, and also because agents get offices, secretarial services and equipment that brokers have to buy or rent, the cash component of agents' commission is much lower."

Anomalies

All of this makes it impossible to ensure equivalent commission levels through legislation, but the LOA monitors equivalence of reward, says Wessels.

"We point out any anomalies to the assurers and get them to bring their agents' remuneration in line with the regulations for brokers. We also report on these surveys to the Registrar of Insurance."

A small variation in favour of agents is allowed, mainly because agents do not have the options that brokers have in structuring their taxable income. For example, an agent has to use the offices provided by his employer, while a broker may have expensive offices (and a large tax deduction for expenses) or may decide to have cheaper offices and a bigger taxable income.

Wessels says: "We are aware that there are brokers who believe agents' commissions are too high. However, we do not believe that this is the case. One of our indicators is that many life assurance agents become brokers while few brokers become agents."

ar

Construction slowdown impacts on Blue Circle

STAR 27/8/92

Severely depressed activity in the building and construction industry has led to a 28,5 percent decline in Blue Circle's earnings to R27,8 million for the six months ended June.

Turnover at R376 million was R6 million down from the corresponding period in the previous year.

High capital expenditure and the seasonally higher working capital required during the first

half of the year resulted in substantially higher financing charges of R7,66 million compared with R742 000 previously.

This was however partially offset by a lower tax rate due to allowances on capex.

Tax paid amounted to R7,20 million compared with the previous amount of R15,33 million.

A dividend of 27,5c a share has been declared out of earnings of 82,3c a share. — Sapa.

London offers four bursaries for blacks

The City of London is to offer four bursaries to black employees of South African financial institutions, the Lord Mayor of London Sir Brian Jenkins said in Johannesburg yesterday.

Sir Brian said the bursaries would enable the four candidates to study further in financial and legal services at the London Polytechnic summer school.

Recognition

He said the bursaries were in recognition of the long-standing business connections between his city and South Africa and to mark the first visit to the country by a Lord Mayor of London since the Second World War.

Expanding on his purpose in visiting South Africa, Sir Brian said it was to sustain and support London's role as a business centre.

Transactions

London was the world's financial capital, outpacing both New York and Tokyo in terms of international business transactions, he said.

He pointed out that about twenty percent of the world's banks and insurance companies had their headquarters in the British capital city. — Sapa.

COMY DESKING

DESKS WITH SOLID EDGES

- 1 m x 1 m executive Toni desk..... NOW R1 769,95
- 200 sliding door credenza..... NOW R 899,95
- 800 x 850 double pedestal desk... R1 159,95
- 600 x 850 single pedestal desk.... R 759,90
- smaller credenza (John)..... R 631,40
- smaller L Extension (John)..... R 408,00
- bookcase..... NOW R 416,00

Free delivery CBD — Also chairs

- for imbuia filers 4-drawer..... R1 080,75
- 3-drawer..... R 902,00
- 2-drawer..... R 693,00
- double pedestal 1 800 x 900 desk..... R1 649,90

CALL IN AND INSPECT THE QUALITY

140 Commissioner St, cor End St, Jhb
Tel: 29-9517/8/9. Fax: 29-9524
Free parking in our basement

878

Estate agents 'need further education'

8105-1 2/9/92
THE need for continuing compulsory education in the real estate industry after the estate agents board exam is an issue newly elected president of the SA Institute of Estate Agents Ian Taylor intends to pursue.

"Many courses are available for people in the industry but, except for the board exam, none of these is compulsory, he said.

The main reason for continued education was to improve the quality of estate agents and protect the public, he said.

The institute would discuss the matter with the Estate Agents Board, but

Taylor said the first move would be to establish the groundwork for changes.

A lack of education among estate agents rather than a deliberate misleading of clients was the main reason behind most cases in which people had lost money or not received the best advice.

He said the quickest way to upgrade the level of education in the real estate industry was to have an examination for principals — estate agent owners or managers.

"This course should be compulsory before an agent is allowed to manage an estate agency office. A

principal who is fully trained can better advise his agents, and that in turn will protect clients' interests more fully.

In the US, which has been the world leader in real estate for some time, an estate agent has to complete a minimum number of courses a year before being re-issued with an operating licence.

While the institute already holds various annual seminars at its branches countrywide, and the National Property Academy holds formal courses, these needed to be extended, Taylor said.

CAREER

Learning to be a banker

STAN 17/9/92
As the bank can provide various ways for the trainee to become qualified, particular school subjects are not imperative, but commercial subjects such as Business Economics and Accountancy will be advantageous.

To apply for a position at a bank contact your nearest branch or visit the Personnel Selection Centre. Make an appointment for an interview, and take your identity document, your latest school results such as your Prelim marks, testimonials from your school and any other certificates for academic achievement which you may have with you when you go to complete the application form.

Permanent employment depends on whether your matric pass is considered satisfactory by the bank.

Modern banking covers a wide range of areas. Inhouse training enables staff to reach their fullest potential. Training material is designed and developed by a team of specialists to meet the specific needs of the staff-in-training. Inhouse-training has different facets.

● On-the-job-training:

A career in banking can start early in life. As soon as you have completed writing your matriculation examinations you can apply for a position in the bank.

here an expert in the branch will teach you how to do a particular job.

● Skills training modules: these modules consist of booklets, videos, audio tapes and computer exercises. The banker-in-training is allocated time during working hours to study training material.

● Platform training: some trainees are nominated to attend training courses at one of the bank's training centres. These courses consist of classroom lectures, a test and a follow-up assignment to complete at the branch where the trainee works.

The prospective banker is given a five-day orientation course on first joining a bank. On the very first day of orientation those questions concerning conditions of employment and the what, how, and where of a new environment — which

(59) ~~111~~
are often a mystery for months in a new job — are answered in a fun question-and-answer booklet.

With the help of a staff official or the branch administrator, the trainee banker will soon know for example when he/she will be paid, and how much; what will be deducted from the salary and the amount of allowances; how many days leave will be forthcoming and in which months of the year leave will be available; the names and titles of the supervisor and colleagues; working hours and the procedure for signing the attendance register; tea and lunch breaks; a job description, and administrative procedures such as the use of the telephone for private and official use, where to post letters, make photocopies and obtain stationery.

A further part of the orientation is the more intricate documentation like filling in the IRP2 form to register as a taxpayer; application for membership to a medical aid society and running an own bank account.

From Lantern Journal.

Estate agents hard hit

■ Scores quitting the profession because of recession:

By Joshua Raboroko

SCORES of estate agents were quitting the profession as a result of the recession, the Transvaal director of Pam Golding Properties, Mr Ronald Ennik, said this week.

There was, however, still a desperate need for trained, dedicated professionals in the job, he said.

"In fact, we are presently expanding and recruiting and have already been approached by a number of top agents from smaller companies."

But the market may be vibrant for a few black estate agents because of the

shortage of homes.

Secretary of the Soweto Builders Forum Mr Chris Jiyane said there were few black estate agents as a result of the policy of apartheid.

But the market was open and "we are working hard to compete favourably with our white counterparts", he said.

Ennik said in sharp contrast to the general trend, his company was expanding and they needed highly professional staff to support that growth.

"The exodus is from the bottom end of the market and consists of the people who in boom times think they can make easy money. The recession quickly flushes them out."

S9

'Blessings for hard work'

WORKING 16 to 18 hours a day would bring South Africans wonderful blessings, Dr Piet Koornhof, former South African Ambassador to the United States, told delegates at the annual conference of the Cape Assurance Insurance Industry Liaison Committee (CAILCOM) held in Cape Town.

He said hard work, humour and a positive mental attitude could carry South Africans through into the New South Africa, which would be an example to the world of how to live in peace and harmony. (59) (S)

ANC economist Patrick Ncube urged the promotion of small business to help create jobs. 27/9/92/1

He suggested innovative banking, credit guarantee schemes, group loans and the establishment of special financial institutions as a means of lending to the small and informal business sectors. *S Times (Cape metro)*

Nedcor Bank College opens

Blom 6/10/92
NEDCOR Bank yesterday officially opened its R2,5m Nedcor Bank College, offering employees a holistic banking education.

The college will start with a pilot group of 65 students, initially on a "floating" campus, using rented training facilities.

The curriculum offered at the college covers professional, life, utilisation and management skills (Plum) and includes study skills, self-image development, systems thinking, social interaction skills, marketing and decision-management. The course will interlink theory and practice.

It will also offer a number of basic core studies for the educationally or socially disadvantaged. These will include literacy, computer skills, assertiveness training and leadership development.

Most of the courses are registered with the Manpower Department, Darnelin and the Institute of Bankers and thus students will receive recog-

SHARON WOOD

nised certificates.

(59)
The group believes the college will make a contribution to the social reconstruction and normalisation of SA and that it will keep both the organisation and its personnel at the forefront of innovative thinking and creative competition.

"Our business logic and strategic planning indicate that to survive and remain competitive in our changing markets, we need to develop our future management now.

"Both from a business and socio-political point of view this urgently requires us to develop the skills of all racial groups in a non-discriminatory context," a statement says.

Candidates for the college will be selected through a combination of recommendations from management, personnel consultants and themselves. Students will have a strong say in their curriculum.

Try to say it with comics

South 10/10 - 4/10/92

COMIC strips usually amuse and entertain, but, as more and more life assurance schemes are finding out in South Africa today, they can also educate.

Employee benefits are a complex issue at the best of times, but during negotiations between workers and employers, workers are often at a disadvantage because they do not know enough about insurance, pensions and other benefits.

To help them, Old Mutual has pioneered easy-to-read comic strips to explain these complex issues to workers.

At least two are already in circulation. One has been produced for its employee benefits division and the other for Iscor.

They graphically explain the differences between, for example, pension funds and provident funds, why these are needed in today's society and what is done with the money in the fund to ensure that it grows and/or is used to back social programmes.

Explaining the move, Old Mutual's general manager in charge of employee benefits, Mr Garth Griffin, said negotiations about employee benefits were



usually highly emotional, with rhetoric and a lack of realism predominating.

"When participants better understand the issues and each other's viewpoints, it is possible to move quickly towards practical resolution — for the benefit of all," said Griffin. — **LYNDA LOXTON**

SA Federation of Business

Driven by a mutual respect

blom 28/10/92

LAST year's winners of the Gold Award, Southern Life, believes its corporate philosophy and culture creates a working environment that is conducive to bringing out the best in all its staff.

In its 27-page submission to the Gold Award judges, Southern outlined what exactly it had brought out in its staff "given the necessary flexibility and freedom to achieve the maximum they are capable of achieving", says public relations manager Sue Snow.

In the company's benefits division, the Marketer of the Year was a woman, as was the winner of the Chairman's Award, and of the 24 contributors of the month, 10 were female.

"Southern is gender blind," says Snow. This is evidenced by the fact that superior-subordinate relationships within the company, irrespective of the genders involved, are characterised by mutual respect and appreciation.

"We even have two males in secretarial posi-



At the top in Southern Life: from back left, Margaret Stevenson (corporate actuarial), Jennifer Preiss (legal and tax services senior manager), Brenda Doyle (assistant GM), Virginia Ogilvie-Thompson (Southern Foundation executive director), Trish Acton (computer audit senior manager), Ann Roux (employee benefits senior manager).

tions at Southern." At the same time an increasing number of women are being appointed to positions in areas previously regarded as all-male domains. Snow gives examples of store clerks, security guards and technicians.

Southern statistics on professional women are impressive: three out of the five full-time actuaries in SA work for the company;

one of its two economists is a woman, and out of a total of 36 underwriters 27 are women.

"Since 1988, Southern has been addressing the need for improved communication and enhanced relationships in the workplace via a specially developed programme called Equity," says Snow.

The programme covers differences in perceptions between cultural and religious groupings, between management and non-managerial staff, as well as between men and women.

Snow says this gives the 260 participants, evenly split between men and women, the opportunity to exchange ideas and share insights, beliefs and values.

Southern also looks after its employees through an employee care programme which provides staff with a 24-hour service to help them with financial-related dilemmas as well as drug and alcohol abuse, bereavement, depression, divorce, health, stress, suicide, violence, personal growth and personal relationships.

Handwritten initials or mark.

Handwritten mark or signature.

Last year's win gave us a boost — Southern

59
BIDA
28/10/97

WINNING the Gold Award in 1991 has done a great deal to enhance the image of the company in the eyes of the Southern Life employees, the purchasing public and prospective female employees, MD Jan Calitz says.

It has been a source of immense pride and pleasure to everyone at Southern, he says.

"But while it has been wonderful to receive official recognition for our achievements in the sphere of female advancement, it has also made us ultra aware of our enormous responsibilities as an employer of significant numbers of disadvantaged employees from other groupings in the SA workplace."

Calitz says the award has given the group a "huge incentive" not only to maintain the positive growth climate Southern has created for women, but also to devise new ways of empowering the full spectrum of the group's staff, "enabling them to all realise their true potential".

His sentiments are echoed by Southern's women staffers.

Deputy GM Brenda Doyle says Southern is a large organisation with a "small-company ethos".

She says she has never encountered any form of

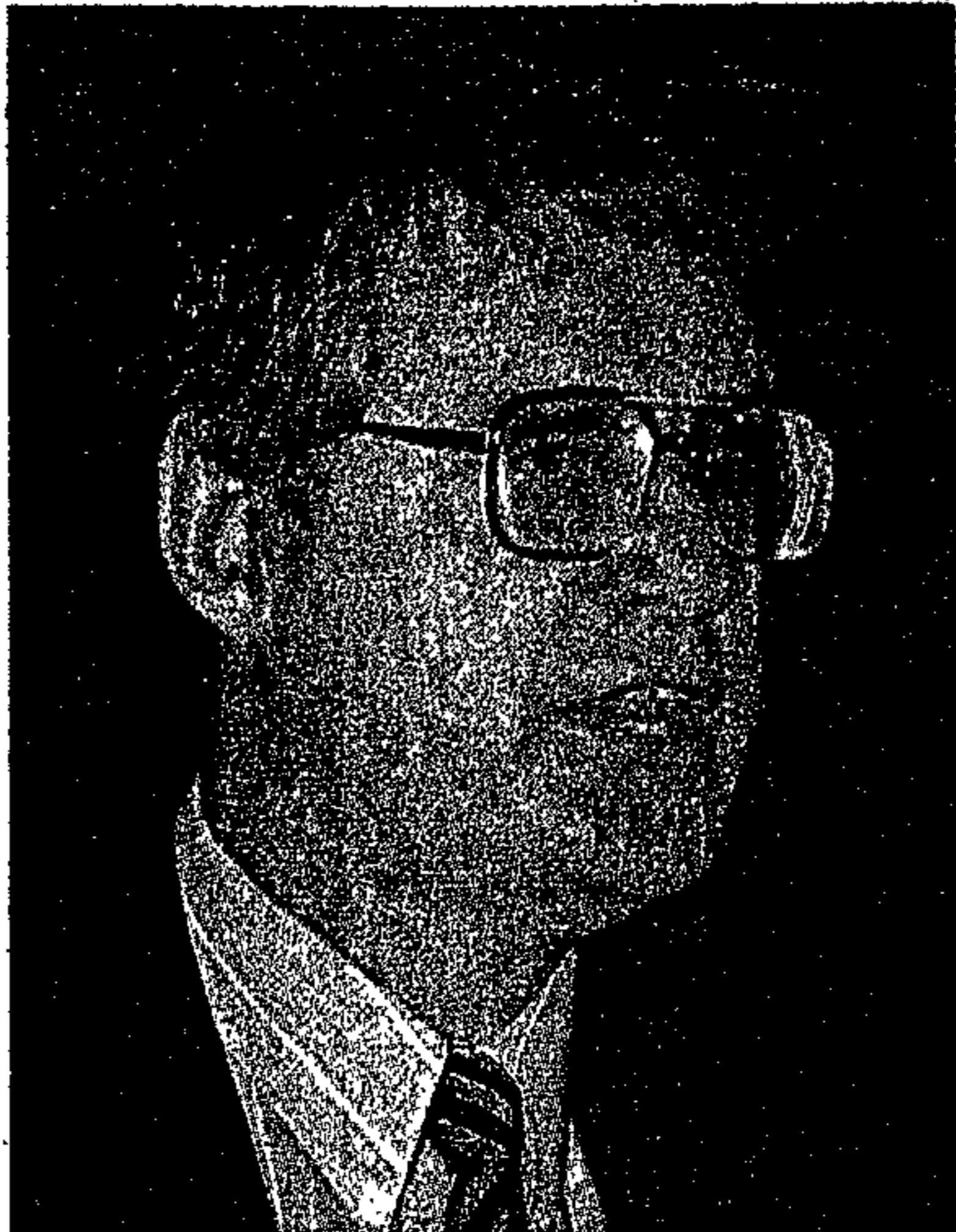

Award raises awareness of responsibilities ... Calitz

discrimination against women. "People are respected for their contribution to the company and encouraged to attain their maximum potential."

Assistant GM Jenny Carter says whatever opportunities arise in the organisation are open to women.

"If I have the ability and enthusiasm to do something, I am confident that I will be taken seriously."

She says that while there

is still the continuing challenge of confronting "ingrained male prejudice" on the part of some male colleagues, she does not allow their attitude to deter her, as discrimination is against the organisation's basic philosophy.

Working for a company like Southern not only makes it easier for women to have careers, but also encourages them to do so, says assistant GM Maureen Rawlins.

She says that the top managements' openness and ability to listen has removed any obstacles for career-minded women.

Senior manager Margaret Stevenson says the fact that she is a woman has never entered the picture at Southern.

"As Southerners we are in the unique and extremely fortunate position of being able to do whatever it takes for us to realise our personal aspirations and career ambitions in a corporate atmosphere that offers us freedom and flexibility as well as the necessary nurturing."

Winning the Gold Award has been an affirmation of the values of equality and will spur the company on to greater achievements, says senior manager Jennifer Preiss.

She says that given the history of discrimination against women in the workplace, Southern compares very favourably with other financial institutions.

Senior manager Trish Acton says that over the years she has seen the firm move away from an outdated paternalistic attitude towards female staff to a climate of empowerment.

"Today, as a woman at Southern, one has the right to aspire to any position in the company, knowing that one will be judged solely on merit and performance."

Fedsure wins employment policy award

INSURANCE group Fedsure won the SA Federation of Business and Professional Women's National Gold Award at a banquet in Sandton last night. (59)

The award is presented to the company which has actively promoted its female personnel to achieve career growth and status, based on ability and talent.

Guest speaker Francis Kendall said men and women differed and it was time to accept this. BIAA 28/10/92

More creative men would study and imitate any female skill which improved their competitive edge — and would be the first to devolve their businesses, Kendall said. These were the people who would value

JONO WATERS

the skills, working abilities and the high administrative competence of their women employees.

Companies could improve their productivity and competitive advantage by making use of the special and different skills of men and women, she added.

The award was judged from 21 qualifying companies and resulted in six finalists. The other finalists were Oxford University Press Southern Africa, Southern Life, Pick 'n Pay, Anglo Alpha and SPL.

● See Survey Pages 6-10

NATION BUILDING Absa and Wits show aspirant bankers the correct path with their diploma

Skill is the strong link in the chain

By Joshua Raboroko

THE acquisition of appropriate skills is a vital link in the job creation chain.

As part of its declared intention to help create job opportunities in the future, Amalgamated Banks of South Africa will launch, in conjunction with the Witwatersrand Technikon, a diploma in banking through full-time or part-time study at the beginning of 1993. The diploma will be comparable to a

HEAD START Knowing your stuff is the

best way to get right into the job market.

Bachelor of Commerce degree in the banking industry and will require three years of full-time or four of part-time study. Subjects will include banking, law for bankers, accounting for bankers, communications, economics and end-

user computing. The admission requirement will be matric Mathematics at higher grade level. Full-time students will be guaranteed weekend or vacation employment at ABSA branches to gain valuable practical experience, as well as useful income.

Part-time students will be recruited from ABSA's employee complement, with the focus on managers in the trading environment. Some 60 ABSA employees have already been enrolled for the first part-time course next year.

ABSA's human resource spokesman, Mr Fanie du Toit, says the project will provide South Africa with much-needed professional bankers in the years to come.

"Both the courses will offer a curriculum focused on the needs of a banking professional, with ample opportunity for hands-on practical experience in the ABSA branch network," he noted.

Costs of the courses will be about R5 000 and salary earned while gaining practical experience may be used to defray the expense. Potential applicants should write to the Human Resources Department, ABSA Bank, PO Box 7735, Johannesburg, 2000.



Bankers walk out on Sechold

S/Time/B455/15/11/92

By JULIE WALKER

NDH BANK'S principal staff members walked out of their new Rosebank premises in Johannesburg this week after major shareholder Sechold rejected a backed bid by management for its 75% stake in NDH.

NDH is a respected and profitable trader. NDH management holds the 25% not in Sechold hands.

Managers are said to be unhappy about the way Sechold rewarded them in the light of good profits from NDH.

Sechold chief executive Arthur Kelly says the board rejected the bid for NDH. Certain management and staff members from NDH indicated their intention to leave the bank and pursue their own interests.

NDH directors Bill Scotcher (also on the Sechold board) and Dave Barber confirm Mr Kelly's statement.

Another director, five dealers and an accountant

are part of the mutiny.

Sechold has appointed Craig Clucas and Michiel Kotze joint managing directors of NDH. Mr Kelly expects NDH to continue to achieve satisfactory profits under new management.

The bid was backed by an undisclosed third party — most market sources suggest NBS Holdings. But NBS general manager, finance, Paul Leafwright denies the talk.

He confirms that since the failed bid, NBS has been talking to Mr Scotcher and company, but any decision on their engagement will need to be taken by the NBS board.

It remains to be seen how NBS directors would enjoy appointing a team of dealers used to earning R500 000 or more a year — more than they could realistically hope to earn as directors.

SAA laying off 2 200 in face of huge losses

By ROGER MAKINGS

S/Times (Buss) 22/11/92

SAA will reduce its workforce by at least 2 200, mostly through voluntary severance packages.

However, those who do not leave of their own accord may find themselves being retrenched with a less favourable pay-out.

It is believed that a "considerable" number of employees have accepted voluntary severance packages.

But those who reject the first-phase option could be retrenched in months to come in a second round of reductions.

Both middle and top management will be affected by the cutbacks.

Not all those leaving are sub-standard performers unsure of whether they can hold down their jobs.

Nutshell

Without naming anyone, SAA chief-executive-elect Mike Myburgh says that among those who have elected to go are excellent managers capable of making a "career elsewhere".

"Some of them are the sort of people we would have liked to have kept, but this would have demotivated them to the point that it would be better to let them go.

"In a nutshell, we hope that those who are under-achieving are aware of the fact and will elect to leave. But if they don't, we will have to retrench them."

It is believed it will cost SAA less than R10-million to pay off 20% of its complement off 11 000. By cutting 20% off its annual salary bill of about R700-million, SAA stands to save R140-million a year.

A further 10% of R70-million will be saved by pegging salaries.

Overheads

SAA's losses for the year are expected to be more than R200-million.

It employs more than 300 people an aircraft compared with an average of 236 in similar-size airlines around the world — a difference of 29%.

Besides staff cuts, SAA will rationalise overheads — like unprofitable routes — with the combined savings being poured back into the airline.

Mr Myburgh says: "We are looking to improve our ser-



MIKE MYBURGH: Those who don't get the message will be told to go

vice to passengers by motivating staff through refresher training. In effect, we are putting our faith in our staff".

Also planned is greater investment in technology — such as wider use of seat-back video screens and more efficient aircraft so as to compete on an equal footing with international carriers flying into SA.

Stronger alliances with other Southern African carriers are also envisaged.

Mr Myburgh says: "We must broaden our base in the region and become a useful ally to our neighbouring carriers.

"In this way we will have more clout with the incoming international airlines who will become more dependent on us to get their passengers into the interior".

Premium blow faces brokers

By TERRY BETTY

EARNINGS of insurance brokers will drop because they will no longer be allowed to hold premium income for long.

Registrar of Financial Institutions Nico Fourie has, against the advice of short-term insurers and brokers, amended regulations governing Section 20 bis of the Insurance Act with effect from the beginning of December.

Brokers receiving commission from customers will have to pay the money to the insurance companies 15 days after the end of the month in which it is received.

At present, brokers have to pay the insurer about 40 days after the month the premium falls due.

SA Insurance Brokers Association (SAIBA) vice-president Rod Maitland says several joint representations with the SA Insurance Association (SAIA) were made against the ruling. But the Registrar refused to back down.

Mr Maitland says brokers depending more on their investment income than on commissions will be under pressure if they had an efficient collection system.

He says the existing system was introduced only two years ago and is working well.

The main problem is the cost and inconvenience to insurance companies and brokers, who at great expense introduced administrative procedures and computer systems. They will now have to alter their systems.

For some companies it will merely involve changing programmes. For others, it will involve a costly change to computer systems.

Mr Fourie says the intention is to get the money from customers to the insurer as

soon as possible.

He says it is not the role of the Financial Services Board to control market enterprise.

"The brokers are not really entitled to the investment income anyway. They are agents for the insurance companies and not principals."

Mr Fourie says: "Once the intermediary is in possession of the cash, there is little reason why it cannot be paid by the 15th of the following month.

"It is also realistic because insurance companies have to remit VAT on the premiums on the 25th of the month the money is received. It is unfair to make them pay VAT on funds they have not received."

A source says it seems strange that insurers would object to the change because they will theoretically receive the cash earlier.

Major

SA Eagle managing director Peter Martin says insurers will receive some money faster. But the present system works well and he sees little reason to change it.

Mr Martin says it will be a major problem for brokers handling the business of a large group of companies. Often the brokers have to collect premiums from all the subsidiaries.

Not all payments go through brokers. Mr Martin says 50% to 60% of personal lines business is paid through brokers. About 80% of commercial and industrial premiums pass through brokers.

He says this is necessary because brokers have records of all customers, are in direct contact with them and know the premium amount.

First solar battery

FIRST National Battery is to launch the first range of commercially produced solar-power batteries early next year. Until now, batteries designed for solar applications have been imported at great expense. First National believes their introduction will help to promote the use of solar power in SA.

company loan? And c
? And c
? And c

WILL your employees who seek priv

Supreme brokers rebuked

BLOM 3/12/92 (59)
FIRST Bowring & Associates has suspended four of its brokers for contravening their conditions of employment and placing clients' funds with the Supreme group.

This move follows the announcement by Absa on Tuesday that it would take action against any of its brokers who had contravened policy by promoting investments in Supreme. It is believed that nine brokers are being investigated and could face suspension or dismissal.

First National Bank spokesman Norman Axton said yesterday none of FNB's staff were involved in placing clients' money in Supreme, but brokers from its 50%-owned subsidiary First Bowring had been found to have done this.

"This goes against our terms of reference as any investments outside the group have to be authorised by national management and this was not done in some cases," he said.

First Bowring life director Charles van Rensburg said the company had been investigating the extent of its involvement. Four of its brokers had been suspended already.

"We have had a few customer inquiries and know of a few brokers who were involved in placing clients' money with Supreme. However, they were acting outside their scope of employment as any investment outside the group needs written management approval."

Although its involvement seemed limited at the moment, one broker had concluded 30 deals with Supreme on behalf of FNB clients. Each of these cases would be considered, he said.

However, a major problem was that there were no records of these deals. First Bowring was taking the matter "seriously" and would do everything to ensure the best interests of its clients were upheld, Van Rensburg said.

PETER GALLI

Standard Bank financial services MD Gavin Dingley said none of its clients had reported investments made with Supreme.

"We have had only one such incident and that was in 1990 when one of our consultants in Natal encouraged bank clients to place funds in Supreme. This was followed by disciplinary action," he said.

The bank had a clear policy that clients' funds had to be investments within the group, except for assured investments. This policy formed part of any consultant's conditions of employment, he said.

In the 1990 incident the broker had placed the commission from the deals in his personal account, which constituted theft. The bank had written to the customers involved explaining that the consultant had acted outside his brief.

"We told them we would become involved to see that they were not prejudiced if this became necessary while that investment was held. But should they choose to roll this investment over, we would not be liable."

If any claims arose as a result of the provisional liquidation of Supreme Holdings and Supreme Investment Holdings, the bank would examine each case on merit, Dingley said.

Nedbank commercial division director Jack de Blanche said he had received no reports of the bank's brokers having invested clients' money with Supreme.

"At the time of the Masterbond collapse, all staff were instructed not to invest funds with any other financial institution except those specifically identified by us," he said.

Sues. He said the Sunday Times report was based on PAC minutes of the... He will "fight fire with fire" against... called," Alexander said.

Absa suspends broker

ANDREW KRUMM



ABSA has suspended one of its United Insurance division brokers whose placement of investments in the Supreme Group had "required the most urgent attention", financial services MD Louw van Wyk said at the weekend. The Durban-based broker's services had been suspended pending an investigation which could lead to a disciplinary hearing. Louw declined to disclose the amounts involved, but said they were not in the millions.

Six other Absa insurance brokers — four United Insurance division employees, one Volkskas broker and a Bankorp employee — who had acted contrary to instructions, bank policy or their contracts, were also under investigation. 15/10/91 7/12/92

"It seems in these cases there was not too much money involved; most of the amounts were relatively small."

Last week First National Bank and the Standard said none of their brokers dealt with Supreme on behalf of clients with the exception of one Standard Bank employee, who had faced a disciplinary hearing in 1990.

However, First Bowring suspended four brokers last week for contravening their conditions of employment by placing funds in more than 30 deals with the Supreme Group. First Bowring director Patrick O'Flaherty said at the weekend investigations were continuing although no other employees had been suspended.

Plan to discredit CCB alleged

8/10/91 7/12/92

A PLAN co-ordinated at ministerial level and involving sinister co-operation between the security police, Military Intelligence and senior Defence Force officers to discredit the Civil Co-operation Bureau and turn it into a scapegoat for all the sins of the security forces had been put in operation in 1989, former CCB MD Col Joe Verster has alleged.

According to transcripts of Verster's in-camera evidence to the Webster inquest, which were made public on Friday, the covert CCB had become an offering on the altar of future co-operation between government and the ANC.

Verster alleged a "strategic communication operation" known as a Stratcom had been developed to discredit the CCB. Stratcom involved the deliberate creation of a certain milieu and the influencing of public opinion through selective disclosures to the media and other means.

Verster told the inquest into the May 1 1989 murder of Wits University academic and anti-apartheid campaigner David Webster he could not say if Stratcom had the blessing of government, but according to information available to him certain senior Ministers had been involved. Verster named Minister of Justice Kobie Coetsee, former Minister of Defence Gen Magnus Malan and former Minister of Finance Barend du Plessis.

Verster said former MI chief Gen Rudolph "Witkop" Badenhorst had also been involved in the project. Badenhorst headed an internal investigation into the Webster killing in January 1990.

Verster said Badenhorst and former head of security police Gen Basil Smit worked together to make CCB members "fall guys". Verster also alleged that people as senior as SADF head Gen Jannie Geldenhuis and then head of special

forces Gen Kat Liebenberg not only knew about the creation of the CCB, but would have had to authorise it. He said he was unable to say whether Malan would have known, but said he had access to documentation about its 1986 creation.

It emerged during cross-examination of Verster that he had written a letter to President F W de Klerk in May this year alleging that during the Harms Commission of Inquiry into politically motivated crimes, then CCB chairman Gen Eddie Webb gave orders that certain documentation and CCB files be destroyed. Verster said none of the files had anything to do with the Webster incident.

Portions of the letter were read into the record. The inquest was adjourned on Thursday until January when closing argument will be heard. Further transcripts of Verster's evidence have yet to be made public. — Sapa.

TOURISM Minister of ANRU 8/10/91 7/12/92



Nedcor union declares a dispute

THE largest of two unions organising Nedcor's 16 000 employees, Nedcor Staff Society, has declared a dispute after the bank tried to impose a joint bargaining forum and threatened to cancel its recognition agreement.

A Nedcor Staff Society spokesman said Nedcor declared a dispute with his union last month after it refused to participate in a joint bargaining forum with the Financial Services Workers' Union.

He said Nedcor had tried "unilaterally" to impose the forum after six years of separate negotiations.

"The conditions of workers in Nedcor differ widely because of the incorporation of Perm, Syfrets and UAL with Nedbank. Nedcor wants to

59 DIRK HARTFORD ~~134~~
use the joint forum to impose uniform conditions on us all," he said.

Nedcor had also given notice to withdraw recognition, threatened to discontinue negotiations unless they happened in the joint forum and threatened to impose on the staff society any settlement reached with other unions. *BIDM 9/12/92*

Nedcor's "heavy-handed conduct" and "bad faith bargaining" had forced the staff society to declare a dispute.

The spokesman refused to be named for fear of victimisation.

Nedcor could not be reached for comment last night.

B/DATY 10/12/72	Nedcor dispute (59) NEDCOR spokesman Phillip Bacchioni confirmed that the company's dispute with the Nedcor Staff Society (NSS) would be heard at a conciliation board meeting next week. He said while Nedcor did not agree with the grounds of the NSS complaint against the firm, Nedcor had declared the dispute to get the NSS to accept bargaining in a joint forum with the other union organising in the bank.
--------------------	---

NEWS Husband left home to gas himself ● Series of gospel shows start on Sunday

Bank employees face probe

By Ike Motsapi (59) *Sowe fans 11/12/92*

POLICE are investigating several employees at a First National Bank branch in Soweto for fraud believed to involve thousands of rands.

This was confirmed by Soweto police spokesman, Captain Joseph Ngobeni, yesterday.

Ngobeni said the investigations were isolated and concerned individuals and not the bank itself.

The manager of the branch, Mr Anthony Lolwane, also confirmed that one of his employees was subject to a police investigation for fraud.

He, however, said the money involved was "minimal".

And another bank employee who was believed to have been one of the people

being investigated, committed suicide last week.

Obed Morekore, (43), gassed himself in his car last Wednesday night, according to his wife, Mrs Favourite Morekore.

She said her husband had been "depressed lately" and that she had had no time to ask him what was worrying him.

Morekore said it was however "a mystery as to why Obed killed himself".

She said the family was puzzled about the incident.

She said: "My husband returned from home earlier than usual last Wednesday. He did not say anything. He unpacked all the goods that he

had with him and left the house. The family did not suspect anything. We became worried when he did not return home that evening.

"The following day, about 9.30am, police came to our Magaliesig, Fourways, home where they found my daughter Wandile.

"I had just gone out.

"They showed Wandile his identity document and asked her to identify that person.

"When she did the police broke the bad news to her," she said.

She said police had told the family that Morekore was found dead in his car at the West Fourways Mall along Wilkoppen Road on Thursday morning.

Gospel group Mighty Clouds of Joy arrives

Grammy winners to perform all over the country:

By Victor Metsamere

TOP American gospel music group Mighty Clouds of Joy arrived here last night for a series of shows starting in Bophuthatswana on Sunday.

The group, a three-time Grammy Awards winner, arrived without fellow group member Elmo Franklin, who is believed to be ill.

The group's tour is promoted by Fame Casting and Artists Agency.

Group leader and founder member Joe Ligon said they were happy to be

in Africa where the origins of the black man were anchored.

"We promise the South Africans gospel music lovers, particularly our loyal fans, good gospel music and high-energy presentations which should be worth their money."

The group will perform at Odi Stadium in Bophuthatswana on Sunday at 4.30pm. Other shows will take place at Village Green Theatre in Durban on December 16; Standard Bank Arena in Johannesburg (December 18); and De Beers Stadium in Kimberley (December 19).



Plans to beef up security of investors

BIDAM 1/21/92 GRETA STEYN (59)

FORMER London Stock Exchange chief surveillance officer Bob Wilkinson has made 37 recommendations on surveillance at the JSE after an investigation arranged by the Financial Services Board.

FSB executive officer Piet Badenhorst said in the annual report yesterday Wilkinson's recommendations were being followed up with a view to implementation. The FSB wanted to improve investors' security "with regard to the conduct of stockbrokers and the dealers of institutions who conduct business with stockbrokers".

A request for the appointment of a commission of inquiry into the finances of medical aid schemes and their unequal competition with insurers had been made.

Badenhorst said the FSB believed "the existing pay-as-you-go method of financing has resulted in serious financial problems for a large number of medical schemes and that enabling legislation for improved financial supervision of these schemes is of the utmost importance for the members of these schemes".

The report also noted the privatisation of public sector pension funds was on the cards. The FSB was involved in drawing up enabling legislation for registration of public sector pension funds as private funds. BIDAM 1/21/92

It saw its future challenges as integration of financial services, rationalisation of institutions and services, extending self-regulation and consumer protection, enhancing investor protection, educating investors and technological development.

The majority of FSB staff members had come from the private sector, thus augmenting the expertise in actuarial, accounting, legal and management personnel. But there were several areas where expertise had to be introduced.

● See Page 3

STAR 15/12/92

100 000 formal sector jobs lost in painful '92

By Thabo Leshilo
Labour Reporter

Close to 100 000 formal sector jobs were lost during 1992 and workers experienced a sharp decline in real wages, experts have told The Star.

The South African Chamber of Business put the number of jobs lost in the private sector at 85 000 and the public sector at 5 790 by the second half of this year.

A spokesman said the mining industry shed 29 000 jobs, manufacturing 35 000, construction 18 000, commerce 3 500 while the service sector, which includes finance, banks and insurance, employed 2 220 more people.

Steel and Engineering Industries of SA (Seifsa) executive director Brian Angus said the metal and engineering industries had, since the beginning of the year, cut staff by 49 000, bringing the industry to its lowest workforce in 20 years.

According to the Chamber, 300 000 jobs have been lost

since the second half of 1989, which marked the beginning of SA's longest recession.

The situation is even bleaker considering that only 4 percent of the country's approximately 250 000 matriculants are expected to find employment in the formal economy in 1993.

Research by industrial relations consultants, Andrew Levy and Associates, shows that on average, wage increases were far below the inflation rate for the first time in six years — from 16,1 percent in 1991 to 12,6 percent this year.

However, there was still some hope that things would shape up next year said Cosatu negotiations co-ordinator Jayandira Naidoo.

"Although the National Peace Accord was grounded this year, it has now been consolidated, raising hopes for a political settlement next year, which is vital for an upswing in the economy."

Naidoo hailed the creation of the restructured National Manpower Commission

(NMC) and the National Economic Forum (NEF) and the talks between Cosatu and the SA Consultative Committee on Labour Affairs as "the most positive" developments.

"A big plus for the labour movement was the extension of Basic Conditions of Employment Act to farm and domestic workers."

Added Angus: "It has been a very difficult year for employers in the metal and engineering industries, marked by a lot of confrontation and resort to legal proceedings".

Due to a deterioration in the economy, the industries were forced to settle for the "quite low" wage increase of 9,1 percent after strikes by the National Union of Metalworkers and the Metal and Electrical Workers' Union.

"Now that events of 1992 are behind us, we hope to make progress regarding the future of the industry and training next year."

Angus predicted the economy would pick up during the first half of 1993 if negotiations were back on track early in the new year.

Skills shortage best overcome by improving Black training

By Stephen Cranston

Severe skills shortages at senior and middle management level will be the most important challenge facing the insurance broking industry in the next 25 years, says Mike Hofmeyr, managing director of PFV Insurance Brokers.

"Our industry will be competing with insurers and reinsurers in a shrinking labour pool for the people with the best skills," he says.

In the top seven life companies, black managers represent 2,7 percent of black staff, while white managers represent 28,1 percent of white staff.

"In South Africa unequal and inadequate education, the brain drain of the '80s which dealt the insurance industry a severe blow, and very low immigration figures have combined to create these skills shortages, as well as an education shortage at entry level.

"We face a desperate shortage of managerial,



Mike Hofmeyr ... "tokenism is out."

engineering and technological skills," he says.

Technology in the insurance industry represents an ideal opportunity to cut down on unnecessary duplication of activity between insurers and intermediaries.

With greater trust and goodwill between the two parties this shortage will not exist 20 years from now. Electronic Data Interchange will

easily facilitate this.

While technological innovation in manufacturing most often emanates from materials and methods, in service industries the primary wellspring is information.

"Data is the most valuable raw material which service firms possess even though it never appears on the balance sheet. We are going to need people with the skills to process this data into a format upon which management decisions can be based."

The ANC has already outlined its future stand on business with calls for affirmative action and economic empowerment of blacks, including the acquisition of knowledge, skills and expertise.

"Proactive support and encouragement on joint ventures and partnerships with black enterprises and black people in general are also sought."

Hofmeyr argues that, in the light of this, "tokenism is out of the question."

Cosmetic situations, such as firms owned by whites but fronted by blacks, will be exposed for what they are, and lose credibility with the public.

"There are predictions that more than 20 percent of the clerical labour force will be black by 1995 and at senior level, predictions are that companies in the insurance industry will have in the region of 10 percent black executives by then.

"Insurance companies are spending between two and three percent of their income on training — and this figure will have to double within the next four years.

"We may see organisational structures change quite dramatically as the skills shortage deepens, since most organisations which follow popular management wisdom based on divisionalised structures and decentralised authority, will have to move to functional structures with more centralised control and better use of skills over a wider front."

Warning signals to watch for

59
~~fraud~~
~~fraud~~
~~fraud~~

S TARZ 21/12/92

THERE are 10 specific symptoms that should arouse suspicion of fraud in your company, says JCCI president Stuart Morris:

- A dominant chief executive or manager who often short-circuits any established systems or controls.
- Lifestyles of staffers that are out-of-line with their pay packets, or sudden changes in lifestyles.
- Key staffers in financial posts who are over-protective of their particular job routines, rarely take holidays, work excessive overtime.
- Poor segregation of duties between staffers, leaving

room to compromise any controls and leaving scope for fraud or theft.

- Slack accounting systems, spotted by the failure of accounts to balance accurately or the absence of explanations why settlement of any accounts was long overdue.
- Lack of understanding of key controls, especially in any computerised systems centred on one specific staffer.
- Loopholes that could allow kickbacks or bribes.
- Schemes that linked management pay packets to short-term results rather than longer term corporate strategies.

● Unnecessarily complex group or joint-venture structures.

● Staffers susceptible to temptations to grab any opportunities to swindle the company.

Low morale and lack of motivation were other danger signals, along with understaffing and poor management systems.

"Many of these indications in themselves are common-sense items and may seem obvious," says Morris. "They should not be underestimated."

"The adage that prevention is better than cure is never truer than in the case of

fraud. "The ideal solutions lie in forms of control that will limit the possibilities of fraud occurring. The dilemma is that a routine function is a predictable control and therefore one which can be avoided or over-ridden by the enterprising fraudster."

Basic preventative measures should include a corporate code of conduct, effective internal controls, thorough reference checks on new employees, more management focus on day-to-day operations, and tighter auditing procedures.

Business World reels

STAR 2/11/92

THE business world has been stunned by disclosures that no less than R1 billion may be involved in office scams that have been uncovered in a new crackdown on white-collar crime.

The Office for Serious Economic Offences, a special unit created by the Minister of Justice to counter the increasing complexity of rackets run inside business, such as computer fiddles and high-finance dodges around foreign exchange controls, confirms that a new wave of arrests of fraud suspects is imminent.

The roll-call of businessmen joining the rogues gallery of fraud culprits is also likely to be swollen at the end of an even longer list of investigations being handled by the SAP Commercial Branch.

Johannesburg Chamber of Commerce and Industry (JCCI)

A crackdown on white-collar crime looks poised to expose yet another wave of fraud suspects. New guidelines have been prepared to alert business executives to danger zones, writes **MICHAEL CHESTER**.

experts estimate that the number of fraud cases coming to the surface has grown by as much as 66 percent in the past five years. Even worse, the value of swindles has rocketed by a phenomenal 700 percent.

JCCI president Stuart Morris, himself a specialist in fraud detection as deputy chief executive of the KPMG Alken and Peat firm of accountants and auditors, has made a personal analysis of the problem — and now produced a set of guidelines for companies to follow in a counter-attack on the crime wave.

The first prerequisite, he believes, is that company direc-



Specialist in fraud detection
... Stuart Morris.
daily basis."

On the other hand, it was management that discovered most cases of fraud — 40 percent as a result of internal audits they initiated and an additional 25 percent by accident in office routines.

One special tip to employers was to ensure that staffers made regular use of their leave and time-off entitlements. □

Under Scams Shock

SCHEDULE

1. In this Schedule "the Regulations" shall mean the regulations published under Government Notice No. R. 2507 of 19 November 1982, as amended by Government Notice No. R. 2354 of 27 September 1991.

2. The Annex of the Regulations is hereby amended by the insertion in the correct alphabetical position of the item listed in column I below with the corresponding particulars listed in columns II and III:

I Foodstuff	II Anti-caking agent	III Conditions and limits (mg/kg)
Dextrose.....	Microcrystalline cellulose	10 000

No. R. 3418

24 December 1992

THE SOUTH AFRICAN MEDICAL AND DENTAL COUNCIL

REGULATIONS RELATING TO THE REGISTRATION OF ADDITIONAL QUALIFICATIONS BY OPTOMETRISTS: AMENDMENT

The Minister of National Health has, in terms of section 61 (1) (o) of the Medical, Dental and Supplementary Health Service Professions Act, 1974 (Act No. 56 of 1974), on the recommendation of the South African Medical and Dental Council, made the regulations set out in the Schedule hereto.

SCHEDULE

1. In this Schedule "the regulations" means the regulations published by Government Notice No. R. 1103 of 30 May 1984, as amended by Government Notices Nos. R. 2469 of 28 November 1986 and R. 2352 of 23 October 1987.

2. Regulation 2 of the Regulations is hereby amended by the addition of the following qualification under the heading "United States of America":

<i>University or examining authority and qualification</i>	<i>Abbreviation for registration</i>
<i>American Academy of Optometry</i>	
"Fellow	FAAO".

DEPARTMENT OF TRADE AND INDUSTRY

No. R. 3415   24 December 1992

ESTATE AGENTS ACT, 1976

CODE OF CONDUCT

The Estate Agents Board, with the approval of the Deputy Minister of Trade and Industry, acting on behalf of the Minister of Finance and of Trade and Industry, has in terms of section 8 (b) of the Estate Agents Act, 1976 (Act No. 112 of 1976), framed the Code of Conduct as set out in the Schedule hereto.

BYLAE

1. In hierdie Bylae beteken "die Regulasies" die regulasies afgekondig by Goewermentskennisgewing No. R. 2507 van 19 November 1982, soos gewysig by Goewermentskennisgewing No. R. 2354 van 27 September 1991.

2. Die Aangangsel van die Regulasies word hierby gewysig deur die item aangedui in kolom I hieronder, met die ooreenstemmende besonderhede aangedui in kolom II en III, in die korrekte alfabetiese posisie in te voeg:

I Voedingsmiddel	II Anti-koekmiddel	III Voorwaardes en perke (mg/kg)
Dekstrose.....	Mikrokristallyn-sellulose	10 000

No. R. 3418

24 Desember 1992

DIE SUID-AFRIKAANSE GENEESKUNDIGE EN TANDHEELKUNDIGE RAAD

REGULASIES BETREFFENDE DIE REGISTRASIE VAN ADDISIONELE KWALIFIKASIES VAN OPTOMETRISTE: WYSIGING

Die Minister van Nasionale Gesondheid het kragtens artikel 61 (1) (o) van die Wet op Geneeshere, Tandartse en Aanvullende Gesondheidsdiensberoep, 1974 (Wet No. 56 van 1974), op aanbeveling van die Suid-Afrikaanse Geneeskundige en Tandheelkundige Raad, die regulasies in die Bylae hiervan uiteengesit. uitgevaardig.

BYLAE

1. In hierdie Bylae beteken "die Regulasies" die regulasies afgekondig by Goewermentskennisgewing No. R. 1103 van 30 Mei 1984, soos gewysig by Goewermentskennisgewings Nos. R. 2469 van 28 November 1986 en R. 2352 van 23 Oktober 1987.

2. Regulasie 2 van die Regulasies word hierby gewysig deur onder die opskrif "Verenigde State van Amerika" die volgende kwalifikasie by te voeg:

<i>Universiteit of eksaminerende liggaam en kwalifikasie</i>	<i>Afkorting vir registrasie</i>
<i>American Academy of Optometry</i>	
"Fellow	FAAO".

DEPARTEMENT VAN HENDEL EN NYWERHEID

No. R. 3415

24 Desember 1992

WET OP EIENDOMSAGENTE, 1976

GEDRAGSKODE

Die Raad vir Eiendomsagente, met die goedkeuring van die Adjunkminister van Handel en Nywerheid, handelende namens die Minister van Finansies en van Handel en Nywerheid, het kragtens artikel 8 (b) van die Wet op Eiendomsagente, 1976 (Wet No. 112 van 1976), die gedragskode soos in die bylae hierby uitgevaardig.

SCHEDULE
1. Definitions

In this code of conduct, unless the context otherwise indicates—

- (a) **“board”** means the Estate Agents Board;
- (b) **“candidate estate agent”** means a person referred to in paragraph c (ii) of the definition of “estate agent” in section 1 of the Act who has subject to the provisions of Government Notice No. R. 1469 of 29 June 1990 been exempted from the standard of training prescribed by Government Notice No. R. 1409 of 1 July 1983;
- (c) **“client”** means a person who has given an estate agent a mandate, provided that should an estate agent have conflicting mandates in respect of a particular immovable property, the person whose mandate has first been accepted by the estate agent, is regarded as the client;
- (d) **“estate agency service”** means any service referred to in subparagraphs (i)–(iv) of paragraph (a) of the definition of “estate agent” in section 1 of the Act;
- (e) **“estate agent”** means a person defined in section 1 of the Act, including a candidate estate agent;
- (f) **“franchise”** means an agreement, arrangement or understanding between a franchisor and a franchisee estate agent in terms of which the latter is entitled or required to operate under a trade name which is owned by, or which is associated with the business of, the franchisor or any other person;
- (g) **“immovable property”** means immovable property as defined in section 1 of the Act;
- (h) **“mandate”** means an instruction or an authority given to, and accepted by, estate agent to render an estate agency service;
- (i) **“sole mandate”** means a mandate incorporating an undertaking on the part of the person giving the mandate, not to confer a similar mandate on another estate agent before the expiry of a determined or determinable period;
- (j) **“the Act”** means the Estate Agents Act, 1976 (Act No. 112 of 1976).

2. General duty to protect the public's interest

In terms of estate agents' general duty to members of the public and other persons or bodies, an estate agent—

- 2.1 shall not in or pursuant to the conduct of his business do or omit to do any act which is or may be contrary to the integrity of estate agents in general;
- 2.2 shall protect the interests of his client at all times to the best of his ability, with due regard to the interests of all other parties concerned;

BYLAE**1. Woordomskrywings**

In hierdie gedragskode, tensy uit die samehang anders blyk, beteken—

- (a) **“alleenmandaat”** 'n mandaat wat 'n onderneming deur die mandaatgewer inkorporeer om nie 'n soortgelyke mandaat aan 'n ander eiendomsagent voor die verstryking van 'n bepaalde of bepaalde tydperk te gee nie;
- (b) **“die Wet”** die Wet op Eiendomsagente, 1976 (Wet No. 112 van 1976);
- (c) **“eiendomsagent”** 'n persoon omskryf in artikel 1 van die Wet, met inbegrip van 'n kandidaat-eiendomsagent;
- (d) **“eiendomsagente-diens”** enige diens waarna verwys word in subparagrafe (i)–(iv) van paragraaf (a) van die omskrywing van “eiendomsagent” in artikel 1 van die Wet;
- (e) **“kandidaat-eiendomsagent”** 'n persoon waarna verwys word in paragraaf c (ii) van die omskrywing van “eiendomsagent” in artikel 1 van die Wet wat, onderworpe aan die bepalings van Goewermentskennisgewing No. R. 1469 van 29 Junie 1990, vrygestel is van die standaard van opleiding soos voorgeskryf deur Goewermentskennisgewing No. R. 1409 van 1 Julie 1983;
- (f) **“kliënt”** 'n persoon wat aan 'n eiendomsagent 'n mandaat gegee het, met dien verstande dat indien 'n eiendomsagent botsende mandate ten opsigte van 'n bepaalde onroerende eiendom het, word die persoon wie se mandaat eerste deur die eiendomsagent aanvaar is, as die kliënt beskou;
- (g) **“konsessie”** 'n ooreenkoms, reëling of verstandhouding tussen 'n konsessie-gewer en 'n konsessie-ontvanger eiendomsagent waar kragtens laasgenoemde geregtig is of vereis word om sake te doen onder 'n handelsnaam wat besit word deur, of geassosieer word met die besigheid van, die konsessie-gewer of enige ander persoon;
- (h) **“mandaat”** 'n opdrag of volmag wat aan 'n eiendomsagent gegee en deur hom aanvaar is om 'n eiendomsagente-diens te lewer;
- (i) **“onroerende goed”** onroerende goed soos omskryf in artikel 1 van die Wet;
- (j) **“raad”** die Raad vir Eiendomsagente.

2. Algemene verpligting om die publiek se belange te beskerm

Uit hoofde van eiendomsagente se algemene plig teenoor lede van die publiek en ander persone of instansies—

- 2.1 mag geen eiendomsagent in of voortspruitend uit die dryf van sy besigheid 'n handeling verrig of versuim om 'n handeling te verrig wat die integriteit van eiendomsagente in die algemeen skaad of kan skaad nie;
- 2.2 moet 'n eiendomsagent die belange van sy kliënt te alle tye na die beste van sy vermoë beskerm, met die nodige inagneming van die belange van alle ander betrokke partye;

2.3 shall not in his capacity as an estate agent wilfully or negligently fail to perform any work or duties with such degree of care and skill as might reasonably be expected of an estate agent;

2.4 shall comply with both the Act and the regulations promulgated thereunder;

2.5 shall not through the medium of a company, close corporation or third party, or by using such company, close corporation or third party, or by using such company, close corporation or third party as a front or nominee do anything which would not be permissible for him to do if he were operating as an estate agent;

2.6 shall not deny equal services to any person for reasons or race, creed, sex, or country of national origin;

2.7 shall not discriminate against a prospective purchaser of immovable property on the grounds that such purchaser will not, or is unlikely to, make use of financial assistance made available by any specific person or financial institution and which the estate agent offers to arrange on his behalf.

3. Mandates

No estate agent shall—

3.1 offer, purport or attempt to offer any immovable property for sale or to let or negotiate in connection therewith or canvass or undertake or offer to canvass a purchaser or lessee therefor, unless he has been given a mandate to do so by the seller or lessor of the property, or his duly authorised agent;

3.2 on behalf of a prospective purchaser or lessee, offer, purport or attempt to offer to purchase or lease any immovable property or negotiate in connection therewith or canvass, or undertake or offer to canvass a seller or lessor therefor, unless he has been given a mandate to do so by such prospective purchaser or lessee, as the case may be, or his duly authorised agent;

3.3 accept a sole mandate, or the extension of the period of an existing sole mandate, unless—

3.3.1 all the terms of such mandate (or extension, as the case may be) are in writing and signed by the client;

3.3.2 the expiry date of the mandate (or extension, as the case may be), which shall be expressed as a calendar date, is specifically recorded in the written sole mandate (or extension, as the case may be);

3.4 accept a sole mandate which contains a provision conferring upon him—

3.4.1 an option to extend the sole mandate for a certain period after expiry of the sole mandate; or

2.3 mag geen eiendomsagent in sy hoedanigheid as 'n eiendomsagent opsetlik of nalatig versuim om enige werk te verrig of verpligtinge uit te voer met sodanige sorg en vaardigheid as wat redelikerwys van 'n eiendomsagent verwag kan word nie;

2.4 moet 'n eiendomsagent voldoen aan sowel die Wet en die regulasies daarkragtens uitgevaardig;

2.5 mag geen eiendomsagent deur middel van 'n maatskappy, beslote korporasie of 'n derde party, of deur die gebruikmaking van sodanige maatskappy, beslote korporasie of derde party as 'n front of genomineerde, enigiets doen wat nie vir hom toelaatbaar sou gewees het om te doen indien hy as 'n eiendomsagent sake sou gedoen het nie;

2.6 mag geen eiendomsagent sy gelykwaardige diens weier aan enige persoon op grond van ras, geloof, geslag of land van herkoms nie;

2.7 mag geen eiendomsagent teen 'n voornemende koper van onroerende goed diskrimineer op grond daarvan dat sodanige koper nie, of waarskynlik nie, gebruik sal maak van die finansiële bystand wat beskikbaar gestel word deur enige spesifieke persoon of finansiële instelling en wat die eiendomsagent aanbied om namens hom te reël nie.

3. Mandate

Geen eiendomsagent mag—

3.1 enige onroerende goed te koop of te huur aanbied of voorgee of poog om dit aldus aan te bied, of in verband daarmee onderhandel, of 'n koper of huurder daarvoor werf of onderneem of aanbied om 'n koper of huurder daarvoor te werf, nie, tensy hy 'n mandaat om dit te doen van die verkoper of verhuurder van die onroerende goed, of sy gevolgmagtigde verteenwoordiger, ontvang het;

3.2 namens 'n voornemende koper of huurder aanbied om enige onroerende goed te koop of te huur, of voorgee of poog om sodanige aanbod te maak, of in verband daarmee onderhandel of 'n verkoper of verhuurder daarvoor werf of onderneem of aanbied om 'n verkoper of huurder daarvoor te werk, nie, tensy sodanige voornemende koper of huurder, na gelang van die geval, of sy gevolgmagtigde verteenwoordiger, aan hom 'n mandaat gegee het om dit te doen;

3.3 'n alleenmandaat, of die verlenging van die tydperk van 'n bestaande alleenmandaat, aanvaar nie, tensy—

3.3.1 al die bepalings van sodanige mandaat (of verlenging, na gelang van die geval) op skrif gestel en deur die kliënt onderteken is;

3.3.2 die vervaldatum van die mandaat (of verlenging, na gelang van die geval), welke datum as 'n kalenderdatum uitgedruk moet word, spesifiek in die geskrewe alleenmandaat (of verlenging, na gelang van die geval) gemeld word;

3.4 'n alleenmandaat aanvaar wat 'n bepaling bevat waarkragtens hy—

3.4.1 'n opsie het om die alleenmandaat vir 'n bepaalde tydperk na verstryking van die alleenmandaat, te verleng nie; of

3.4.2 a mandate to continue to render the same estate agency service referred to in the sole mandate, after expiry of the sole mandate,

unless—

(S)

(aa) the client has prior to his signature of the sole mandate expressly consented in a written document executed independently of the said sole mandate, to the inclusion of such provision or provisions (as the case may be); and

(bb) such document contains an explanation of the reasons for and implications of the inclusion of such provision; and

(cc) such document is signed by both the client and the estate agent in question;

3.5 accept a sole mandate which also confers upon him a power of attorney to act on behalf of the person conferring the mandate, unless the intention and effect of such power of attorney is fully explained in the document embodying the sole mandate;

3.6 include, or cause to be included, or accept the benefit of, any clause in a contract of sale or lease of immovable property negotiated by him, whereby a sole mandate is directly or indirectly conferred upon him to sell or let the said immovable property at any time after the conclusion of the said contract;

3.7 accept any mandate or instructions for work in respect of immovable property if his interest therein would compete with his obligations towards an existing client in respect of the same immovable property without first disclosing such interest in writing to such client;

3.8 knowingly or negligently make a material misrepresentation concerning the likely market value or rental income of immovable property to a seller or lessor thereof, in order to obtain a mandate in respect of such property;

3.9 accept a mandate in respect of any immovable property if the performance of the mandate requires specialised skill or knowledge falling outside his field of competence, unless he will in the performance of the mandate be assisted by a person who has the required skill or knowledge and this fact is disclosed in writing to the client;

3.10 accept a sole mandate to sell or let immovable property, unless he has explained in writing to the client—

3.10.1 the legal implications should the client during the currency of the sole mandate or thereafter sell or let the property without the assistance of the estate agent, or through the intervention of another estate agent; and

3.4.2 'n mandaat het om voort te gaan om dieselfde eiendomsagente diens wat in die alleenmandaat genoem word, na verstryking van die alleenmandaat te lewer nie,

tensy—

(aa) die kliënt voordat hy die alleenmandaat onderteken het, uitdruklik in 'n skriftelike dokument wat onafhanklik van die genoemde alleenmandaat opgestel is, ingestem het tot die insluiting van sodanige bepalings of bepalings (na gelang van die geval); en

(bb) sodanige dokument 'n verduideliking bevat van die redes vir en implikasies van die insluiting van sodanige bepaling; en

(cc) sodanige dokument deur beide die kliënt en die betrokke eiendomsagent onderteken is;

3.5 'n alleenmandaat aanvaar wat ook 'n volmag aan hom verleen om namens die mandaatgewer op te tree nie, tensy die bedoeling en uitwerking van sodanige volmag volledig in die dokument wat die alleenmandaat beliggaam, verduidelik word;

3.6 'n bepaling in 'n koop- of huurkontrak wat hy onderhandel het, insluit of laat insluit, of die voordeel daarvan aanvaar, ingevolge waarvan 'n alleenmandaat direk of indirek aan hom verleen word om genoemde onroerende goed te enige tyd na die sluiting van die genoemde kontrak te verkoop of te verhuur nie;

3.7 'n mandaat of opdragte vir werk ten opsigte van onroerende goed aanvaar indien sy belang daarin meeding met sy verpligtinge teenoor 'n bestaande kliënt in verband met dieselfde onroerende goed, sonder om eers sodanige belang skriftelik aan sodanige kliënt te openbaar nie;

3.8 opsetlik of nalatig 'n wesenlike wanvoorstelling betreffende die waarskynlike markwaarde of huurinkomste van onroerende goed aan 'n verkoper of verhuurder daarvan maak ten einde 'n mandaat ten opsigte van sodanige onroerende goed te verkry nie;

3.9 'n mandaat ten opsigte van onroerende goed aanvaar indien die uitvoering van die mandaat gespesialiseerde vaardigheid of kennis vereis wat buite sy sfeer van bevoegdheid val nie, tensy hy in die uitvoering van die mandaat bygestaan sal word deur 'n persoon wat die nodige vaardigheid of kennis het en sodanige feit skriftelik aan die kliënt openbaar word;

3.10 'n alleenmandaat om onroerende goed te verkoop of te verhuur aanvaar nie, tensy hy skriftelik aan die kliënt verduidelik het—

3.10.1 wat die regsimplikasies sal wees indien die kliënt gedurende die tydperk van die alleenmandaat, of daarna, die onroerende goed sonder die bystand van die eiendomsagent, of deur die tussenkoms van 'n ander eiendomsagent, verkoop of verhuur; en

3.10.2 what specific obligations in respect of the marketing of the property will be assumed by the estate agent in his endeavour to perform the mandate:

Provided that such explanations, if contained in a standard pre-printed or typed sole mandate document, shall be in lettering not smaller than that generally used in the remainder of the document.

4. Duty to disclose

4.1 An estate agent shall—

4.1.1 convey to a purchaser or lessee or a prospective purchaser or lessee of immovable property in respect of which a mandate has been given to him to sell, let, buy or hire, all facts concerning such property as are, or should reasonably in the circumstances be, within his personal knowledge and which are or could be material to a prospective purchaser or lessee thereof;

4.1.2 if he conducts his business in terms of an franchise, disclose clearly and unambiguously in all his correspondence, circulars, advertisements and other written documentation that he operates in terms of a franchise and state thereon his name and the name of the franchisor;

4.1.3 if he conducts his business under a trade name or style other than his own name, clearly disclose his full name in all correspondence, circulars and other written documentation.

4.1.4 not perform or attempt to perform any mandate in respect of a particular property if a current prior mandate, which conflicts with the aforesaid mandate, has been accepted by him, unless he has disclosed to the person who has given the later mandate the existence of such prior mandate, and the fact that he will not be the estate agent's client in respect of that property.

4.2 No estate agent shall purchase directly or indirectly for himself, or acquire any interest in, or conclude a lease in respect of, any immovable property in respect of which he has a mandate, without the full knowledge and consent of the person who conferred the mandate, or sell or let his own immovable property or any immovable property in which he has any direct or indirect interest, to any prospective purchaser or lessee who has retained his services, without that purchaser or lessee having full knowledge of his ownership of, or interest in, such immovable property.

5. *Duty not to make misrepresentations or false statements or to use harmful marketing techniques*

No estate agent shall—

5.1 in his capacity as an estate agent publish or cause to be published any advertisement which could create the impression that it was published by the owner, seller or lessor of immovable property, or by a prospective purchaser or lessee of immovable property;

3.10.2 watter spesifieke verpligtinge ten aansien van die bemarking van die onroerende goed deur die eiendomsagent aanvaar sal word in sy strewende om die mandaat uit te voer:

Met dien verstande dat sodanige verduidelikings, indien dit vervat is in 'n standaard voorafgedrukte of getikte alleenmandaat-dokument, nie van 'n kleiner lettergrootte mag wees as wat algemeen in die res van die dokument gebruik word nie.

4. *Verpligting om te openbaar*

4.1 'n Eiendomsagent—

4.1.1 moet aan 'n koper of huurder of voornemende koper of huurder van onroerende goed ten opsigte waarvan 'n mandaat aan hom gegee is om dit te verkoop, verhuur, koop of huur, alle feite met betrekking tot sodanige onroerende goed wat binne sy persoonlike kennis val, of in die omstandighede redelikerwys binne sy kennis behoort te val, en wat vir 'n voornemende koper of huurder daarvan wesenlik is of mag wees, meedeel;

4.1.2 moet indien hy sy besigheid op 'n konsessiegrondslag dryf, duidelik en ondubbelsinnig in al sy korrespondensie, omsendskrywes, advertensies en ander geskrewe dokumente openbaar dat hy kragtens 'n konsessie handel en sy naam sowel as die naam van die konsessiegewer daarin vermeld;

4.1.3 moet indien hy sy besigheid onder 'n handelsnaam of styl anders as sy eie naam dryf, sy volle naam duidelik in alle korrespondensie, omsendskrywes en ander geskrewe dokumente vermeld.

4.1.4 mag nie 'n mandaat ten opsigte van 'n bepaalde onroerende eiendom uitvoer of poog om dit uit te voer indien 'n geldende mandaat wat met voorgenoemde mandaat bots reeds voorheen deur hom aanvaar is nie, tensy die bestaan van sodanige vorige mandaat, en die feit dat hy nie die eiendomsagent se kliënt ten opsigte van daardie eiendom sal wees nie, aan die persoon wat die latere mandaat gegee het, openbaar word.

4.2 Geen eiendomsagent mag onroerende goed ten aansien waarvan hy 'n mandaat het, direk of indirek vir homself koop, of enige belang daarin verkry, of 'n huurkontrak ten opsigte daarvan aangaan, sonder die volle medewete en toestemming van die mandaatgewer nie, of sy eie onroerende goed of enige onroerende goed waarin hy enige direkte of indirekte belang het, aan enige voornemende koper of huurder wat sy dienste bekom het, verkoop of verhuur sonder dat daardie koper of huurder volledig kennis dra van sy eiendomsreg of belang in sodanige onroerende goed nie.

5. *Verpligting om nie wanvoorstellings of valse verklarings te maak of om skadelike bemarkingstegnieke te gebruik nie*

Geen eiendomsagent mag—

5.1 in sy hoedanigheid as eiendomsagent enige advertensie publiseer of laat publiseer wat die indruk mag skep dat dit deur die eienaar, verkoper of verhuurder van onroerende goed, of deur 'n voornemende koper of huurder van onroerende goed, gepubliseer is nie;

5.2 wilfully or negligently, in relation to his activities as an estate agent, prepare, make or assist any other person to prepare or make any false statement, whether orally or in writing, or sign any false statement in relation thereto knowing it to be false, or knowingly or recklessly prepare or maintain any false books of account or other records;

5.3 claim to be an expert or to have specialised knowledge in respect of any estate agency service if, in fact, he is not such an expert or does not have such special knowledge;

5.4 advertise or otherwise market immovable property in respect of which he has been given a mandate to sell or let, at a price or rental other than that agreed upon with the seller or lessor of the property;

5.5 without derogating from the generality of the foregoing—

5.5.1 wilfully or negligently mislead or misrepresent in regard to any matter pertaining to the immovable property in respect of which he has a mandate;

5.5.2 use any harmful or misleading marketing technique or method to influence any person to confer upon him a mandate to render any estate agency service or to sell, purchase, let or hire immovable property, having regard to the general experience which such person has concerning property transactions and the circumstances surrounding the transaction or proposed transaction;

5.6 use any firm or trading name in respect of his business if such name may give rise to confusion on the part of the public in respect of the nature of the business carried on by him;

5.7 inform a seller or purchaser, or prospective seller or purchaser, of immovable property in respect of which he has been given a mandate to sell or purchase, that he has obtained an offer in respect of the property from a purchaser or the seller (as the case may be), unless such offer—

5.7.1 is in writing; and

5.7.2 has been signed by the offeror; and

5.7.3 is to the knowledge of the estate agent concerned, a *bona fide* offer;

5.8 affix any board or notice to immovable property indicating that such property is for sale or hire or has been sold or let, unless—

5.8.1 the seller or lessor (as the case may be) has given his written consent to do so; and

5.8.2 the estate agent concerned in fact has a mandate to sell or let the property, or in fact has sold or let the property, as the case may be.

5.2 opsetlik of nalatig, in verband met sy bedrywighede as 'n eiendomsagent, enige valse verklaring voorberei of maak of enige ander persoon bystaan om dit voor te berei of te maak nie, hetsy mondeling of skriftelik, of 'n valse verklaring in verband daarmee onderteken wetende dat dit vals is, of opsetlik of op 'n roekelose wyse enige valse boeke of rekeninge of ander rekord voorberei of hou nie;

5.3 daarop aanspraak maak dat hy 'n deskundige op die gebied van enige eiendomsagentediens is of gespesialiseerde kennis ten aansien daarvan het nie, indien hy inderwaarheid nie sodanige deskundige is of sodanige gespesialiseerde kennis het nie;

5.4 onroerende goed ten aansien waarvan hy 'n mandaat het om dit te verkoop of te verhuur, teen 'n ander prys of huurgeld as waarvoor met die verkoper of verhuurder van die onroerende goed ooreengekom is, adverteer of andersins bemark nie;

5.5 sonder om afbreuk te doen aan die algemeenheid van die voorafgaande—

5.5.1 opsetlik of nalatig mislei of 'n wanvoorstelling maak in verband met enige aangeleentheid wat betrekking het op onroerende goed ten opsigte waarvan hy 'n mandaat het nie;

5.5.2 enige skadelike of misleidende bemarkingstechniek of -metode gebruik ten einde 'n persoon te beïnvloed om aan hom 'n mandaat te gee om enige eiendomsagentediens te lewer, of om onroerende goed te verkoop, koop, verhuur of huur nie, met inagneming van die algemene ondervinding wat sodanige persoon van eiendomstransaksies het en die omstandighede onderliggend aan die transaksie of beoogde transaksie;

5.6 enige firma- of handelsnaam ten opsigte van sy besigheid as 'n eiendomsagent gebruik nie, indien sodanige naam tot verwarring aan die kant van die publiek aanleiding kan gee aangaande die aard van die besigheid wat hy bedryf;

5.7 'n verkoper of koper, of voornemende verkoper of koper van onroerende goed ten aansien waarvan hy 'n mandaat het om dit te verkoop of te koop, meedeel dat hy 'n aanbod ten opsigte van die onroerende goed van 'n koper of die verkoper (na gelang van die geval) ontvang het nie, tensy sodanige aanbod—

5.7.1 op skrif gestel is; en

5.7.2 deur die aanbieder onderteken is; en

5.7.3 sover dit binne die betrokke eiendomsagent se kennis val, 'n *bona fide* aanbod is;

5.8 enige bord of kennisgewing aan onroerende goed heg wat daarop dui dat sodanige onroerende goed te koop of te huur is of dat dit verkoop of verhuur is nie, tensy—

5.8.1 die verkoper of verhuurder (na gelang van die geval) skriftelike toestemming daartoe verleen het; en

5.8.2 die betrokke eiendomsagent inderwaarheid 'n mandaat het om die onroerende goed te verkoop of te verhuur, of inderwaarheid dit verkoop of verhuur het, na gelang van die geval.

6. Duties in respect of offers and contracts

6.1 No State agent—

6.1.1 who has a mandate to sell or purchase immovable property shall wilfully fail to present or cause to be presented to the seller or purchaser concerned, any offer to purchase or sell such property, received prior to the conclusion of a contract of sale in respect of such property, unless the seller or purchaser (as the case may be) has instructed him expressly not to present such offer;

6.1.2 who has a mandate to sell immovable property, may present competing offers to purchase the property in such a manner as to induce the seller to accept any particular offer without regard to the advantages and/or disadvantages of each offer for the seller;

6.1.3 shall amend any provision of a signed offer, prior to rejection thereof, or a written mandate or any contract of sale or lease, without the knowledge and express consent of the offeror or the parties to the contract, as the case may be.

6.2 An estate agent shall—

6.2.1 explain to every prospective party to any written offer or contract negotiated or procured by him in his capacity as an estate agent, prior to signature thereof by such party, the meaning and consequences of the material provisions of such offer or contract, or, if he is unable to do so, refer such party to a person who can do so;

6.2.2 if he knows that an offer submitted by him as an estate agent to any party has been accepted, or has not been accepted by the expiry date thereof, forthwith notify the offeror of such fact;

6.2.3 without undue delay furnish every contracting party with a copy of an agreement of sale, lease, option or mandate with which he is concerned as an estate agent, provided that the foregoing shall also apply in respect of an offer to purchase or lease if the offeror specifically requests a copy thereof.

7. Prohibition against undue influence

No estate agent shall without good and sufficient cause, directly or indirectly, in any manner whatsoever, solicit, encourage, persuade or influence any party or potential party to a pending or a complete transaction to utilise or refrain from utilising—

7.1 the services of any particular attorney, conveyancer or firm of attorneys;

7.2 the services or financial assistance offered by any financial institution to members of the public in general; or

7.3 the financial assistance offered to such party by any person.

6. Verpligtinge ten opsigte van aanbiedinge en kontrakte

6.1 Geen eiendomsagent—

6.1.1 wat 'n mandaat het om onroerende goed te verkoop of te koop, mag opsetlik nalaat om aan die betrokke verkoper of koper enige aanbod om sodanige onroerende goed te koop of te verkoop en wat voor die sluiting van 'n koopkontrak ten opsigte van die onroerende goed ontvang is, voor te lê of te laat voorlê nie, tensy die verkoper of koper (na gelang van die geval) hom uitdruklik opdrag gegee het om nie sodanige aanbod voor te lê nie;

6.1.2 wat 'n mandaat het om onroerende goed te verkoop, mag mededingende aanbiedinge om die onroerende goed te koop op sodanige wyse voorlê ten einde die verkoper te oorreed om 'n bepaalde aanbod te aanvaar sonder inagneming van die voordele en/of nadele wat elke aanbod vir die verkoper inhou nie;

6.1.3 mag enige bepaling van 'n getekende aanbod, voor afwysing daarvan, of 'n geskrewe mandaat of enige koop- of huurkontrak wysig, sonder die kennis en uitdruklike toestemming van die aanbieder of die partye tot die kontrak, na gelang van die geval, nie.

6.2 'n Eiendomsagent moet—

6.2.1 aan elke voornemende party tot 'n skriftelike aanbod of kontrak wat deur hom as eiendomsagent onderhandel of verkry is, voor ondertekening daarvan deur sodanige party, verduidelik wat die betekenis en gevolge van die wesentliche bepalings van sodanige aanbod of kontrak is, of, indien hy nie in staat is om dit te doen nie, sodanige party na 'n persoon verwys wat dit wel kan doen;

6.2.2 indien hy weet dat 'n aanbod wat deur hom as eiendomsagent aan 'n persoon voorgelê is, aanvaar is, of nie teen die vervaldatum daarvan aanvaar is nie, onverwyld die aanbieder van sodanige feit in kennis stel;

6.2.3 sonder onnodige versuim elke kontrakparty voorsien van 'n afskrif van 'n koop- of huurooreenkoms, opsie of mandaat waarby hy as eiendomsagent betrokke is, met dien verstande dat dieselfde ook ten opsigte van 'n aanbod om te koop of te huur van toepassing is indien die aanbieder spesifiek 'n afskrif daarvan versoek.

7. Verbod op onbehoorlike beïnvloeding

Geen eiendomsagent mag regstreeks of onregstreeks sonder goeie en genoegsame gronde op enige wyse hoegenaamd, enige party of potensiële party tot 'n voltooide of hangende transaksie, werf, aanmoedig, oorhaal of beïnvloed om gebruik te maak of nie gebruik te maak nie van—

7.1 die dienste van 'n bepaalde prokureur, transportbesorger of prokureurfirma;

7.2 die dienste of finansiële bystand wat deur enige finansiële instelling aan lede van die publiek in die algemeen aangebied word; of

7.3 die finansiële bystand wat deur enige persoon aan sodanige party aangebied word, nie.

8. Remuneration

No estate agent shall—

8.1 stipulate for, demand or receive directly or indirectly any remuneration, commission, benefit or gain arising from or connected with any completed, pending or proposed contract of sale or lease which is subject to—

8.1.1 a suspensive condition, until such time as that condition has been fulfilled; or

8.1.2 a resolute condition, during the time that the transaction may fall away as a result of the operation of the said resolute condition:

Provided that the foregoing shall not apply if—

(aa) good cause exists; and

(bb) the party liable for the payment of the remuneration, commission, benefit or gain has expressly consented in a written document executed independently of the contract in question, to such payment at any time, notwithstanding the fact that the said contract is subject to a suspensive or resolute condition, as the case may be; and

(cc) such document contains an explanation of the implications and financial risks for such party of such payment; and

(dd) such document is signed by such party and the estate agent in question;

8.2 convey to his client or any other party to a completed or proposed transaction in which he acted or acts as an estate agent, that he is precluded by law from charging less than a particular commission or fee, or that such commission or fee is prescribed by law, the board or any institute or association of estate agents or any other body;

8.3 introduce a prospective purchaser or lessee to any immovable property or to the seller or lessor thereof, if he knows, or has reason to believe, that such person has already been introduced to such property or the seller or lessor thereof by another estate agent and that there is a likelihood that his client may have to pay commission to such other, or to more than one, estate agent should the sale or lease be concluded through his intervention: Provided that the foregoing shall not apply if the estate agent has informed his client of such likelihood and obtained his written consent to introduce such party to the property or the seller or lessor thereof;

8.4 include, or cause to be included, or accept the benefit of, any clause in a mandate or in a contract of sale or lease of immovable property, providing for payment to him by the seller or lessor of immovable property, of any remuneration, commis-

8. Vergoeding

Geen eiendomsagent mag—

8.1 direk of indirek enige vergoeding, kommissie, voordeel of wins beding, eis of ontvang wat voortspruit uit of in verband staan met enige voltooide, hangende of beoogde transaksie wat onderworpe is aan—

8.1.1 'n opskortende voorwaarde, totdat sodanige voorwaarde vervul is nie; of

8.1.2 'n ontbindende voorwaarde, gedurende die tydperk waarbinne die transaksie kan verval as gevolg van die werking van genoemde ontbindende voorwaarde nie:

Met dien verstande dat die voorgaande nie van toepassing sal wees nie indien—

(aa) gegronde redes daarvoor bestaan; en

(bb) die partye aanspreeklik vir die betaling van die vergoeding, kommissie, voordeel of wins uitdruklik in 'n skriftelike dokument wat onafhanklik van die betrokke kontrak opgestel is, ingestem het tot sodanige betaling op enige tydstip, nieteenstaande die feit dat die genoemde kontrak onderworpe is aan 'n opskortende of ontbindende voorwaarde, na gelang van die geval; en

(cc) sodanige dokument 'n verduideliking bevat van die implikasies en finansiële risiko's van sodanige betaling vir sodanige party; en

(dd) sodanige dokument deur sodanige party en die betrokke eiendomsagent onderteken is;

8.2 aan sy kliënt of enige ander party tot 'n voltooide of beoogde transaksie ten opsigte waarvan hy as 'n eiendomsagent opgetree het of optree, te kenne gee dat hy regtens belet word om minder as 'n bepaalde kommissie of fooi te hef, of dat sodanige kommissie of fooi deur die reg, die raad of enige instituut of assosiasie van eiendomsagente of enige ander liggaam, voorgeskryf word;

8.3 'n voornemende koper of huurder aan onroerende goed of aan die verkoper of verhuurder daarvan, voorstel nie, indien hy weet, of rede het om te glo, dat sodanige persoon alreeds deur 'n ander eiendomsagent aan sodanige onroerende goed of die verkoper of verhuurder daarvan voorgestel is, en dat daar 'n moontlikheid bestaan dat sy kliënt moontlik aan sodanige ander, of aan meer as een, eiendomsagent kommissie sal moet betaal indien die koop of huurkontrak deur sy tussenkoms gesluit word: Met dien verstande dat die voorgaande nie sal geld nie indien die eiendomsagent sy kliënt oor sodanige moontlikheid ingelig het en sy skriftelike toestemming ontvang het om sodanige party aan die onroerende goed of die verkoper of verhuurder daarvan voor te stel;

8.4 enige bepaling in 'n mandaat of in 'n koop- of huurkontrak van onroerende goed insluit, of laat insluit, of die voordeel van enige sodanige bepaling aanvaar, wat voorsiening maak vir betaling aan hom, deur die verkoper of verhuurder van onroerende

sion, benefit or gain arising from or connected with a contract of sale or lease, regardless of the fact whether the purchaser or lessee is financially able to fulfill his obligations in terms of the said contract: Provided that the foregoing shall not apply if—

(aa) good cause exists; and

(bb) the seller or lessor has, prior to his signature of the contract or mandate (as the case may be) consented in writing in a document executed independently of the said mandate and contract, to such payment; and

(cc) such document contains an explanation of the implications and financial risks for the seller or lessor of such payment; and

(dd) such document is signed by both the estate agent and the seller or lessor;

8.5 include, or cause to be included, or accept the benefit of, any clause in a contract of sale or lease of immovable property negotiated by him, entitling him to deduct from any money entrusted to him in terms of the contract, any remuneration, commission, benefit or gain arising from or connected with such contract: Provided that the foregoing shall not be so construed so as to prohibit an estate agent from making such deduction when such money is actually paid over by him to the party entitled thereto and such party is in terms of the said contract liable for the payment of such remuneration, commission, benefit or gain.

9. Trust money and interest

An estate agent—

9.1 shall not solicit or influence any person entitled to trust funds in the agent's possession or under his control to make over or pay to the estate agent directly or indirectly any interest on moneys deposited or invested in terms of section 32 (1) or 32 (2) (a) of the Act;

9.2 shall, before he receives any money in trust in respect of a contract of sale or lease, disclose to the parties concerned that unless they agree in writing to whom interest earned on such money must be paid, the interest shall, in terms of section 32 (2) (c) of the Act, accrue to the Estate Agents Fidelity Fund;

9.3 shall, if any money is invested by him pursuant to section 32 (2) (a) of the Act or pursuant to an instruction by the party entitled to the interest on money held in trust by the estate agent—

9.3.1 invest such money at the best interest rate available in the circumstances at the bank or building society where he normally keeps his trust account or accounts, and

goed, van enige vergoeding, kommissie, voordeel of wins wat uit 'n koop- of huurkontrak voortspruit of daarmee verband hou, ongeag die feit of die betrokke koper of huurder finansiëel in staat is om sy verpligtinge ingevolge genoemde kontrak na te kom nie: Met dien verstande dat die voorafgaande nie van toepassing sal wees nie indien—

(aa) gegronde redes daarvoor bestaan; en

(bb) die verkoper of verhuurder voor sy ondertekening van die kontrak of mandaat (na gelang van die geval) skriftelik in 'n dokument wat onafhanklik van die betrokke mandaat en kontrak opgestel is, tot sodanige betaling ingestem het; en

(cc) sodanige dokument 'n verduideliking bevat van die implikasies en finansiële risiko's van sodanige betaling vir sodanige verkoper of verhuurder; en

(dd) sodanige dokument deur beide die eiendomsagent en sodanige verkoper of verhuurder onderteken is;

8.5 enige bepaling in 'n koop- of huurkontrak van onroerende goed wat deur hom onderhandel is, insluit, of laat insluit, of die voordeel van enige sodanige bepaling aanvaar, waardeur hy geregtig is om van enige geld wat ingevolge die kontrak aan hom toevertrou is, enige vergoeding, kommissie, voordeel of wins wat uit sodanige kontrak voortvloei of daarmee verband hou, af te trek nie: Met dien verstande dat die voorgaande nie so uitgelê moet word dat dit die eiendomsagent belet om sodanige aftrekking te maak wanneer sodanige geld daadwerklik deur hom aan die party wat daarop geregtig is, oorbetaal word, en sodanige party ingevolge die genoemde kontrak vir die betaling van sodanige vergoeding, kommissie, voordeel of wins aanspreeklik is nie.

9. Trustgeld en rente

'n Eiendomsagent—

9.1 mag nie enige persoon wat geregtig is op trustfondse in die eiendomsagent se besit of onder sy beheer versoek of beïnvloed om direk of indirek enige rente op geld gedeponeer of belê ingevolge artikel 32 (1) of 32 (2) (a) van die Wet aan die eiendomsagent oor te maak of te betaal nie;

9.2 moet, voordat hy geld ten opsigte van 'n koop- of huurkontrak in trust ontvang, aan die betrokke partye bekend maak dat tensy hulle skriftelik ooreenkom aan wie die rente wat op sodanige geld verdien word, betaal moet word, die rente ingevolge artikel 32 (2) (c) van die Wet die Eiendomsagentsgetrouheidsfonds toeval;

9.3 moet, indien enige geld deur hom belê word uit hoofde van artikel 32 (2) (a) van die Wet of ten uitvoer van 'n opdrag gegee deur die party wat geregtig is op die rente op die geld wat deur die eiendomsagent in trust gehou word—

9.3.1 sodanige geld teen die beste rentekoers belê wat in die omstandighede beskikbaar is by die bank of bouvereniging waar hy normaalweg sy trustrekening of -rekening hou, en

9.3.2 pay the full amount of the interest which accrued on the investment to the party entitled to such interest, or the board, as the case may be, subject to any written agreement in this regard between him and such party;

9.4 shall not include, or cause to be included, or accept the benefit of, any clause in a contract of sale of immovable property negotiated by him, providing for payment to the seller, prior to registration of transfer of the property in the purchaser's name, of any portion of the purchase price entrusted to the estate agent by the purchaser: Provided that the foregoing shall not apply if—

(aa) good cause exists; and

(bb) the purchaser has prior to his signature of the contract in question, consented in writing in a document executed independently of the said contract, to such payment; and

(cc) such document contains an explanation of the implications and financial risks of such payment for the purchaser; and

(dd) such document is signed by both the seller and the purchaser and the estate agent in question.

10. Confidentiality

No estate agent shall, without just cause, divulge to any third party any confidential information obtained by him concerning the business affairs, trade secrets or technical methods or processes of a client or any party to a transaction in respect of which he acted as an estate agent.

11. Vicarious responsibility

Every estate agent who is the sole proprietor of an estate agency business or a partner in a partnership or a director of a company or a member of a close corporation contemplated in paragraph (b) of the definition of "estate agent" in section 1 of the Act carrying on the business of an estate agent, shall be held responsible for any contravention of or failure to comply with this code of conduct by any other partner, director, or member or by any estate agent in the service of such sole proprietorship, partnership, company or close corporation, unless he has prior to such contravention or failure to comply taken all reasonable steps to prevent the same and could not in the circumstances have prevented such contravention or failure to comply.

12. Government Notices Nos. R. 1799 of 29 August 1986 and R. 2106 of 3 October 1986 are hereby repealed.

13. This notice will come into operation on 1 April 1993.

9.3.2 die volle bedrag van die rente wat op die belegging opgeloopt het, aan die party wat geregtig is op sodanige rente, of die raad, na gelang van die geval, betaal, onderworpe aan enige skriftelike ooreenkoms in hierdie verband tussen hom en sodanige party;

9.4 mag nie enige bepaling in 'n koopkontrak van onroerende goed wat deur hom onderhandel is, insluit, of laat insluit, of die voordeel van enige sodanige bepaling aanvaar, wat voorsiening maak vir betaling aan die verkoper, voor registrasie van oordrag van die eiendom in die koper se naam, van enige gedeelte van die koopprys wat deur die koper aan die eiendomsagent toevertrou is nie: Met dien verstande dat die voorafgaande nie sal geld nie indien—

(aa) gegronde redes daarvoor bestaan; en

(bb) die koper voor sy ondertekening van die betrokke kontrak, skriftelik in 'n dokument wat onafhanklik van genoemde kontrak opgestel is, tot sodanige betaling ingestem het; en

(cc) sodanige dokument 'n verduideliking bevat van die implikasies en finansiële risiko's van sodanige betaling vir die koper; en

(dd) sodanige dokument deur beide die verkoper en die koper en die betrokke eiendomsagent onderteken is.

10. Vertroulikheid

Geen eiendomsagent mag sonder goeie gronde aan enige derde party enige vertoulike inligting wat deur hom verkry is rakende sake-aangeleenthede, bedryfsgeheime of tegniese metodes of prosesse van 'n kliënt of enige party tot 'n transaksie ten opsigte waarvan hy as 'n eiendomsagent opgetree het, openbaar nie.

11. Middellike verantwoordelikheid

Elke eiendomsagent wat die alleeneienaar is van 'n eiendomsagentskap of 'n vennoot in 'n vennootskap of 'n direkteur van 'n maatskappy of 'n lid is van 'n beslote korporasie bedoel in paragraaf (b) van die omskrywing van "eiendomsagent" in artikel 1 van die Wet wat sake doen as 'n eiendomsagent, sal verantwoordelik gehou word vir enige oortreding van of versuim om te voldoen aan hierdie gedragskode deur enige ander vennoot, direkteur of lid of deur enige persoon in diens van sodanige alleeneienaar-eiendomsagentskap, vennootskap, maatskappy of beslote korporasie, tensy hy voor sodanige oortreding of versuim alle redelike stappe gedoen het om dit te verhoed, en nie onder die omstandighede sodanige oortreding of versuim kon verhoed nie.

12. Goewermentskennisgewings Nos. R. 1799 van 29 Augustus 1986 en R. 2106 van 3 Oktober 1986 word hierby ingetrek.

13. Hierdie kennisgewing tree in werking op 1 April 1993.

Budget deficit 'easily financed'

Institutions set to free up R35bn in 1993

8/10/92 28/12/92
MASSIVE cash flows to institutions have emerged virtually unscathed from the recession, with analysts estimating the amount of new cash available for investment next year at about R35bn-R40bn.

While the amount would be almost unchanged from this year, analysts said the flow of contractual savings was still big enough easily to finance even a huge Budget deficit next year without putting significant upward pressure on interest rates.

Even the combined effect of the recession and strong demand for finance from the public sector would not temper the "hothouse" effect at work in SA's closed financial markets.

Southern Life investments GM Paul Beachy-Head said the recession had put a damper on the growth in funds flowing to the institutions. Surrenders and lapses of policies had become more common, while less new business had been sold. Pension funds had been affected by retrenchment payouts. On a net basis, benefits paid had gone up. He estimated the flow of contractual savings to institutions next year at about R35bn.

The state pension funds are not included in the flow of funds to private institutions and could add up to another R20bn to the new cash available for investment. Virtually the entire amount is usually invested in government stock. Beachy-Head noted the state pension funds had also been affected by retrenchments.

"Nevertheless, government will easily finance its deficit next year," he predicted, although he saw the possibility of higher

long-term interest rates depending on the amount government needed to borrow.

Syfrets Managed Assets spokesman Leon Campher's estimates were at the lower end of the range of predictions. He saw R30bn-R34bn as possible, noting that the percentage of new premium flow to benefits paid out was increasing.

He said the flow of state funds to the Public Investment Commissioners could add another R17bn to the finance available for investment. But Campher agreed a big deficit would be "quite easily financed" from the flow of contractual savings.

An analyst at a stockbroking firm put the flow of funds to institutions at about R38bn. He said contractual savings had been affected adversely by the recession, while government's deficit had been rising rapidly — a situation which would have to turn around if strong upward pressure on interest rates were to be avoided.

Nevertheless he did not expect the public sector's borrowing requirements to have a significant effect on the financial markets.

Estimates of the Budget deficit next year vary between R20bn-R30bn, depending on the extent to which government wants to increase revenue by raising taxes. Finance Minister Derek Keys has said the 1992/98 deficit will reach R28bn.

If the deficit is reduced to R25bn, it would still be more than 6% of GDP. Economist Louis Geldenhuys of Senekal, Mouton & Kitshoff said this would be possible with a 3% real decline in spending and no compensation for fiscal drag.

GRETA STEYN

FINANCE - LABOUR

1993

Bank employment levels rise

Finance jobs buck trend of tough times

BIOMY 11/1/93

59

GRETA STEYN

THE number of people employed in financial services rose by more than 5 000 last year at a time when recession caused hundreds of thousands of employees in other sectors to lose their jobs.

Latest Central Statistical Service figures show that the number of people in full-time employment in banks, building societies and insurance companies rose by 5 337 in the year to end-September 1992.

Over the same period, more than 47 000 jobs were lost in the manufacturing industry.

Financial services did not feel the effects of the recession to the same extent as the rest of the economy.

In the national accounts, finance made a positive contribution to real GDP in the third quarter last year while manufacturing's contribution fell by almost 2,5% in real terms.

But the rise in employment in financial services came at a time when some major banks, notably Absa, were conducting rationalisation exercises.

In spite of the rationalisation efforts in the industry, bank and building society staffs grew by more than 3 000 over the period.

First National Bank was one of the institutions whose staff numbers grew last year, the increase coming after two years of declining staff numbers that reflected a rationalisation drive.

A spokesman said there had been a small increase in the number of people

employed last year, as there had been "quite an expansion in business".

Also increasing its staff numbers was the Standard Bank group. A spokesman said the increase had exceeded the 2,8% rise for the financial services industry as a whole.

He said staff numbers were not only related to the business cycle but to longer-term strategies undertaken by the bank.

Absa and Nedcor said their staff numbers had declined in line with their rationalisation plans.

An analyst said the smaller banks had done well during the recession and would not have needed to shed staff.

Markets in which banks traded did well last year, with capital market volumes surging and derivatives taking off.

Seifsa economist Michael MacDonald said the growth in the services industry, relative to the rest of the economy, was a global phenomenon in the industrialised world.

He added that part of the reason for the manufacturing sector shedding jobs was that it was becoming more capital intensive.

The growth of the financial sector could not take up the slack as it was highly automated.

But the financial sector would help create jobs as a result of the drive to improve the provision of banking services to wider sections of the community, MacDonald said.

'Bank is racist' - fired employee

Sowetan 13/1/93

By Joe Mdhlela
Consumer Reporter

FOR YOUNG JABULANI Sithole, former employee of the bank that claims to be "looking ahead" of time, the slogan is hollow. The Standard Bank Alrode branch dismissed him three weeks ago, alleging he had defrauded them of R18 000.

This was in spite of the fact that an Alberton magistrate had withdrawn the charges the previous week, saying no material evidence had been placed before him.

A distraught Sithole said: "Standard Bank is a terrible employer, with a lousy industrial relations policy. They are not what they profess to be in newspaper and television advertisements. They are a racist institution, victimising employees on the basis of colour."

He said the slogan "looking ahead..." was a lot of hogwash, repeated merely for marketing purposes.

"The sloganeering is hollow talk ... nothing more than self-aggrandisement by the bank," said the 26-year-old Sithole.

Instead, Sithole has expressed more confidence in the country's courts of law.

"Why, even the court that tried me simply withdrew the charge because the bank had failed to provide evidence to back up their claim.

"Now, in their own tribunal, they have the gall to overrule the court's decision. That is stinking stuff," he said.

Why is Sithole so bitter?

He is walking the streets of Daveyton unemployed, even though the bank could not prove its allegations in court.

After a few appearances, the magistrate withdrew the charges on December 10 because there was no implicating evidence.

The bank, in their letter of dismissal, charged that Sithole had acted dishonestly.

"We advise that you have been dismissed from our service with effect from December 23 for your dishonesty relating to your involvement in the fraudulent call account withdrawal, and the subsequent encashment of the bank cheque."

The bank said this after their internal disciplinary inquiry on December 23.

Asked why the institution went ahead to punish Sithole even though the Magistrate's Court had withdrawn the

■ CHARGES WITHDRAWN

But black employee was still discharged:

case, a spokesman for the bank said he could only speak for the bank and not the magistrate.

"The disciplinary hearing is an internal matter and it has made its ruling.

"If Mr Sithole is unhappy about the judgment, he may appeal. I would urge that he appeals, rather than taking the matter to the media.

"As for the court's decision to withdraw the matter, I cannot speak for the magistrate," he said.

Sithole has denied he had anything to do with the encashment of the R18 000, except having to write out a cheque in the client's favour.

Even then, he had alerted senior officials about the discrepancies in signatures on the actual cheque and the specimen signature kept on the bank's files.

The two officials, a black and white women, overlooked the discrepancy and insisted that Sithole make out a cheque for R18 000, he said.

The bank could not accept that Sithole's responsibility went as far as writing out a cheque, with the rest being processed by "authority above me".

"Despite this knowledge, they went ahead to punish an innocent man.

"I actually find this whole saga laughable. The cheque I had written out had been approved and verified by my seniors, a black and white senior officer of the branch.

"How can I, a junior, take the blame for what had been approved by my seniors. This whole thing is farcical. I am convinced that I have been victimised because I am just a little man within the system," said Sithole.

Sithole said it was interesting that only one of the senior persons who had approved the transaction had been dismissed. The senior white employee has not been dismissed, he said.

"Was it by coincidence that a white woman, party to the same decision to cash the cheque, remained employed, while a black woman was dismissed?" asked Sithole.

"The only conclusion I can come to is that the bank is racist."

59

Racism claim is denied by bank after dismissal

50 vetam 20/11/93
By Joe Mdhlela

Standard Bank's response to ex-employee's allegation:

THE Standard Bank has strongly denied claims by a former employee that it was racist and victimised employees because of their colour.

This is in response to an article published on this page last Wednesday.

Standard Bank Human Resources general manager Dr John Verster was responding to allegations by Mr Jabulani Sithole.

Sithole claimed he and another black employee had been dismissed for dishonesty while no action was taken against a white woman allegedly also involved in the cashing of an R18 000 cheque at the bank's Alrode branch. He was reported as saying the bank was racist.

Verster said the bank had a well established disciplinary procedure which it followed independently of any criminal charges brought by the State. Disciplinary action was taken

irrespective of the race or sex of an employee where circumstances justified it.

In the case in question, the due process in the bank's disciplinary procedure was followed. After a thorough internal investigation and disciplinary hearing, Sithole and another employee were dismissed.

"Our disciplinary procedure acknowledges and provides for the right of an employee to appeal against disciplinary action taken by the bank. An appeal has been submitted by one of the employees and is receiving full and careful consideration. Furthermore, arrangements were made some time ago for Sithole to have access to information to assist him in submitting an appeal should he wish to do so."

Verster said he wished to clarify certain references to criminal charges in connection with the incident which were withdrawn against Sithole in the

Alberton Magistrate's Court.

The bank believed it was inappropriate to draw parallels between a criminal case and a company's internal disciplinary procedures. Sithole had not been tried in court as he was reported as having claimed. The case had been withdrawn but not dismissed and could be re-instituted. There was no question of the bank having overruled the court's decision as reported.

"Where there is evidence of a crime being committed, the Standard Bank has a duty as a responsible corporate citizen to report it to the police. It is then for the authorities to investigate and for the Attorney-General to decide the appropriate course of action," Verster said.

"As an employer, Standard Bank adhered to the principles of non-racism and non-sexism. Any breach of these policies was regarded in a serious light and could result in disciplinary action, said Verster.

Insurance out to improve standards

Star 28/11/93

TRAINING within the business sector varies from industry to industry. For example, educational courses in insurance are either excellent or non-existent.

Most insurance companies are many of the larger brokers provide their staff with in-house training and encourage them to study for international qualifications. But there are other in-

insurance practitioners, who make a living "muddling through".

The Insurance Institute of South Africa (IISA) is an educational body, financially supported by most insurance/assurance companies and brokers to provide training and education for all workers at all levels within the industry.

The ultimate interna-

tional insurance qualification is the Fellowship of the Chartered Insurance Institute (FCII) in this United Kingdom, which has now been replaced by the Fellowship of the Insurance Institute of South Africa (FIISA).

This normally takes about five years of part-time study through the IISA. Study books and notes are provided by the IISA and help is provided by staff at the institute.

The intermediate level is the Associate (ACII), which is no mean achievement. It is interesting to note that although students may pass the exams for the Associateship and the Fellowship, the actual titles are only bestowed after election. This emphasises the professional status of the holders.

Other study courses include a basic introduction to insurance, the Certificate of Proficiency and Life Intermediaries Certificate, specialist courses for actuaries and those involved in pension matters, and many more. A certificate is granted on successful completion of each course.

The College of Insurance, at the Institute, holds practical training courses. The training courses cover diverse but specific subjects such as marine, computers, fire, risk management and numerous others. Classes on a wide range of subjects are scheduled throughout the year.

The new Insurance School of Africa is opening at the beginning of April to promote professionalism in insurance. It provides full-time study facilities to enable a graduate who joins the industry to be productive from the first working day.

This will fill a void, as few short-term insured employers have the financial resources for training and educating new entrants to the insurance market.

The Insurance School has launched an intensive one-year, full-day AIISA diploma course, one of the programmes of the Insurance Institute of South Africa (IISA), with examinations on a par with world standards.

The diploma's first six examinations will be held at the end of September, with a further three examinations at the end of March 1994.

Having passed all nine examinations, students will automatically qualify for as associate membership of the South African Institute. But they will be unable to use the letters AIISA until they have worked for two years in the industry.

The AIISA diploma course costs R9 000 which includes classrooms, workshop and lecture costs. In addition, each student must pay R1 000 to sit the IISA examinations. The Insurance School is at Varsity Place, corner Jan Smuts and Bordeaux avenues, Randburg.

Fired bank executive keeps low profile

STEPHANE BOTHMA
and JOHN DLUDLU

FIRE D Absa executive director Bob Aldworth went to ground yesterday amid speculation about his involvement in irregularities at the banking group.

Absa executives remained reluctant to discuss the matter until it was handed over to the police. Unofficially, however, the bank believed about R500 000 had gone astray. Internal investigations were under way to determine if greater amounts were involved. (S)

Attempts to trace Aldworth, 61, for comment on his dismissal on Monday were unsuccessful. His wife Catherine said from the family home in Craighall that she did

not know his whereabouts. "I do not know whether or not he is in Johannesburg or if he will be returning to the city."

Police said no criminal charges were being investigated by Commercial Branch detectives at this stage.

Absa said on Monday that Aldworth's services had been terminated as a result of investigations into certain irregularities.

The affair is highly embarrassing for Absa CE Piet Badenhorst, who appointed Aldworth to manage Allied when it merged with United to form Absa.

SIAM 10/2/93

Absa hands Aldworth case to police

59

ABSA had handed the Bob Aldworth case to the police yesterday afternoon, a commercial branch spokesman confirmed.

Former Absa executive director Aldworth has admitted to taking about R400 000 of the banking group's money which he had hoped to repay with profits from share options.

The police spokesman said Absa executives had had discussions with the commercial branch and had made statements, but more information was needed before a charge could be formulated. No steps had yet been taken to trace Aldworth nor had police arrived at a total figure for the amount involved in the alleged fraud.

Absa sources indicated that the amount mentioned in Aldworth's affidavit might not be the final figure as their investiga-

GRETA STEYN

tions had not yet been completed.

Since the announcement on Monday that Aldworth was fired, there was speculation that Absa would not press charges if Aldworth found a way to repay the money. Finance Week took up the cudgels for the disgraced bank chief, saying there was "a need to temper justice with mercy". The plea, however, fell on deaf ears. It is understood Absa CE Piet Badenhorst believes the purge in Absa after the Bankorp takeover would lose credibility if the correct procedures were not followed.

Aldworth put his Craighall home on the market for R1,2m shortly before he was fired. He has not found a buyer yet.

● Comment: Page 10

R/DAW 11/2/72

Sanlam names first English speaker as MD

BIDAM 18/2/93 (59)

CAPE TOWN — The principle of unbundling companies within the Sankorp fold was a sound one and was being investigated by these companies, Sanlam's new chairman, Pierre Steyn, said yesterday.

The naming of former MD Steyn as chairman and of former senior GM: individual assurance Desmond Smith, 45, as MD was made at the AGM yesterday. Smith, an actuary and the first English-speaking MD of Sanlam, has been with the organisation for 25 years.

Sankorp CE and deputy chairman Marinus Daling, 47, has been appointed deputy chairman of Sanlam. The appointments follow the decision by former chairman

Steyn said Sankorp, the investment subsidiary arm of Sanlam, would not be unbundled itself as its role was to monitor the performance of its underlying subsidiaries. Gencor and other companies in the group were looking at the pros and cons of unbundling, Steyn added.

LINDA ENSOR

Steyn pointed out that while Sanlam in the past was an exclusively Afrikaans organisation, it now served all South Africans in the middle to upper income groups and would continue along this path. Black policyholders formed a significant proportion of Sanlam's client base and this sector was the fastest growth area.

As the Sanlam board of directors was elected by policyholders, Steyn foresaw that blacks would be elected and that their percentage of managerial staff would increase.

He reiterated Sanlam's policy that investment in housing would be made subject to the guarantee of adequate security and the achievement of an adequate investment return. The assurer would not support subsidising housing, nor would it place money at risk through rental boycotts, he said. □ Van den Berg called for a "clean-up" of business by eradicating the lack of business ethics, and for action to be taken against corruption.

6/10/93 18/2/93
**Ex-MD told
to repay loan**

SUSAN RUSSELL

FORMER African Bank MD and CEO Gaby Magomola has been ordered to repay R102 495 he borrowed from his former employees, in terms of a judgment granted against him in the Rand Supreme Court this week.

Judge H Daniels ordered Magomola to pay African Bank R102 495 plus interest of 22% a year from July 2 1991 to date of payment.

African Bank CE Jacobus Theron said in an affidavit the claim was for outstanding amounts which had been borrowed by Magomola under the bank's staff loan scheme.

Magomola had initially given notice that he intended opposing the application. But when the matter came to court this week the judge was told that Magomola would no longer oppose the application.

News in brief

Sowetan 23/2/93

I was misled, says Aldworth

SACKED Amalgamated Banks of South Africa executive director Bob Aldworth says he was misled into signing an affidavit in which he admitted to misappropriating more than R400 000. (S9) (S4)

In a statement sent to the SABC and passed onto Sapa, Aldworth implied he had been stabbed in the back by his former employers, claiming the affidavit had been dictated by an Absa attorney and given to him to sign "as purely an internal record".

Storm clouds around Absa have not disappeared

STAR 25/2/93

Controversy and infighting have plagued the group since its birth, reports the Finance Staff.

MUCH as the controversial chief executive of the giant Absa group Piet Badenhorst (56) would like to avoid it, South Africa's super banking group with assets exceeding R80 billion, has consistently been in the public spotlight for over three years.

For much of the birth of Absa — the Amalgamated Banks of South Africa, consistin of Volkskas, United, Trust Bank and the Allied — has been accompanied by bitter infighting, litigation, retrenchments and a flight of top bankers from the group.

A number of top bankers have either resigned, taken early retirement or were retrenched in recent months. The latest resignation was that of Piet Liebenberg, previously head of Bankorp, who left the group late last year, a year before his intended retirement date.

At the same time another top executive Hennie Diederichs, who was head of both Volkskas and Trust Bank, resigned to join the Post Office.

Several other senior managers have been retrenched, only to be snapped up by rival banking groups, the latest being Angus Prentice who worked under Aldworth at the Allied.

However, at the weekend it was announced that Absa has employed eight overseas bankers to provide the group with skills in the international banking area.

Badenhorst's bitter dispute with Kevin de Villiers, the previous MD of Allied, was the focus of a bitter ongoing saga; both in the courts and on corporate level.

De Villiers apparently earned Badenhorst's wrath by publicly opposing United's offer for Allied; he sided with First National Bank who was also interested in getting control of Allied. United finally had to increase its offer by nearly R200 million to gain control of the Allied.



Chief executive of Absa . . .
Piet Badenhorst.

In addition Badenhorst has been involved in a number of disputes with various newspapers, magazines and radio stations.

And if allegations made by Aldworth — whom Badenhorst only last year described as "the best banker in South Africa" — are anything to go by, the storm clouds have not disappeared yet. Not for a long while.

A number of senior journalists have been "blacklisted" by Badenhorst for comments they made during the United's fight for control over Allied Bank in 1990/91.

As chief executive of the United, SA's largest building society, Badenhorst embarked on a merger/takeover trail in the mid-'80s which first included Volkskas, then Allied and last year he also managed to take control of the ailing Bankorp group, the parent company of Trust Bank and Senbank.

Persistent rumours allege that this deal was facilitated with a R1 billion "soft loan" from the Reserve Bank. A spokesman for the Reserve Bank declined to comment.

In spite of all the controversy, banking analysts insist that the super-bank has enormous long-term potential and that if anyone can make the mergers and take-overs work, it will be Badenhorst.

In addition, they say, in order to compete on international markets, South Africa needs large banks with adequate capital to take on the banking giants of the world. □



Police move to extradite Aldworth

RAY HARTLEY (59)

POLICE were preparing an application to have dismissed Absa banking executive Bob Aldworth extradited from Britain and brought to trial in SA for the alleged theft of R414 000 from Absa, an Absa spokesman said yesterday. *BIPAM*

The spokesman confirmed that charges of blackmail and defeating the ends of justice were also being prepared against Aldworth. *3/3/93*

Moves were also being made to sequester Aldworth's SA estate in an effort to recover money allegedly stolen from the group by the former banker, the spokesman said.

The sequestration of assets believed to be in Aldworth's wife's name — including his R1,2m house — were being investigated, a banking source said.

Aldworth signed an affidavit admitting to cancelling a personal loan for R414 000 from Absa Bank, but subsequently claimed he had been unaware of the legal consequences of the statement.

Absa lawyers have meanwhile released a transcript of the meeting at which the statement was signed, in which Aldworth said he was aware that he was admitting to theft.

st
sj
A
a
D
u
in
(
te
ta
in
c
c
it
a
a
I
a
M
H
e
H
H
a
c
c
t
t
v
c
s
a
e
e
7
4
s
a
t



5/10/93
13/12
701

Nedcor staff dispute

(59)

THE Nedcor Staff Society has declared a dispute with Nedcor over the bank's apparent unilateral cancellation of a recognition agreement signed in 1986. The dispute is due to be heard in the industrial court tomorrow.

Handwritten text at the bottom of the page, possibly a page number or reference.

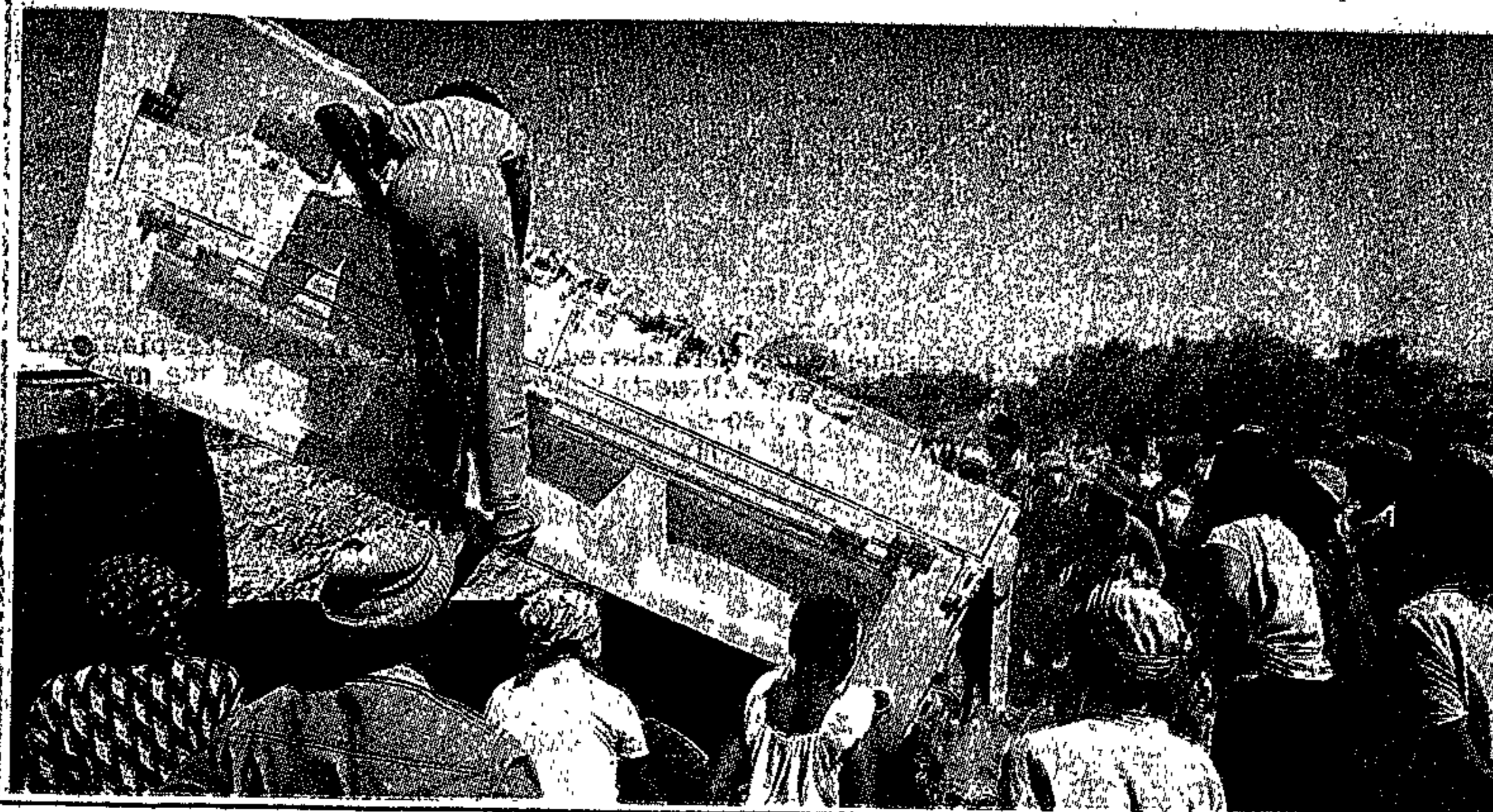

Union wins order against bank group

SHARON SOROUR, Labour Reporter

THE Industrial Court has ordered the Perm to withdraw certain new conditions of service it planned to implement in the Western Cape without the approval of the Financial Institutions Workers' Union.

Union regional organiser Mr Adrian Coetzee said the court case arose after the union urgently applied to the Industrial Court to limit Nedcor Bank from implementing modified conditions of service for their employees regarding disciplinary procedures. The Perm is a division of Nedcor Bank.

In the ground-breaking ruling last week, the court ordered that the union be allowed to repre-

sent the employees of Nedcor Bank during all stages of the disciplinary process.

"Previously, any employee facing a disciplinary inquiry was entitled to union representation irrespective of the offence or the possible consequences.

"The Perm decided to implement a procedure in the Western Cape whereby trade union representation at disciplinary inquiries would be permitted only if dismissal was the possible consequence."

The court's presiding officer said Nedcor Bank had to negotiate with the union before implementing any new changes to the conditions of service for employees.

● A Perm spokesman involved in the case could not be reached for comment.

59-ARCT.15/3/93

Confidence in business ethics is at 'all-time low'

CONFIDENCE in the ethical standards of SA businessmen was at an all-time low, Cape Supreme Court Judge Pat Tebbutt said at the Ilpa annual congress in Somerset West yesterday.

There had been enough defections from the straight and narrow path in recent years to show that there were numbers of individual businessmen who had sought to depart from the ethical standards expected of them by the public. They had also broken the law in doing so.

"Ethical problems arise when government policies give rise to political or economic uncertainty. The tendency un-

der such circumstances for corruption to flourish, not only among those who administer the country but among those who make their living within the politico-economic environment, has manifested itself over the centuries."

Tebbutt said tough economic conditions were also frequently the cause of falling ethical standards. Business often considered it preferable to make a fast buck than no buck at all.

Ethical problems also arose when the law was not as clear as it could be. Where loopholes in the law existed, people and organisations frequently

skipped through.

In SA the imposition of sanctions had also led to a lowering of ethical standards. "For the country to survive, many firms had to engage in sanctions busting. We know that many overseas firms sold us their goods through intermediaries or under the counter. Nobody can possibly contend that that was honest. However, it was necessary. Ethics gave way to expediency.

"The trouble, however, is that such a concession must not be allowed to extend too far. It must never be allowed to undermine the very structure on which business is based."

Tebbutt said that in any trade-off between ethics and profits, ethics was still generally regarded as good business.

Commenting on the recently formulated Ilpa code of conduct for its fellows, Tebbutt said while such codes were important in providing guidelines for behaviour, they usually were unenforceable. It was difficult to draw the line between what was obviously unethical and what was perceived to be ethical but what was in fact not so — or between what one person regarded as unethical and what another did not.

Vaguely

Most codes of conduct defined the concept which they wished to legislate against too vaguely, if it was capable of definition at all.

"Our law reports abound with cases where voluntary associations have been unable to enforce disciplinary procedures because they have not been clearly defined, or where members against whom disciplinary steps have been taken have had them set aside on review because the aspect they are alleged to have breached has been held to be void for vagueness."

Sanlam addressing staff composition imbalances

SANLAM had relatively more English-speaking and black policy owners than was reflected in its staff composition and it was necessary to address this imbalance which could be detrimental to the standard of service offered, Sanlam chairman Pierre Steyn said at the Ilpa conference yesterday.

"More balance is required in our staff composition, but this must not lead to reduced standards of service or quality. The driving force must be to help people to help themselves, and the main areas in which it can take place are in appointments, personnel development and bursary schemes.

"In all Sanlam's sectors and departments, goals have been agreed upon to address each of the imbalances. When we found we had too few black employ-

ees, too few women in management and too few English-speakers, as well as too few males in purely clerical jobs, we formulated goals to be reached in five years and over 10 years.

"The five-year goals were subdivided into departmental goals on a year-by-year basis," Steyn said.

Activation

To supplement this programme called the potential activation programme — Sanlam had also addressed the need for more qualified blacks by providing bursary schemes.

"Sanlam has already allocated more than 100 special bursaries to black scholars and technikon and university students, some of whom have completed their studies and are now employed

by us. This is in addition to our normal scheme which makes bursaries available on merit to students of all races."

Steyn stressed it was imperative for Sanlam to make the appropriate internal changes to keep abreast of the changing environment. These changes related to changes in business strategy and the composition of its staff.

He also pointed out that Sanlam's employment policy was not based on ideological or political considerations which ignored the realities of the labour market and solid business principles.

"Nor is it based on tokenism which destroys an employee's self-respect and credibility and demotivates every one."

It was vital that recruits be placed and developed in real posts and not fictitious or invented ones, Steyn said.

B10197 24/3/93

59



Adhering to code of conduct vital

Blom 24/3/93
THE Institute of Life and Pension Advisers (Ipa) has revised its code of conduct to make the standards governing the industry and their implementation more stringent.

Newly elected Ipa president Gerard Ehmke said yesterday that in recent times the financial services industry had received adverse comment from the public regarding the measure of protection afforded the man in the street.

"Earlier this year Ipa published its code of conduct whereby fellows bind themselves to adhering to the highest degree of professionalism and integrity in their dealings with the public. I would earnestly recommend that each fellow reaffirm his commitment to the ideals of Ipa by practising the code of conduct in all dealings in the business world."

Ehmke said the boundaries between the various financial services

were gradually blurring and increasing demands were being made by the public for expert advice in the areas of protection for dependents and retirement planning. This trend had been recognised by life assurers in SA and their product ranges had been expanded in recent years to meet these demands.

Ipa's code of conduct requires members to maintain a high level of professional knowledge and skill in order to advise clients in accordance with all the relevant laws, as well as appropriate technical and professional practice and standards.

The code stipulates that in order for an Ipa fellow to maintain his integrity, his client should be made aware of his financial interest in what he is advising him to do. Any fees charged in excess of commission scales had to be fully disclosed.

LPA CONFERENCE-



PIERRE STEYN

New president is Fedlife's Gerard Ehmke

FEDLIFE employee benefits deputy GM Gerard Ehmke has been elected president of the Institute of Life and Pension Advisers (Ilpa).

His election was announced at a banquet last night after the institute's annual congress. *BIDAM 24/3/93*

Ehmke is an associate of the Chartered Insurance Institute and an Ilpa fellow who has spent about 37 years working in the life assurance industry, first with Southern Life and then with Fedlife, where he is in charge of the sale, administration and marketing of employee benefits.

He replaces AA Life MD Joe Gates, who said in his address that fellows of the institute were important participants in the financial service industry.

Promote

"Our challenge remains to promote a peaceful and certain environment in which we are able to secure consumer expectations in the planning of their personal financial affairs, with certainty and integrity," Gates said.

Ilpa inducted 174 new members, one of the highest numbers recorded in its 11-year existence and a 127% increase in the average pass rate of recent years. It now has over 1 400 fellows.

Seven prize winners received a total of 10 awards for outstanding performance in the examinations, including Old Mutual's Hendrik Franzsen, who was overall winner in the life category and also won prizes for business assurance and estate planning.

Old Mutual to lay off 80 ^(S)

INSURANCE giant Old Mutual is to retrench 80 employees in its investments department after developing a new investments management system. *Sowetan 29/3/93*

However, Old Mutual spokesman Mr Theo Hartwig says the company is not "in retrenchment mode" and will in fact try to move some of the retrenched staff into other positions.

"Our previous investments management system was not very successful and as a result our administrative staff in that section substantially increased. With our new system about 80 less positions are available."

Hartwig said. -- *Sapa and Sowetan Correspondent*

Education plan about to usher in 'a new era'

THE SA Institute of Valuers is entering a new era of service to its 1 500 members with the implementation of a compulsory programme of continuing professional education.

The programme, which took almost four years to be passed, will operate over a four-year period and members will have to prove that they have undergone a minimum of 24 hours training over that period.

This forms part of the institute's drive to improve professional standards and to become more acceptable internationally, says chairman Tom Wybenga.

The institute has embarked on a campaign to make the public more aware of the profession and what it has to offer. Greater private participation is needed as most work currently comes from the public sector.

An issue that is also being addressed by the institute is the fact that the valuation of fixed property on many company books is often not undertaken by professional valuers.

Representations are to be made to the Accountants' Board, as it is felt this issue needs to be clarified.

The position at present is that directors are legally allowed to value their own fixed properties without calling in a professional valuer.

The institute is to call for a directive in the standard audit procedures to auditors that if the valuation is done by the directors, this must be clearly pointed out to shareholders/policyholders, says Transvaal executive member Rodney Timm.

Assets

In addition, pension fund and life assurance houses are only required to value their assets every three years and do not need to employ a professional valuer, he adds.

Rode Report editor Erwin Rode says the Insurance Act of 1943, which is supposed to police the property valuations of long-term insurers, is "nothing but a dead letter".

The Registrar of Insurance needs simple rules of thumb to judge these property valuations and the Act should be amended to facilitate this and prevent the

fudging of property values.

Both a capital gains and land tax are also likely to be introduced in the near future — a move that could boost sagging activity levels in the local valuation industry.

However, the basis for valuing the properties could be problematic, as a number of different systems have been introduced worldwide.

Transvaal executive member Delene Burman says as property is fundamental to economic activity, everyone needs the services of a valuer at some time for buying, renting, letting, selling or investing in property.

Any individual or company that needs an independent opinion of the value of their property should appoint a valuer to provide an objective, well-researched opinion.

"The institute has been in existence for more than 80 years and while we are proud of what we have achieved in the past, we are continually looking ahead and striving to increase the service we offer to our members, clients and the public," says Wybenga.



Improved training for members

THE SA Institute of Valuers has succeeded in implementing a compulsory programme of continuing professional education for its members, says chairman Tom Wybenga.

"This has been in the pipeline for about four years, but it took time to get this passed as there was some resistance."

The programme will operate in a four-year cycle and, at the end of that period, the members will have to prove that they have undergone a minimum of 24 hours training.

Attendances at the Institute's training sessions have been traditionally low — about 10% of its membership — and the aim of the education programme is to improve the professional standards of members by keeping them informed and updated.

"We offer a number of educational sessions such as a four-day career development programme and seminars and workshops," he says.

In the past two years, the

valuation industry has raised R160 000 for the development of property valuation courses. The latest R25 000 will be used to develop lecture notes for the property valuation component of the new National Diploma in Real Estate offered by Technikon RSA.

National executive member Delene Burman says the institute provides more than 100 hours of education and encourages members to publish articles in professional magazines or present lectures and talks at seminars and workshops.

Represents

Membership stands at about 1500, which represents roughly 78% of the industry.

"The institute will be holding its annual seminar in Cape Town on June 4. The opening address will be given by Cape Town's city planner Neville Riley, while deputy Mayor Clive

Keegan will discuss the future of local housing in SA," he says.

A number of institute members will also deliver papers, which is part of the continuing education offered to members and non-members alike, he says.

The benefit of belonging to the institute is that members' interests are protected, while disciplinary action can also be taken against members not complying with the code of conduct, Wybenga says.

The standards of the profession have been improved over the years and valuers are becoming increasingly professional. "We have been in existence for more than 80 years and are looking at obtaining more international exposure and recognition.

"However, this is problematic as we do not have a specific university degree for the profession, while other countries like the UK offer degrees and therefore do not recognise our qualifications," he says.

DURVAL MARQUES

FM 28/5/93 (79) (88) (59)

Banking on his community

Bank of Lisbon MD Durval Marques's rapid fall from grace has left the banking fraternity and Portuguese community stunned.

Marques (59) resigned this month and was immediately arrested on charges of foreign exchange fraud, theft and corruption (*Economy & Finance* May 21). Particularly intriguing are his alleged dealings with now-deceased millionaire Marino Chiavelli.

"Some R21m could be at stake," says a spokesman for the Attorney-General's office. Marques is free on R150 000 bail but had to surrender his Portuguese passport.

Reputedly earning around R240 000 a year, Marques maintains that his arrest was sparked off by a vendetta against the bank. He refused to talk to the *FM*.

Certainly his public image doesn't fit the profile of a criminal.

Known as a tireless champion of numerous charities — he's a founder member of the Academia de Bacalhau, which supports charities internationally, and the Portuguese Welfare Society of SA, otherwise known as Beneficência. Marques has also been instrumental in building an old-age home for Portuguese in Kensington, Johannesburg. Another home is under construction.

It's not surprising then that the Portuguese community rallied to meet Marques's bail.



Marques ... facing challenging times

Says prominent Portuguese businessman Giorgio Pagan: "I have known him since he first came to SA in 1967 and during that time I don't recall him ever being too busy to

help anyone in need.

"He was particularly involved in helping Portuguese refugees integrate into SA after the (Portuguese) revolution of 1974 and the independence of Mozambique and Angola."

The son of a wealthy family, Marques was born in Pacos de Brandao, in northern Portugal.

After reading economics at the University of Porto, he started his working career as a lecturer at a technical college. But he soon changed direction. In 1961 he joined the Portuguese Ministry of Labour and three years later left Europe for good, heading for Angola. There he joined the Banco de Angola and promptly advanced to a managerial position. In 1967, Marques moved to the Bank of Lisbon in Johannesburg. The bank was established a few years earlier to facilitate trading ties for Portuguese immigrants.

Marques succeeded Charles Marais as MD in the early Seventies. A member of the Institute of Bankers, he is also the chairman of several Lisbon Bank companies.

Described as an energetic and youthful man with many interests, Marques has always been involved in promoting Portuguese culture — first as president of the now defunct Lusitano Football Club from 1973 to 1975; then as director of the Portuguese radio station Radio Paralelo 27 from 1977 to 1983. He is now chairman of M-Net's Portuguese channel.

Pagan says there is a lot of anger at the way in which Marques has been all but found guilty before being tried.

The local Portuguese magazine *O Século* says it has been inundated with calls of support for Marques, particularly from the Portuguese business community.

Marques and his wife, Carol (36), have a seven-year-old daughter, Nicole.

Marina Bidoli

MARIUS VAN BLERCK

Taxing tribute

It can't be often that Anglo American — the epitome of SA's waspish sector — supplies the candidate who walks off with the Afrikaanse Handelsinstituut (AHI) Junior Corporate Businessman of the Year award.

Marius van Blerck (38), Anglo's group tax consultant, received the accolade from the AHI's Junior Sakekamer in recognition of his leading role in the management of a large company. Appropriately, he's quite chipper about it: "The award means a lot to me. It also acknowledges some of the peripheral work I do."

Certainly, his range of interests is wide. He is editor of the *SA Tax Review*, a quar-



Van Blerck ... ahead of the field

terly journal he founded in 1987. He is also chairman of the scientific committee of the SA Fiscal Association, an independent body that co-operates with the Commissioner of Inland Revenue and influences tax policies.

Van Blerck is clearly well liked and respected.

"He's highly competent," says a colleague at the association. "He attracts large audiences to his lectures because he has things to say that demonstrate unusual depths of new thinking and investigation. In particular, Van Blerck understands and studies world trends in taxation. His thinking is usually well ahead of the field."

He is also the SA correspondent for the *Bulletin for International Fiscal Documentation* and a member of the Income Tax Special Court. Van Blerck is a keen squash player and also enjoys painting and wildlife.

He holds a BCom and a masters in tax law from Cape Town University, is a CA and former partner of Arthur Andersen, and serves as an examiner at the University of SA and Stellenbosch University. He is the author of the textbook "Mining Tax in SA."

But the book he really wants to write, and which he says, regretfully, is some years away, is a biography of Deneys Reitz, the legendary Anglo-Boer War soldier who later became a Cabinet Minister and wrote the best-seller "Commando," describing his war experiences.

Reitz, says Van Blerck, was to SA then what Chris Hani has become now. "And if we think we're living through turbulent times, we would do well to draw comparisons from conditions that applied then." ■

Syfrets hit by more resignations

CAPE TOWN — Eight more Syfrets Managed Assets (SMA) staff have resigned to join rival Coronation Asset Management (CAM), bringing the total number of defections over the past week to 16.

The departing group included former SMA MD Leon Campher, leading portfolio managers, researchers and information technology and administrative staff who were approached by Coronation Syndicate to work for its new subsidiary CAM.

Some had already left, while others would leave at the end of June.

The first appointments to fill the gaps left by the eight departed SMA executives were expected to be made next week, Syfrets joint MD Dave Rennie said yesterday.

He said SMA had been approached by many top-level individuals from rival companies and interviews had been held.

All posts would be filled by June 15 but Syfrets would be extremely selective in

LINDA ENSOR (51)

choosing new people. It would employ only high-calibre people able to work as a team within the Syfrets structure.

Rennie described the departure of the group as a "major disappointment" but said Syfrets had the structural depth and strong, committed remaining staff to overcome the problem. *6/09/93 28/5/93*

He said management had started to address the reasons which had prompted the resignations.

"Important as the departing individuals were to Syfrets, the reality is that they were part of a solid organisation comprising researchers, portfolio managers and diverse financial experts — all backed by the most sophisticated computer system operational in any local financial services institution," Rennie said.



DISA DEVELOPMENT CORPORATION LTD

(Incorporated in the Republic of South Africa)
(Reg. No. 87/04269/06)

Interim profit announcement for the period to 28 February 1993

The consolidated, unaudited results for the six months to 28 February 1993 are shown below, together with the unaudited figures for the corresponding period in 1992 and the audited results for the year ended 31 August 1992.

6 months to 28 February (unaudited) 1993	6 months to 29 February (unaudited) 1992	Year ended 31 August (audited) 1992

Absa forks out millions on staff morale

^{Business Day}
9/16/93
ABSAs yesterday told staff members they would each receive R500 in cash to compensate them for the "trauma" of the past year of rationalisation and bad publicity.

Spokesman Jan Snyman confirmed the banking group had decided to pay out a special bonus to all staff members up to senior management level. "We felt it would be a positive gesture after satisfactory results and a period in which many suffered personal trauma because of all the upheavals." The company would shoulder the tax burden, he said.

Analysts said Absa would pay out about R20m to buy staff morale, which was obviously low in a climate of retrenchments.

The announcement of the special bonuses was made on M-Net's business broadcasting station, which Absa has been

GRETA STEYN

using regularly.

CE Piet Badenhorst made the announcement in a live broadcast which could be watched in Absa branches.

(59)
Absa's staff numbered 38 738 at the end of the March financial year, compared with 43 714 at the beginning of the year. The drop of almost 5 000 in staff numbers was split equally between retrenchments and "natural attrition". Absa said 75% of retrenched staff who needed assistance were successfully placed.

Figures provided with Absa's annual results showed its assets per staff member were among the highest in the sector, while its income per staff member was the lowest of the "big four" banks.

B114 10/16/93

MANAGEMENT

Finding a formula to keep key staff

MATTHEW CURTIN

THE INABILITY of management at Syfrets and UAL to hold on to their key asset management teams, successfully wooed by new financial services group Coronation Syndicate, has defocused attention on the prickly issue of staff incentives.

Finding a formula for motivating staff is a problem which confronts every manager. In the financial services sector, the issue is clouded by the fact that by all ordinary measures, the average asset manager, currency dealer or bond trader is handsomely paid in the first place. Yet, financial institutions in SA routinely see some of the best-paid employees jumping ship.

In this year alone, French merchant bank Société Générale pinched Rand Merchant Bank's project finance team, the two main players at Standard Merchant Bank treasury have set off for what they hope will be greener pastures with German-owned West Merchant Bank, while Firstcorp lured two capital market dealers from RMB, and UAL's project team have gone on their own.

The London-based Eurromoney magazine, commenting last month on the departure of 34 members of Credit Suisse First Boston's fixed-income and energy investment banking divisions to rivals in New York this year, says: "The story is a fami-

lar one. The labour market in international banking is one of the most flexible in the world. A large number of institutions performing similar tasks in a geographically concentrated area such as the City of London or Wall Street makes it relatively easy for skilled professionals to change jobs."

At CS First Boston the biggest bone of contention was the compensation package, with the bank understood to be paying its staff at least 10% less than its rivals. The report said personnel departments faced the central problem of providing "the going rate" or risk losing staff.

Merchant bankers and asset management teams in Johannesburg and Cape Town are unwilling to go on record to discuss staff incentives, citing sensitivity of details of their remuneration packages.

What the UAL and Syfrets cases confirm is that "the going rate" is not measured simply in numbers. Syfrets MD Ashton Downy admits some of those who left were being paid more than he was.

There is general acceptance that there must be a premium to be paid for retaining skilled and specialised staff.

Central to the decision by the asset management teams' departure to Coronation was the issue of equity participation. Performance bonuses at Syfrets Asset Man-

agement had a ceiling of 100% of an employee's salary — outwardly generous but tax inefficient — while the company, reflecting the corporate policy at parent Nedcor, does not offer share option schemes.

Coronation chairman Gavan Ryan says one of the attractions in acquiring a listed vehicle for his group's activities is that it can offer share incentives to staff. The old Syfrets team also owns a 35% stake in unlisted Coronation Asset Management.

Downy says Syfrets management has "to address the problem of participation". He says the number of applications — about 30 for half a dozen positions shows how attractive its pay is.

Perhaps the key advantage of equity participation is that it ties performance to some measure of value added to a company. It also sidesteps problems flat salary structures have in motivating staff.

Share incentive schemes can be run in a variety of ways, but they can go only so far in solving the problem of clashing business cultures. It is understood that staff at Investec have done well out of share ownership, but even the solid performance of the bank's stock has not matched the growth in individual parts of the business, spurring a round of negotiations between head office and Investec Asset Management.

There are important differences between a currency dealer and an asset man-

ager, but what they do have in common is youth, their ability to take and manage risk, their desire to be rewarded in line with the risks they take, and the knowledge that they have a good chance of burning out at a young age. This contrasts with the cautious, risk-averse person which provides the backbone of a commercial bank.

Another asset management team head, who declines to be named, says "cultural problems are intensifying as banking becomes more integrated".

His ideal format would be the development of partnerships in the financial services sector, an arrangement pioneered by merchant bank Goldman Sachs. Employees gain a significant minority stake in their business, with options in listed shares — which binds them to the larger group's discipline — and unlisted equity which reflects income from their operations.

But, says management consultancy FSA-Contact MD Olof van Schalkwyk, this does not solve the problem of "sub-cultures" and conflict between entrepreneurs and bureaucrats. The best that can be achieved is a "negotiated comfort-zone".

Firstcorp MD David Lawrence will not comment on his company's approach to the problem, but he hopes Firstcorp's reputation and performance as much as its remuneration packages enables it to attract and keep high-calibre staff.

Industry bodies offer improved education service

B/Dav 14/6/93

EDUCATION is the buzzword in property circles and most of the industry's representative bodies are upgrading and improving this service to members.

The Institute of Estate Agents is committed to offering members and non-members improved education alternatives.

This, in turn, will result in more knowledgeable, efficient and skilled estate agents, which will benefit the public and the broking community.

Munro Donen, chairman of the Commercial and Industrial Brokers Association — a division of the institute's southern Transvaal branch with 300 members — says the association is committed to providing a better service to commercial and industrial brokers.

"This will include providing ongoing education for our members. In the past we have been called elitist for offering our facilities only to members. Non-members will now also be welcome to attend our courses and make use of the services we offer," he says.

The need for continuing education has become more important in light of the recent decision by the Estate Agents Board to do away with the compulsory exam for estate agents.

Course

The institute, in conjunction with the business economics department at Wits University, has introduced a three-day property course covering aspects of the commercial and industrial property market.

The course will also be covered in evening classes over three weeks. Successful candidates will be awarded the Certificate of Commercial and Industrial Specialists.

"Other courses are offered in conjunction with the National Property Academy. The institute is currently considering a system whereby members will have to undergo some

ongoing education before being awarded an approved designation that will separate them from those who have not," Donen says.

Institute members are not only bound by the new stringent Estate Agents Board code of conduct, but also by the institute's own internal code, which goes a step further in trying to protect the public and the industry.

"We are also attempting to create a better relationship with the board and are already working together on some projects. The board is there to protect the consumer and the institute to assist the broker so there is no reason why we should not work together.

Effect

"Deregulation will also have an effect on our industry and the time may come when the two bodies are merged," he says.

While the board recently decided to scrap the compulsory exam, it says it cannot overemphasise the value of undergoing a formal education course.

Chairman Eskel Jawitz says the board will con-

tinue to urge all candidate estate agents with the "necessary degree of aptitude and background" to undertake a board exam course and write the exam.

"As an added incentive, the board is to introduce an approved designation for those who have already passed a board exam, as well as those who intend doing so in the future," says Jawitz.

Extended

The SA Property Owners Association (Sapoa) has also extended its education programme for members by introducing a proactive education programme to encourage underprivileged communities to participate in the industry.

"The intention is to allow those students who excel to be introduced to our members to enable them to gain practical experience and become actively involved in the industry," says executive director Brian Kirchmann.

Sapoa has been a major supporter and funder of the three-year National Diploma in Real Estate course run by Technikon RSA.

COMPANIES

NBS expects 'meaningful growth'

NBS Holdings retrenched 400 staff members during its 1993 financial year in a restructuring process which cost the group R18m in retrenchment costs and fees paid to the external consultants that engineered the process. *B/Nay 22/6/93*

In the group's annual report, CE John Gafney said a large number of staff took up the voluntary retrenchment package and the number of forced retrenchments was kept to an absolute minimum.

The cost of the restructuring process had been written off in full in the 1993 financial year.

Chairman Brian McCarthy expected the restructuring undertaken during the financial year, as well as the new investments, to result in "meaningful real growth" in earnings this financial year.

The group restructured and streamlined its largest division, the Bank Division, and McCarthy said this had had a major impact on its cost base, the benefits of which would be felt for some time to come.

Gafney said for the first time NBS had to undergo a major retrenchment exercise following an in-depth study of the group's business processes and a refocus on the most profitable areas of business.

SHARON WOOD

During the year under review, the group continued to increase its unfunded income to counter cost inflation and its dependence on the interest margin. Unfunded income now contributed about 21% to NBS Bank's total income, McCarthy said.

The proportion of insurance business in the group's activity grew further with the recent acquisition of a 50% holding in Aegis Insurance Company. McCarthy anticipated that direct and indirect insurance activities would contribute a "highly satisfactory" 35% of the group's income during the current financial year.

Insurance comprised of 19.2% of the group's earnings during 1993, compared with 18.8% the previous year. Banking's contribution increased to 59.9% from 53%.

NBS Bank's capital adequacy ratio remained below the required 8% level effective from March 31 1995.

But Gafney stressed that the group had sufficient capital to inject into the bank to meet the requirement. He said: "It has proved more beneficial to hold excess capital in other companies and the bank will only be recapitalised when necessary."

Two sectors employ more

By Day 24/6/93
GERALD REILLY

PRETORIA — The insurance and manufacturing industries are the only significant sectors showing employment growth, Central Statistical Service (CSS) figures released yesterday show.

At the end of the first quarter of this year, 70 684 workers were employed by insurance companies from 68 468 the same time last year.

Between September and December last year, employment in manufacturing increased by 7 300 to 1,39-million from the same four months the year before.

Banks and building societies employed 121 000 at the end of March compared with 124 644 a year before.

The total number of people employed by banks, building societies and insurance companies rose to 191 764 in the first quarter against 193 112 at end-March last year.

The figures also showed mining and quarrying shed nearly 20 000 workers to 576 236 in the four months to end-December last year. The construction sector lost 9 000 workers, bringing the force down to 337 000.

Economists said the marginal increase in insurance and manufacturing employment did not indicate a trend. Employment was likely to shrink over the rest of this year.

Other CSS figures released yesterday showed a marginal increase in expected wholesale trade sales in the three months to end-May.

In the three months, at constant 1990 prices, sales rose 0,7% to R26,91bn. At current prices, sales increased 8,9% to R35,748bn.

Star 29/6/93
Pay rise for clothing workers could hit jobs

By Tom Hood

CAPE TOWN — The 9,25 percent pay rise won by the country's 100 000 clothing workers from July 1 will fatten their wage packets by more than R15 million a year.

But, unless the industry can pass its higher labour costs along the line — boosting shop prices — still more manufacturers will be forced to close their factories, warn industry leaders.

Chances are slim, however, of major retailers accepting price increases. Pep Stores chairman Christo Wiese said last week that this year had been the toughest yet for the clothing retailer but business could turn for the better in the third and fourth quarter.

The pay agreement was reached in negotiations conducted nationally for the first time between employers from the four provinces and the SA Clothing and Textile Workers' Union (Sactu) in Johannesburg.

National Clothing Federation president Aaron Searll said that, while the industry was still operating under difficult trading conditions, the settlement was considered fair and reasonable to both sides.

"But, there is no way the industry will be able to absorb this increase and, unfortunately, it will have to be passed on to our customers," he said.

Vendome offers a place for luxury

LONDON — The rarefied world of European luxury goods has caught the scent of a new name with the christening of Vendome, the planned holding company for the portfolio of luxury brands owned by Richemont of Switzerland.

Cartier, Piaget, Mont Blanc, Dunhill and Karl Lagerfeld will be injected into Vendome, which is to be listed in London and Luxembourg if a restructuring of Richemont's subsidiaries is approved by shareholders.

Analysts estimate the new company could be valued at up to £3 billion, making it a member of the FTSE-100 index in London, even though luxury brands are out of favour because of recession.

Richemont, controlled

by the Rupert family of South Africa, has spelt out its plan to simplify its complex group structure by splitting off the tobacco arm, Rothmans International, and combining the two luxury goods businesses, Luxco and Dunhill Holdings, into Vendome.

Dunhill is at present a 57 percent owned subsidiary of Rothmans.

Shareholders

Shareholders in Rothmans and Dunhill Holdings are being offered cash and shares in the new tobacco and luxury goods companies.

Richemont said the new structure would lead to savings and improved marketing. "We are trying to get the operational structure to re-

flect operational necessities," said Johann Rupert, managing director.

The restructuring will also bring to an end Dunhill Holdings' life as a publicly listed company. The company, which was set up by Alfred Dunhill exactly 100 years ago, was listed on the London Stock Exchange in 1923.

Lord Douro, Dunhill's chairman, said Vendome's individual brands would continue to be managed separately and the disappearance of Dunhill's listing was not significant.

"We believe Vendome is one of the most distinguished group of brand names," he said. "It would be immodest to say more than that."

The new company is named after Paris's up-market Place Vendome.

Piet Liebenberg joins Cosab



Piet Liebenberg.

One of South Africa's best-known bankers, Piet Liebenberg, has been appointed chief executive of the Council of Southern African Bankers (Cosab).

The new appointment is effective from July 1.

Commenting on the appointment of his namesake, the chairman of COSAB, Chris Liebenberg, said that the Council was delighted and

fortunate to obtain his services.

"Piet's exposure to the different fields of banking, and his knowledge of the economy, will stand COSAB in good stead".

Piet Liebenberg succeeds Tony Norton who left COSAB recently. He will retain his non-executive chairmanship of Bibliaton '94, a project of the Bible Society of South Africa.

Property firm clinches first 'unit' deal

Property Editor

Capital Property Fund is the first property unit trust (PUT) to buy property by the direct method of issuing units to the seller.

This follows recent changes to the trust deed provisions for property unit trusts.

The new provisions, recommended to the Financial Services Board

by the unit trust advisory committee last year, allow the PUTs to issue units directly to vendors of property, rather than holding a rights issue to raise cash for the purchase.

Capital, managed by the JH Isaacs group, has already used the new system to buy an industrial property from Anglo-Dutch, and says two more such deals are in the pipeline.

The current deal involves the issue of 5 230 000 new units, worth R13,5 million, and the placement of these with a number of institutions in order to give Anglo-Dutch the cash.

JHI (Transvaal) property management director Markham Becker says the new system will allow PUTs to compete on an equal footing with variable loan stock com-

panies or direct buyers and that other funds are expected to follow Capital's lead.

He says that using scrip for acquisitions will also eliminate the discount to market value in issuing new units which was necessitated by a rights issue, and which worked to the disadvantage of existing unit holders who tended not to follow their rights.

Star 21/9/93

Union seeks to stem job losses

■ BY PAUL BELL
LABOUR CORRESPONDENT

The Banking, Insurance, Finance and Assurance Workers' Union (Bifawu) estimates that up to 1 000 workers have been retrenched from banking and financial institutions in the past three months, and is planning a campaign against these job losses.

(59)
National organiser Stan Sigotyala says the estimate, which includes 250 union members, is based on the union's own research of the period June to August.

(42)
Bifawu, which has about 6 000 members —

most of them clerks, drivers, messengers and cleaners — will meet at the Duncan Hall in central Johannesburg at 1 pm today to launch its campaign.

In a statement, Bifawu president Ramontsho Monnakgotla said the most common reasons for retrenchments were mergers, takeovers, rationalisation and restructuring as a result of the acquisition of new technology.

He called for an end to retrenchments and the employment of casual and temporary staff, and for the retraining of workers to equip them for other tasks.

Bank union hits out

INGRID SALGADO

THE 6 000-strong Banking, Insurance, Finance and Assurance Workers' Union yesterday slammed its members' employers and the Black Management Forum (BMF) for using affirmative action to advance their own "parochial" interests. 15112193

"Affirmative action should be reaching the downtrodden. The BMF and our members' management do it the other way around," union general secretary Tom Phalania said after the Nactu-affiliated trade union's weekend national council meeting.

"The union is of the view that affirmative action must be from below. The tendency to recruit black directors whimsically, even those with discredited credentials, must be desisted from. (59)

Urging the forum to consult the union in reviewing its guidelines on affirmative action policies, Phalania said current policies were not reaching the right people.

Improve 'pittance'

Sowetan

By Ike Motsapi 14/12/93

ABOUT 1 000 employees at Mutual and Federal Insurance have petitioned management demanding better salaries and that the company's system of assessing performance be abolished.

The workers, who are members of the Banking, Insurance, Finance and Assurance Workers' Union, maintain that they are being paid a "pittance under the performance appraisal system".

Bifawu official Mr Mfundo Nhlapo said the main grievances concerned:

- The scrapping of the component increase; and
- That the performance appraisal system should not be linked with salary increases.

He said: "We submit that the merit component has always placed our members at a

disadvantage because they are at the mercy of the *verkrampte* line managers of the organisation.

"We find the company's claim that it evaluated the position of each employee to determine whether they should receive increases in pay based on merit to be misleading." (59)

He said the workers were demanding the following:

- A R600 across-the-board salary increase to be effective as from December 1; and
- To train workers in certain areas so that they should improve themselves as far as performance is concerned.

A company spokesman said management had received the petition and that it was studying the union's demands.

Union to fight lay-offs

By Ike Motsapi

THE Banking, Insurance, Finance and Assurance Workers Union is to launch a campaign against retrenchments next month. *Sowetan*

The campaign, starting at the end of January, is aimed at getting employers to halt retrenchments. 17/12/93

Bifawu general secretary Mr Issy Phalama said: "The national council of Bifawu believes that retrenchments cannot be undertaken unilaterally by employers.

"The council deprecates the racist and

inconsistent manner in which retrenchments have been undertaken in the industry.

"We feel that they are being used by racist and conservative managements in the industry as a weapon to dismiss our members."

Phalama said Bifawu accepted affirmative action in principle but said that the union was perturbed by the way this concept was being used by bosses. (59)

"Bifawu is thus of the view that affirmative action must be from below and take account of deprivation at the shop floor.

"The tendency to recruit black directors, even those with discredited credentials, must be desisted," Phalama said.

FINANCE - LABOUR

1994 - 1995

Wage strike looms after Santam mediation fails

(59) AR 4 8/3/94

SHARON SOROUR
Labour Reporter

A WAGE strike is looming in the short-term insurance industry after mediation failed to secure an agreement between Santam Insurance and Sasbo, the largest independent financial union in South Africa.

Society of Bank Officials assistant general secretary Piet Heymans said employees would be balloted for strike action this week and "limited industrial action" would take place.

"Most of our members at Santam indicated they are prepared to take part in industrial action, including a picket at Santam head office," Mr Heymans said.

Negotiations between the 54 000-strong union and the com-

pany ended in deadlock on Friday after mediation by the Independent Mediation Service of South Africa (Imssa) failed.

Mr Heymans said that although the parties had adjusted their final demands and offers "in an effort to secure an agreement", settlement was not reached.

He said: "We lowered our final demand from 10 percent to 9,5 percent (a month on the salary package), while Santam increased its final offer from 8 percent to 8,5 percent."

Santam also extended group life and disability cover to married women and unmarried employees with dependants, but Mr Heymans said although Sasbo appreciated the move "our members want cash in their pockets".

Now it's bankers in bermudas

Business Staff

(59) ARG 8/3/94
SAAMBOU Bank, which probably more than any other South African financial institution has typified the conservative image of bankers, has made a break with tradition with the introduction of less formal clothing for its male staff.

They are now no longer required to wear either a tie or jacket.

Instead they can wear either a stripped light blue or burgundy shirt, which is available with both long and short sleeves, with charcoal trousers.

It also places the male staff of the Pretoria-based bank on an equal footing with its women staff, who have worn corporate clothing for about the past 30 years.

A new addition to the corporate clothing for women staff

are navy bermuda shorts as an alternative to a skirt or dress in the bank's corporate colours.

The new corporate clothing for male staff was introduced at branches countrywide recently.

Saambou Bank senior manager communication and public relations Johan Geertsema said its introduction was part of Saambou's strategy to be the banker for the salaried worker and individual — and to be the friendship bank.

The idea is to provide less formal banking and to be a low cost provider of financial services.

We are breaking new ground and getting away from the image of a dark suit and white shirt, he said.

Mr Geertsema said the corporate clothing was voluntary and staff could decide for themselves whether to wear a tie.

"The staff love it and most have chosen not to wear a tie. The introduction of the male corporate clothing also coincides and correlates with the interior of our banking halls, which are in the process of being upgraded.

"The upgrading, which is spread over three financial years, started about 18 months ago and will be completed in the next year.

"Sixty of our about 80 branches have already been upgraded.

"This programme is aimed at projecting and enhancing the image of a friendly bank and branches are decorated in light friendly colours.

"The counters are also not in traditional straight lines and this contributes to a convivial and friendly atmosphere for clients," he said.

Insurance strike ballot — by mail

Labour Reporter ^{10/3/94} (59)

FINANCIAL union Sasbo has posted 1 300 ballot papers to its members at short-term insurer Santam Insurance amid threats of a nationwide strike.

SA Society of Bank Officials assistant general secretary Piet Heymans said ballot papers had been sent in bulk mail and the union expected replies in the next 10 days.

"We are conducting the strike via a postal vote and members will return their ballot papers to the union in a pre-paid envelope."

Mr Heymans said if the workers decided to go on strike, they would make history in the short-term insurance industry.

He said it was also the first time in the union's history that it had declared a dispute three weeks after signing a recognition agreement with a company.

Sasbo represented 1 300 of the 2 000 employees in the bargaining unit.

The majority of Sasbo members are in the Western Cape. Santam's head office is in Cape Town.

Strike ballot at Santam

By Ike Motsapi

MEMBERS of the 54 000 strong South African Society of Bank Officials employed by Santam Bank will hold a strike ballot after mediation failed to resolve a wage dispute yesterday.

Sasbo members said they would stage

Sowetan 10/3/94
lunch-hour pickets outside the head office of Santam in Cape Town.

The assistant general secretary of Sasbo, Mr Piet Heymans, said the strike ballot would be held on March 28 if management had not responded favourably to their demands. (59)

"The pickets and demonstrations will spread to other Santam offices through-

out the country as a build-up to the strike ballot on March 28," said Heymans.

Heymans said Sasbo demanded salary adjustments of between 9,5 to 10 percent while management made a final offer of between 8 and 8,5 percent.

Santam's management spokesman would not comment "because talks with the union were still under way."

NEWS Retrenched workers stage sit-in

100 lose jobs at loans firm

■ **R2-m DEBT** Trouble at co-op to
lend money to disadvantaged people:

Sowetan 27/5/94

By Ruth Bhengu

OVER 100 EMPLOYEES of Metropolitan Housing Finance Co-operative have been laid off because the company is in financial difficulties. The workers have been staging a sit-in at the offices of Metco's main creditor, the Independent Development Trust Finance Corporation.

They have accused the IDTFC of "unilateral restructuring" of their company and reducing it to a debt collecting agent.

The IDTFC's spokesman, Mr Frans Pretorius, dismissed the claims as untrue. He said his company which had acted "purely as a financier had become a manager" at the request of Metco's directors after its managing director, Mr Ben Peters, was asked to resign.

He said the IDTFC was called in to "scale down the activities of the company so that it could survive".

"This was decided by Metco's board of directors at a meeting. They gave IDTFC the authority to implement a programme to

restructure the company.

"This included cutting down staff members whose numbers were in excess. The other option was liquidation," he said.

Pretorius said Metco would have to retrench between 100 and 110 employees.

"We have agreed to pay an additional R700 000 in a gratuity settlement," he said.

Pretorius said Metco had used R22 million of the R28 million put up by the IDTFC.

It was in arrears to the tune of R2 million.

"Metco fell into arrears because they were unable to collect their debts," he said.

Spokesman for Metco's board of directors Junius Lekgetho confirmed that the IDTFC was acting on Metco's instructions.

Metco was established in 1992 to lend money to disadvantaged people who could not raise loans from banks.

It was financed by the Independent Development Trust Finance Co-operation to the tune of R28 million.

Metco's annual general meeting will be held at its Vereeniging offices on Saturday.

Banks

Biday

From Page 1

tion was used negatively to exclude certain groups from banking loans and mortgages. However, this information can now be used positively to ensure that credit is available to all creditworthy individuals." (59)

Morrison said that while it was probably nominally correct that most banks were not discriminatory, in practice it appeared the opposite was true. 11/6/94

He said the proposed legislation, similar to that existing in countries such as Singapore and Malaysia, would be in line with the interim constitution. It would be used to prove whether banks were unbiased in the allocation of credit, and would facilitate the extension of loans key to equitable development.

Morrison said banks in other countries, while at first sceptical about such legisla-

tion, had eventually found it a useful marketing tool to advertise their social responsibility programmes to the community.

Responding to the banks' argument that the proposed Act would cause operational difficulties, Morrison said this would obviously be investigated. "We will open the discussion to the banking community and other interested parties to find ways of promoting creditworthy candidates at the least possible cost. At the appropriate moment, we will invite input from the banks but in the meantime, positive suggestions and contributions are welcome." LAC

He said the system would not necessarily require additional bureaucrats to implement and manage it. The relevant state agency could assume responsibility.

'Administrative nightmare' danger

Banks oppose bid to outlaw racial bias

Biday 11/6/94

(59)

MOST of SA's major banking groups have responded sharply to reports that government is preparing legislation which, it says, would outlaw racial discrimination in banking.

Bankers said plans to force banks to disclose details of loans and deposits would be an administrative nightmare, and would be a morally retrogressive step.

ANC banking and finance spokesman Neil Morrison said at the weekend that the ANC had appointed a committee to begin drafting appropriate legislation.

It would require banks to report their loans by race and sex, while assets and liabilities would have to be outlined by sub-region and sector. In addition, the race and sex of staff and the location of branches and defaults would have to be listed by neighbourhood.

Association of Mortgage Lenders executive director Martin Milburn-Pyle said most major banks had "deracialised" their loan books when the Population Registration and Group Areas Acts were abolished several years ago. "This means it would be exceedingly difficult to report what the race of a particular homeowner was. It would require a major data gathering operation which in itself is costly."

First National Bank banking GM Bob Wood said the group had long had a policy whereby it did not view race and sex as criteria for lending.

"All our customers are assessed according to identical lending and risk assessment criteria. For years we have promoted race and gender equality in the SA workplace, and have these records available as they are key to the management of

ROBYN CHALMERS and
AMANDA VERMEULEN

our diversity management programme.

"But it is difficult to make definitive statements about a document we have not yet been able to scrutinise and we look forward to receiving this."

Wood said it was crucial that nothing compromised the confidentiality between banker and customer.

An Absa spokesman said such legislation would cause unnecessary delays in the processing of approvals, resulting in additional costs. There would be a need for greater client detail. Additional bureaucrats would be required to implement and manage such a system.

"As with any change in legislation we would like to be part of the process, but at the outset it does not sound desirable."

Standard Bank chairman Conrad Strauss said in the group's 1993 annual report that government proposals for regulation of the banking sector contained some disturbing features.

"The implicit requirement to classify transactions on a racial basis is, in my view, morally retrogressive and the operational implications of compliance would be formidable indeed," he said.

Morrison yesterday questioned the banks' negative reaction to the proposed legislation. "If the banks have nothing to hide, what would they have to fear from the new Act?"

He rejected the claim that requesting race and sex classification of loans and mortgages was morally retrogressive.

"In the past, race and gender classifica-

To Page 2

Bank union may link with Cosatu

CT 15/6/74

Own Correspondent

(59)

JOHANNESBURG. — Cosatu's attempt to gain a foothold in white-collar unions is expected to be boosted later this year with the SA Society of Bank Officials (Sasbo) expected to leave the Federation of SA Labour Unions (Fedsal) and affiliate to Cosatu.

Sasbo assistant general secretary Mr Donald Graham said the decision had been taken in principle and it was "now a matter of selling it to the membership". He hoped this would occur prior to Cosatu's next congress scheduled for September.

The only obstacle he could foresee was Cosatu's alliance with the ANC, which was viewed with concern by some factions within Sasbo.

Mr Graham said Sasbo would incorporate about 4 000 SA Commercial, Catering and Allied Workers' Union (Saccawu) members in the sector.

Sasbo currently had about 60 000 members and was looking at the possibility of merging with fellow Fedsal affiliate, the Financial Institutions Workers' Union, which has about 20 000 members.

Union analysts said Sasbo was not the only Fedsal affiliate talking to Cosatu, with both the SA Broadcasting Staff Association, which represents the majority of SABC workers, and the Transnet Salaried Staff Union exploring the same option.

Insurance staff in wage dispute

Sowetan 15/7/94

By Russel Molefe

BLACK employees at Aegis insurance company in Johannesburg have been picketing during lunch hours for the past two weeks following a wage dispute with management. The workers — who include supervisors, insurance underwriters and filing clerks — are members of the South African Commercial, Catering and Allied Workers Union. They are demanding a 28 percent wage increase. The company is offering eight percent.

Aegis executive manager for industrial relations, Mr Dave Deabin, said picketing workers represented a small percentage of the 600 workers. (59) ~~(152)~~

ir force flights. — Sapa.

police vehicle when in fact it had not.

R20m on loan for electrification

THE Development Bank of Southern Africa had given a R20m loan to the KaNgwane Electricity Supply Corporation to electrify 13 000 homes in the Eastern Transvaal this year in line with the reconstruction and development programme, the Eastern Transvaal government said yesterday.

Premier Matthew Phosa said studies had shown the 61% of households not electrified were in the former KaNgwane homeland, and this demanded an acceler-

JOHANNES NGCOBO

ated electrification drive.

Areas targeted included about 3 900 households in Nsikazi North, 3 400 in Nsikazi South, 3 300 in Nkomazi and 2 500 households in Mswati/Mlodozi.

Meanwhile the German agency for technical Co-operation had donated R500 000 to the Eastern Transvaal administration for job training.

Phosa said the various

heads of department had been entrusted with the responsibility of nominating potential trainees for secretarial, administrative and book accounting courses.

He said the agency would bring an expert in intergovernmental relationships to visit the province.

Phosa said the agency would finance research into the structure and functions of the premier's office in SA as well as in the international context.

'Posts, not jobs, guaranteed'

PUBLIC Service and Administration Minister Zola Skweyiya said yesterday the jobs of white public servants were guaranteed, but that their posts were not.

Speaking at the launch of the SA Advanced Education Project — Windows on Work — Skweyiya said there were 11 000 vacancies within the public service.

"Through Windows on Work we hope to put blacks and women in these positions," he said, adding that the education project's launch came at an opportune time.

Skweyiya said the task of his ministry was to ensure that competition between white and black applicants thrived.

Windows on Work, initiated by the Southern African Advanced Education

JACQUIE GOLDING

Project in the UK as a partnership between the private and public sectors and non-governmental organisations, has now been officially located in SA. Project manager Thuthu Radebe said it was aimed at local black graduates and those who had opted to use their skills abroad.

"Windows on Work intends to arm black graduates with the necessary skills to fill posts locally," Radebe said.

Companies could pay a R30 000 contribution which allowed them access to Windows on Work's database which listed black graduate job seekers and names of black candidates with specific skills.

Department of Education

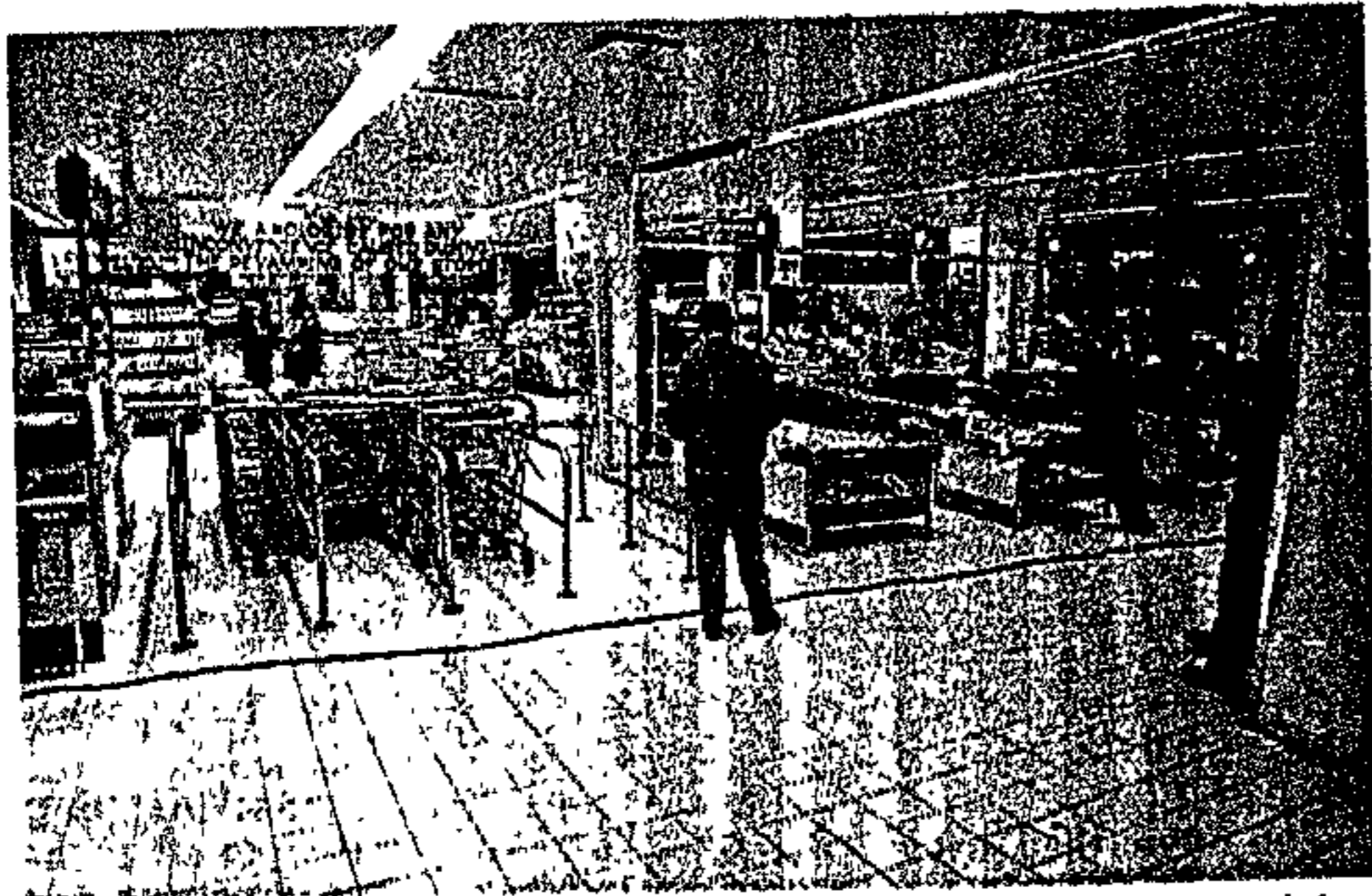

Bank, insurance workers protest

ARG 22/1/84
(69)
JOHANNESBURG. — Banking and insurance workers said today they would start nationwide protests and demonstrations to back demands for higher pay.

Banking, Insurance, Finance and Assurance Workers Union (BIFAWU) general secretary Tom Phalama said the 8 000-member union would take to the streets next week to protest against low salaries and pending retrenchments.

“We are taking to the streets so that the public is aware that all is not well in the banking and insurance industry,” he said. — Reuter.

EMPTY STORE: A few casual workers stand in the closed Pick 'n Pay store in the Gardens Centre, while an ironic banner apologises for “inconvenience caused”.

tryck
1?

world

with the
and



4

BUSINESS DAY, Friday, July 22 1994

Electricity fee hike 'preferred to levy'

MUNGO SOGGOT

INDUSTRY favoured higher electricity tariffs instead of a national electrification levy to fund the reconstruction and development programme's (RDP) electrification programme, National Electrification Forum secretariat member Hendrik Barnard said yesterday.

Barnard said the levy had been rejected as a way of funding the programme but that "big users" of electricity industry accepted that tariffs would have to rise.

Barnard said forum's management committee still had to finalise its proposals on the financing of the electrification scheme, and these would be submitted to government next month.

The RDP target was to make 500 000 new connections a year for the next five years.

Instead of an electrification levy, the targets would have to be subsidised by all the national distributors, he said.

Small local government authorities had access to funding for electrification schemes, much of which would be provided by the Development Bank.

It was also suggested that local authorities scrap subsidies to high domestic users to reduce the tariff hike to industrial and commercial users. (55)

There was general acceptance that "big customers" would have to foot the bill for some of the scheme, but the rejection of the levy meant that the forum would be asking government to help fund the rural electrification scheme.

It was suggested that distributors would finance the electrification schemes for up to about R2 500 a connection. Connections in rural areas sometimes cost at least R3 000 which meant at least an extra R250m was needed.

The establishment of a funding mechanism would reduce the cost of capital for the scheme.

He said there was little point in pursuing foreign loans as these were almost as expensive as borrowing on the local capital market. Foreign grants were scarce and there had not been any of substance.

By **AUDREY D'ANGELO**
Business Editor

THE government will have to ensure that wage rises are not too high and monetary policy remains strict as the upswing continues, Southern Life economist Sandra Gordon says in her quarterly Economic Comment.

If they succeed in doing this an increase in inflation, in line with the cyclical recovery in economic growth, "will probably be more subdued than in previous cycles".

Both Gordon and Board of Examiners economist Rob Lee, in his current Investment Outlook, point out that the international upswing is becoming more generalised. This will benefit SA

Warning on wage rises, monetary policy

through rising commodity prices and better export opportunities.

But Lee points out that the deteriorating balance of payments and foreign reserves position poses a threat to a prolonged economic upswing.

"Another threat now emerges from the recent sharp increase in labour disputes.

"Whatever the politics of this may be, the economic consequences are negative and will be devastating if prolonged.

"Labour disruption directly and immediately harms economic growth and will strongly deter foreign investment.

"If wage increases accelerate without productivity growth this will result in both higher inflation and higher unemployment and further erode international competitiveness.

"Interest rates will have to rise sooner and higher than otherwise and full implementation of the RDP will be gravely threatened."

Lee forecasts an increase in bank rate before year end. Gordon agrees that "there appears to be little scope for a further reduction in short term interest rates. Indeed, an improvement in the capital account is necessary if upward pressure on rates is to be avoided. As a result, the balance of payments remains the critical factor affecting monetary policy."

Forecasting real wage rises of about 2%, allowing for inflation, she says research by the Reserve Bank suggests that labour costs are at the core of inflation.

"Wage settlements are driven largely by expectations of inflation which, in turn, depend both

period has been accompanied by a marked increase in strike action and a sharp rise in wage settlements, reflecting both the political transition and signs of a recovery in economic activity.

"During this time wage settlements have risen to 10.6% while the inflation rate has fallen.

"Average wage settlements of just under 10% are forecast during 1994 as a whole while the inflation rate is expected to marginally exceed 8%."

Another good agricultural season, coupled with a rebound in confidence, "should ensure a strengthening in economic growth in the second half of the year. A growth rate of between 2.5% and 3% is forecast."



ECONOMIST ...
Sandra Gordon

Financial institutions face mass action

Star 30/9/

■ BY JOVIAL RANTAO
LABOUR CORRESPONDENT

A general strike has been threatened at banks, building societies and insurance companies in the PWV by a trade union which has embarked on a campaign for, among other things, recognition, higher wages and an end to retrenchments.

Banks in Johannesburg and

other areas might be forced to close on Saturday when the Banking, Insurance, Finance and Assurance Workers' Union (Bifawu) stages a march as part of its "season for action".

At the march, memoranda are due to be handed to financial institutions. Employers would be given 30 days to respond favourably to the demands, failing which Bifawu would call for a general strike.

"The finance industry must brace itself for a period of unprecedented mass action.

"Given the nature of the industry, this action will result in the complete paralysis of the economy," Bifawu general secretary Tom Phalama said yesterday.

(59)

Demands listed in the memoranda which will be presented on Saturday include:

- An end to retrenchments.
- Establishment of a worker-controlled provident fund.
- Withdrawal of "discriminatory" performance appraisals.
- An accelerated training programme for affirmative action.
- Adjustments for a living wage.
- Job security.
- Recognition of Bifawu.

Finance union plans strike

5.11.1994
ERICA JANKOWITZ

THE Banking, Insurance, Finance and Assurance Workers' Union yesterday informed the finance industry it would call a general strike next month if retrenchments and low wages in the industry did not end.

Bifawu general secretary Tom Phalama said more than 6,000 union members would march in central Johannesburg on Saturday to deliver a list of grievances to First National Bank, Mutual & Federal, Standard Bank and Absa. Employer bodies representing sectoral interests would also be asked to receive the memorandum, which would call for a worker-controlled provident fund, withdrawal of a performance appraisal scheme, affirmative action and union recognition. (59)

If the demands were not accepted within 30 days, the finance industry should brace itself for mass action over the festive season, which would result in complete paralysis of the economy", Phalama said.

Finance union warns of 'season of action'

JOHANNESBURG. — Unionised workers in the financial sector on Saturday gave employers 30 days to respond to demands for improved work conditions and a stop to retrenchments.

The Banking, Insurance, Finance and Assurance Workers' Union (Bifawu) said in a statement coinciding with its "season of action" that it would embark on mass action over the festive season if employers continued to ignore its demands.

Bifawu general secretary Mr Tom

Phalama said that given the nature of the financial sector, "this action will result in complete paralysis of the economy".

(59) CTS/9/94
About 120 Bifawu members — the union had expected about 6 000 — demonstrated in central Johannesburg on Saturday morning to highlight their demands. The operations of banks in the vicinity were unaffected.

Bifawu received a message of support from the ANC's Johannesburg office. — Sapa

3 000 in protest

THE SA Commercial Catering and Allied Workers Union yesterday marched on First National Bank's headquarters in Johannesburg in protest against the bank's refusal to negotiate with the union. *Sowetan*

The march, which attracted 3 000 workers, started at the union's headquarters in Nugget Street and wound its way to the Johannesburg Stock Exchange. Officials of the union said the march on the JSE was meant to show that "financial institutions were not willing to negotiate with unions".

The union claimed that FNB had "blatantly" refused to give them recognition. *23/9/94*

"The march was aimed at forcing the company to recognise the union," said Saccawu publicity officer Mr Sithembele Tshwete. *(59)*

FNB management yesterday said it would respond to a demand for countrywide recognition of the union by 2pm today. A Saccawu official said the union would consider striking if the dispute was not resolved.

Ballots would be held even though the union had been refused access to bank facilities — in spite of a conciliation board recommendation last month.

Negotiations on union recognition deadlocked. Saccawu has claimed that membership of the "sweetheart" union Sasbo was a condition of employment.

Bank will respond to union demand today

JOHANNESBURG. — First National Bank management said yesterday it would respond by 2pm today to a demand for countrywide recognition of the SA Commercial, Catering and Allied Workers' Union.

Saccawu members marched in the city centre yesterday.

The marchers handed a list of demands to managers at the bank's head offices and to Mr Roy Gardner of the stock exchange. ⁽⁵⁹⁾ CT 23/9/94

A Saccawu official said the union would consider striking if the dispute was not resolved. — Sapa

Saccawu accuses Standard

THE SA Commercial, Catering and Allied Workers' Union (Saccawu) yesterday accused the Standard Bank of refusing to recognise the union in the former Bophuthatswana because of its "narrow economic interests".

Saccawu said workers had been on strike for three weeks at the bank's Bophuthatswana operation, Stanbo, mainly over recognition.

Negotiations broke down last week when the bank refused to discuss the issue further until workers returned to their jobs.

However, Saccawu believed an instruction had been issued by Standard Bank SA (SBSA) not to recognise the union as this would have a negative effect on the bank's agreement with Sasbo, the finance union.

ERICA JANKOWITZ

"Saccawu is convinced that the current industrial action is being prolonged unnecessarily by SBSA so as to achieve its narrow economic interest — namely to take over Stanbo at a devaluated share value, which in our view will not be in the interest of our members and the people of the Northwest province."

Saccawu called on customers, shareholders and the provincial government to exert pressure on the bank. It also called on the bank to withdraw ultimatums to members, and threats of dismissal.

Standard Bank said it would only be in a position to respond to these allegations today.

59

Union says Sanlam is 'racist'

59 ARG 14/10/94 (52) 333

□ Ultimatum to insurance giant

INSURANCE giant Sanlam has been given until next week to respond to the South African Commercial and Allied Workers Union's demand for recognition "or face the consequences".

But Sanlam says it is a national company and the union has the support of only 400 workers out of a national bargaining unit of more than 7 000.

The chairman of the Sanlam Sacawu committee, clerk Trevor Christians, said problems for the unions wished to address included low wages, racism and wage disparities along racial lines.

"The workers are loyal to the company — some have up to 40 years' service — but they want Sanlam to reflect the changes in South Africa... to become a non-racial and democratic institution," Mr Christians said.

"We feel we can assist the company to adjust to the new South Africa."

The union had the support of the majority of "disadvantaged", or black, clerks at Sanlam headquarters in Bellville.

Mr Christians rejected Sanlam's argument that they should organise along national lines. He said the Bellville staff could not wait for the rest of the country to catch up.

Union organiser Zuzile Ramcwana said about 300 Sanlam workers complaining of ill-treatment approached the union with the view to affiliating 14 months ago.

"They were complaining about racism, bad working conditions for non-whites and the feeling was the union could help in approaching management and speak on their behalf."

"So we wrote to the company demanding recognition. Their response was that Sanlam was a national company and wanted to deal with issues on a national basis."

"They said to be recognised we had to have the support of 50 percent plus one of company employees nationally."

"We said we could not wait for the rest of the country while we felt the pinch. Any way, we reject their 50 percent plus one because disadvantaged workers are far in the minority at Sanlam."

"We repeated we wanted recognition because we enjoyed the support of more than half the disadvantaged workers at head-office," he said.

Meanwhile, 480 — mostly black — Sanlam staff had joined the union.

Mr Ramcwana accused the company of denying its workers their "constitutional and basic trade union rights".

Union members have been picketing outside headquarters daily since last week.

Sanlam labour relations head Gerrie Botha said the union's lack of national support was "problematic".

Mr Botha said claims of racial wage disparities were "nonsense". The company was very involved in the reconstruction and development programme and in implementing affirmative action.

ROGER FRIEDMAN

Labour Reporter

Work stoppage looms at FNB, says union

Star 15/11/94

■ LABOUR CORRESPONDENT

A national strike looms at First National Bank branches around country, where the South African Commercial, Catering and Allied Workers Union (Saccawu) says it is conducting strike ballots because of the bank's alleged refusal to recognise the union.

The union said it would know the outcome of the ballot by its 12 000 members by the end of the week.

Saccawu media officer Sithembele Tshwete said: "We have substantial membership at the bank's branches and we should enjoy rights accorded to other employee organisations."

He said Saccawu members were experiencing problems taking part in the ballot as

some FNB managers refused to give them time off.

Tshwete said Saccawu members would embark on a strike as soon as results with a majority "yes" for industrial action were received.

However, Louis Moll, head of industrial relations at FNB, said he was unaware of any balloting, except for two branches in the Transkei.

Moll said the bank had held extensive discussions with Saccawu on a number of issues, including recognition.

"FNB accepted Saccawu's offer to validate its right to recognition by supplying us with the details of membership of the union of FNB staff, but to date no such details have been supplied to FNB,"

Moll said, questioning the strength of Saccawu membership at the bank.

59

Based on Section

TOTAL

INTERMEDIATE REMITTANCES

Area: NUMBER No of INTERPROVINCIAL REMITTANCES

PROVINCE

SENDING

Finance workers urged to join union

ARG. 19-20/11/94
JOSEPH ARANES
and MXOLISI MGXASHE
Weekend Argus Reporters (59)

FINANCE industry workers have been told by union bosses that only by joining a union and striking could they get employers to listen to their demands and improve working conditions.

Speaking at a Banking, Insurance, Finance and Assurance Workers' Union (Bifawu) meeting at the City Hall yesterday, union president Lucky Monnakgotla told over 300 workers the industry had been rocked by a recent spate of retrenchments due to companies restructuring and acquiring modern technology.

Bifawu, an affiliate of the National Council of Trade Unions, was formed in the PWV region about 10 years ago, but does not have a branch in Cape Town.

The meeting was the second attempt by the union to launch a branch here.

Mr Monnakgotla said: "Companies' profit margins continue to increase and the shareholders' dividends increase — only the workers suffer."

Management in the finance, banking and insurance industry were not showing any commitment to avoiding retrenchments by training workers to adjust to modern technology.

He said Bifawu was intensifying its September 1993 campaign to highlight these problems among its members and other workers in the industry.

"Use of modern technology was often planned and implemented by management without any input from the workers."

"In deciding to retrench, they do not even think of the implications their actions will have on the lives of the work force."

Mr Monnakgotla said Bifawu concluded that the industry was not committed to sustaining job security and did little, if anything, to avoid job losses. It was more concerned with making profits at the expense of workers' rights.

He said the union, which had catered only for black workers in the industry until last year, was now making serious inroads among white workers who, since the end of apartheid, had realised their fate was inextricably linked to that of black workers.

"Our plan is to continue negotiating with bosses about problems, but if they continue ignoring our reasonable requests we will be left with no option but to go on nationwide strike," said Mr Monnakgotla.

Surge in black workers at banks

(59) BD 22/12/94

SAMANTHA SHARPE

A SURGE in the number of blacks employed in the financial services sector helped lift the sector's employment level to a five-year high of 194 266 in September, compared with 192 672 at the same time last year, Central Statistical Service (CSS) figures released yesterday showed.

Economists said affirmative action policies among banks, building societies and insurance companies were the major factors spurring the 13.3% rise in the number of black workers to 31 149.

The CSS said that while the number of Asian and coloured workers had increased 4.8% and 2.9% respectively, the number of white workers had fallen almost 3% to 129 125.

The statistics were also a sign that the economic recovery was starting to have a positive effect on the job market, economists said. They noted that the financial sector had been remarkably resilient during the recession, creating employment while other sectors were shedding jobs.

The buoyant jobs situation in the financial sector remained in place despite rationalisation among the big banking

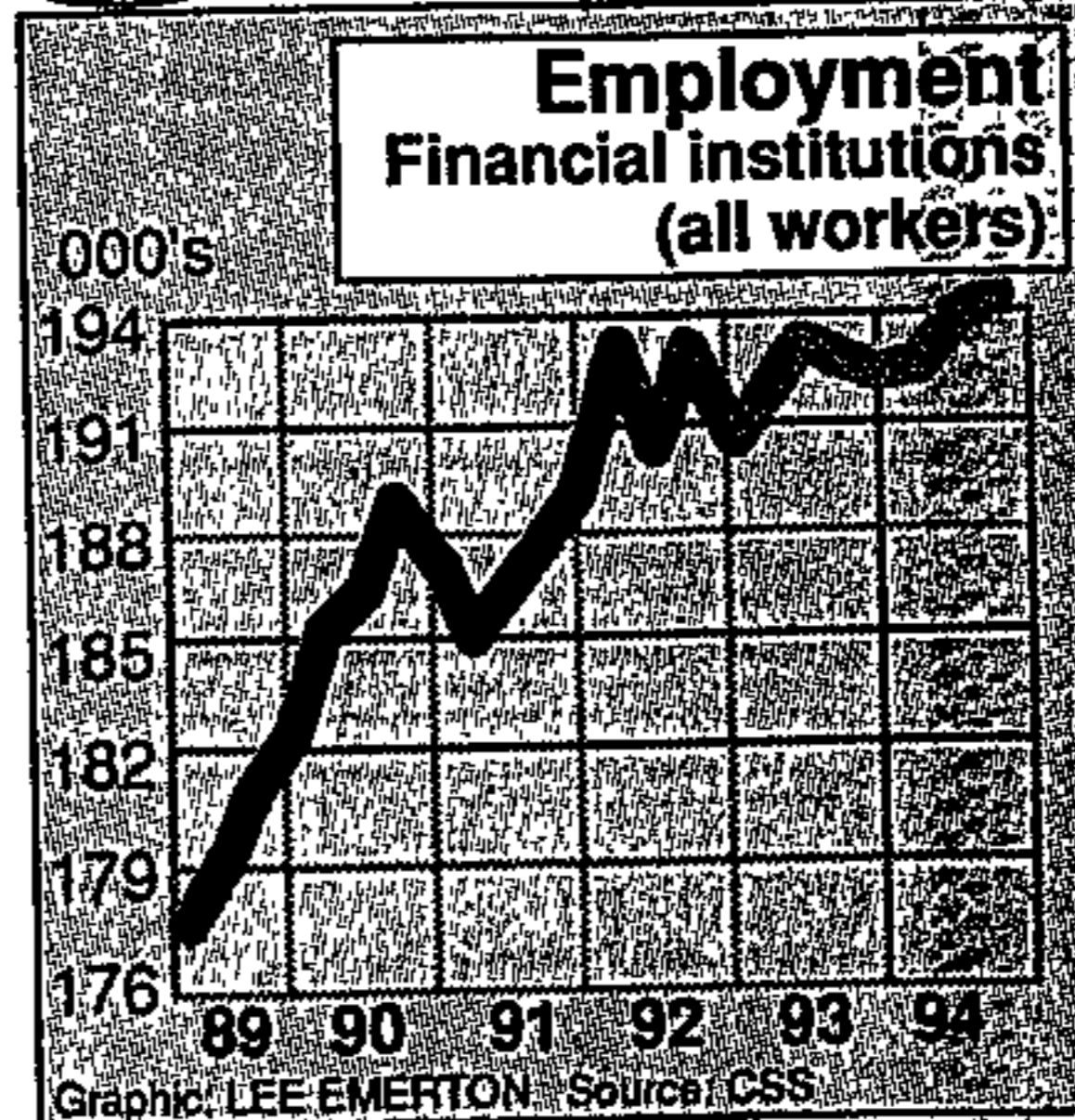

groups. Economists linked the phenomenon to the sector's strength.

Other sectors, too, are showing signs of a tentative recovery in employment.

A Bureau of Economic Research survey released this week showed the first net increase in factory employment in the

□ To Page 2

Banks

(59) BD 22/12/94

□ From Page 1

third quarter since the last upswing. Factory retrenchments had reached their peak at the end of 1992.

The mining sector has reported a levelling out of its employment situation after a downward spiral during the past few years, but a turnaround in the gold mining industry is not yet in sight.

Latest Chamber of Mines figures showed a marginal fall in the number of gold

miners employed in the third quarter compared with the first and second quarters. Chamber members, excluding contractors, employed 356 571 workers in September compared with 357 110 in March.

However, chamber economist Roger Baxter said coal mining members reported a rise to 27 404 workers in the third quarter compared with 26 032 in the first.

Ex-activist heads economic council

(59) CT 29/12/94
FORMER trade unionist and community activist Mr Jayandra Naidoo has been appointed executive director of the National Economic, Development and Labour Council (Nedlac), Labour Minister Mr Tito Mboweni announced yesterday.

Mr Mboweni also announced Ms Debra Marsden, head of the National Economic Forum secretariat, had been appointed programmes director of Nedlac.

Nedlac will be launched in February.

Born in Durban, Mr Naidoo, 34, studied law at the University of Durban Westville and was active in the SA Students Organisation (Saso) before it was banned by the apartheid government.

Between 1987 and 1990 Mr Naidoo was education secretary of the SA Commercial, Catering and Allied Workers' Union, and a central executive committee member of the Congress of SA Trade Unions.

Ms Marsden, who was born in Krugersdorp, studied economics at UCT, from which she holds an honours degree.

She lectured at Khanya College and did research at the Labour Research Service before joining the Consultative Business Movement in 1990. — Sapa

Major coup for Cosatu if bankers' union joins

59 ARG 10/1/95

BACKGROUND TO THE NEWS

ROGER FRIEDMAN, Labour Reporter

COSATU views the application for affiliation from the 75 000-member South African Society of Bank Officials (Sasbo) as "extremely important".

But any affiliation to South Africa's trade union federation giant has to take the Cosatu slogan "One industry, one union" very seriously.

And in Sasbo's case, negotiations with the Cosatu-affiliated South African Commercial Catering and Allied Workers Union (Saccawu) have gone none too smoothly.

While Sasbo is pinning its hopes on Cosatu intervention in its dispute with Saccawu, Cosatu national publicity boss Neil Coleman said the federation intended doing no more than facilitating discussions and ensuring whatever decisions were reached were satisfactory to both parties — and Cosatu.

Sasbo is the largest affiliate by far of the conservative Federation of South African Labour Unions.

But Sasbo general-secretary designate Graeme Rowan said this week he believed Cosatu represented the mainstream of industrial organisation.

"It has worried us for some time that we may have been operating outside the mainstream."

Sasbo applied for full affiliation to Cosatu early in December and were "expecting an answer any day now", Mr Rowan said.

"We would like to affiliate not later than April 1. We still have to give Fed-sal three months notice of our decision to withdraw our affiliation."

Sasbo recognises that their affiliation would represent a major coup for Cosatu and is therefore quite prepared to play hard-ball with Saccawu over the terms for its admission to the federation.

"(Sasbo's joining) will certainly be a major scoop for Cosatu," said Mr Rowan.

He added there was "very little possibility" of Sasbo being interested in "what we regard to be a general work-

The apparently imminent affiliation of the predominantly white financial sector trade union Sasbo to the ANC-aligned union federation Cosatu is indicative of Cosatu's desire to reflect the non-racial democracy South Africa has become.

ers' union" such as Saccawu, a reference to Saccawu's organisation in the catering and general sectors.

"We would represent the interests of workers in the banking and financial sector exclusively. We would consider merging Sasbo with the finance sector of Saccawu under the Sasbo banner," Mr Rowan said.

Saccawu has described this position as "arrogant".

The Cosatu affiliate's organisation in the finance sector has been pinned at around 4 000 members.

Saccawu, meanwhile, has not been impressed by the way Cosatu has handled the issue of Sasbo's decision to affiliate.

General-secretary Herbert Mkhize told the South African Labour Bulletin last month Saccawu delegates had been surprised to see Sasbo observers at the recent Cosatu congress.

"We were not informed that Sasbo would be at congress. Although we would not have said no to their presence, we should at least have been consulted," Mr Mkhize is quoted as saying.

He was adamant that according to Cosatu policy, any union seeking affiliation had to go through an affiliate that was already organised in that sector.

"Unions must not be brought into Cosatu through the back door."

Mr Mkhize argued that Cosatu's principles of worker control and democracy should form the basis of affiliation to Cosatu. He said Cosatu needed to be vigilant when recruiting unions to its fold.

Saccawu's finance sector co-ordinator

Stanley Mngomezulu was more forthright: "Sasbo cannot transform itself into a democratic union, it has to be transformed by Saccawu. This can only be done by the absorption of its members into Saccawu."

Mr Rowan said there had already been a couple of "semi-formal" meetings between Saccawu and Sasbo officials, chaired by senior Cosatu officials.

"They have been trying to get the two disputing parties together. We have been co-operating," he said.

Mr Coleman said Sasbo's application for affiliation, although viewed as "extremely important", should not be seen in isolation.

"Obviously Sasbo's application represents a very significant shift. The profile of Cosatu is shifting from being a largely blue-collar, African-dominated federation to being a much more broadly representative federation including white-collar white, Indian and coloured workers."

He said Cosatu had had a number of approaches and applications over the past year. A number of "loose working relationships" had been established.

"It's a trend that's on the increase," he said, citing the organisation of SABC, airways and public sector workers."

Mr Coleman added: "It is clear that Sasbo is in the majority in the finance industry but it's not just a question of numbers. Equally clear is that Saccawu is a very broad-based service union."

"We are looking at the international experience of how unions are organised in the finance sector."

White-collar Sasbo set on joining Cosatu

FEDERATION of SA Labour Unions finance affiliate Sasbo would pursue its decision to affiliate with Cosatu despite opposition from the SA Commercial, Catering and Allied Workers' Union (Saccawu), Sasbo said.

Sasbo assistant general secretary Donald Graham said the union's executive made the decision late last year and had charged union officials with putting it into action.

However, in the latest SA Labour Bulletin, Cosatu's Zolile Mtshelwane says the federation was placed in an awkward position by Sasbo's request to affiliate. Cosatu wanted to gain the union's 78 500 white-collar workers. But Saccawu's opposition to Cosatu's

ERICA JANKOWITZ

handling of the situation and its insistence that Sasbo merge with Saccawu meant Cosatu's acceptance of Sasbo would be difficult.

"The most probable scenario would be to grant Sasbo observer status in the federation while facilitating a negotiated common ground that will leave both unions satisfied," Mtshelwane concludes.

He says Sasbo approached Cosatu instead of applying to Saccawu as required in union protocol. (59)

Sasbo general secretary Graeme Rowan told Mtshelwane Sasbo was not keen on joining a general union

with retail and catering members. Sasbo preferred to inherit Saccawu's finance sector members and build its own niche within Cosatu.

The unions are, meanwhile, locked in a recruitment war, with Sasbo extending its drive into the insurance sector and Saccawu devising an organising strategy for the finance sector, especially banking. Saccawu was applying pressure on banks to alter their recognition criteria which favoured established unions such as Sasbo, Mtshelwane says.

The unions were still pursuing merger talks under the mediation of former Saccawu general secretary Papi Kganare.

BUSINESS DAY, Friday, January 20 1995

Bank's affirmative action policy slated

59
SAMANTHA SHARPE

THE Reserve Bank's affirmative action policy leaves much to be desired, an article in the latest edition of Tribute magazine says.

While the Bank had approved an affirmative action strategy document in November 1993, its feedback on affirmative action showed that the programme had only taken eight candidates on a two-year cadet programme and created four additional posts, Tribute said in its latest edition.

Of the Bank's national staff complement of 1 930 there were no blacks in general management, 1% in senior management, 5% at professional level, 6% at junior professional level and 33% in "utility" positions.

Put simply there was no black manager, deputy GM or assistant GM, and there was one senior professional manager, the article said.

Tribute said President Nelson Mandela could find himself in a tight spot when he was called to fill two government representative vacancies on the Bank's board of directors — one position has been vacant a year and the other six months.

"While white employees and some directors await his intervention with bated breath, their black counterparts are hopeful Mandela could use this opportunity to announce major corrective measures at the Bank," the article said.

The Bank, which had been criticised by the ANC for clinging to the status quo, recently said it wanted to change but it had found it difficult to find suitable candidates.

Employment rising in financial services sector

(59) BD 14/3/95

EMPLOYMENT in the financial services sector maintained its upward trend, soaring to a new five-year high of 195 784 in December compared with 192 416 in December 1993, Central Statistical Service (CSS) figures released yesterday showed.

Banking sources said the figures were a sign of the robust growth characterising the banking sector and reflected the economy's underlying performance.

While the number of black employees in the financial services sector grew a healthy 16% to 32 345 in the 12 months to December, the number of white employees fell from 131 808 to 128 830, the CSS said.

Council of Southern African Bankers (Cosab) GM Nico van Loggerenberg said the rise in the number of black employees was unlikely to be the result solely of

SAMANTHA SHARPE

affirmative action policies among banks and insurance companies.

He said the trend to increasing black staff, which was welcomed by Cosab, could be attributed to the dwindling resource pool of white employees.

"The financial services sector has realised that it has to look at the broader community to meet the skills base that it requires," he said.

But a Nedcor banking spokesman said affirmative action was the major reason for the growth in black staff. "Most financial institutions will report a swing toward greater recruitment of black staff."

The CSS also said the number of vacancies in the financial services sector had risen sharply in the year to December, with vacancies at banks and institutions up 72,9% to 185 posts.

Standard Bank assistant GM Charles Chemel said the increase in vacancies indicated the upbeat nature of the economy.

He said the rise in vacancies could be attributed to a rise in staff turnover — usually linked to positive economic performance — and to some banks growing their staff.

A Nedcor spokesman said the banking group had seen its vacancy level grow "more or less" in line with the CSS figures. This was primarily attributable to strong business growth, diversification into innovative forms of banking and the opening of new branches.

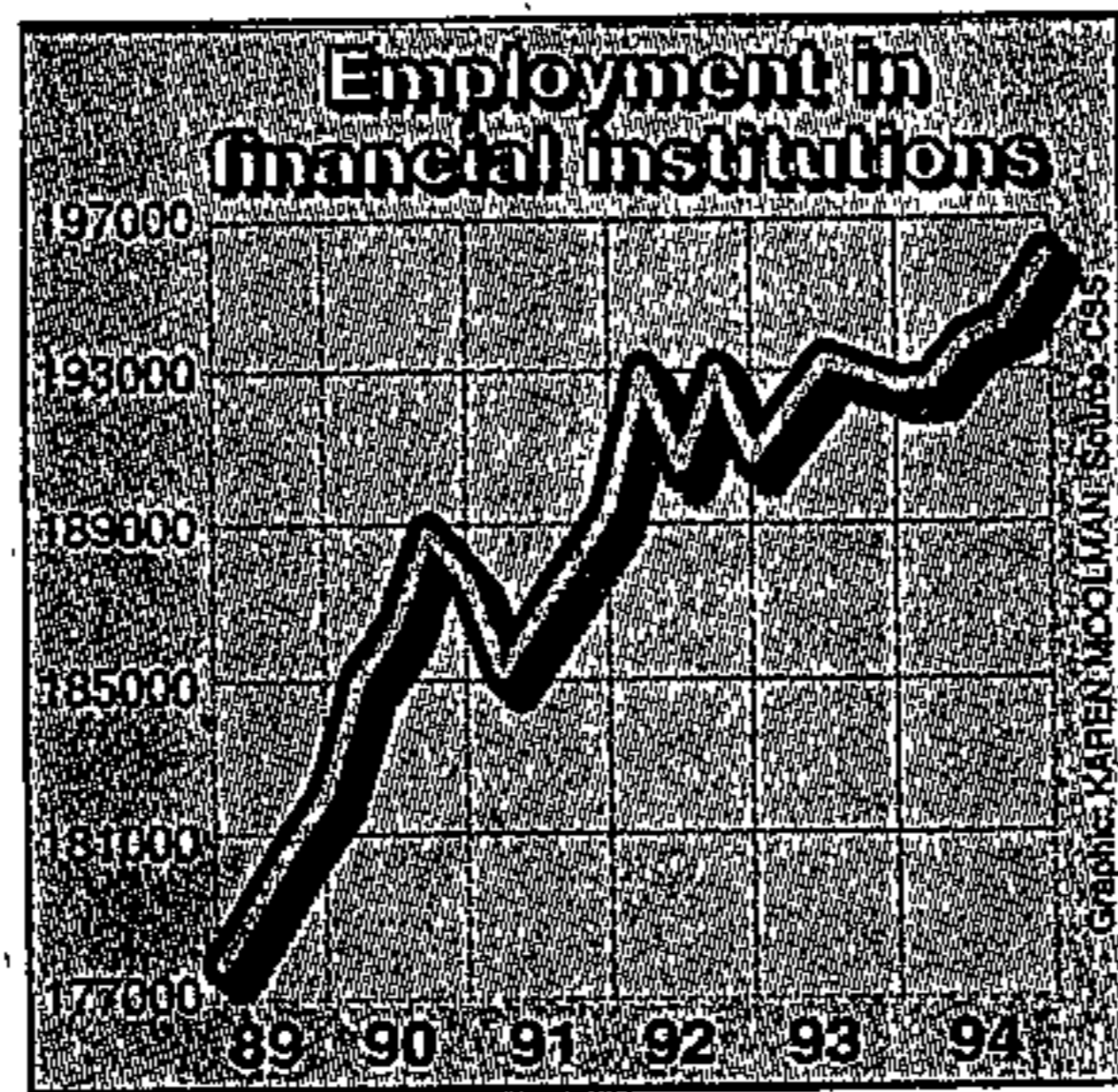

Bank accused of being racist

(59) *South African*
17/3/95

By Mzimasi Ngudle

THE Johannesburg branch of the Banking, Insurance, Finance and Allied Workers Union will convene a meeting tomorrow to discuss its dispute with Standard Bank over racism, wage disparities and conditions of employment.

Bifawu president Mr Siphon Magazi said the meeting would be held at 11am at Ferreira House, Johannesburg.

The meeting follows Wednesday's lunch-hour picket by about 100 bank employees at Standard Bank Centre in Johannesburg in protest against what they called "endemic racism".

The workers, all Bifawu members, waved placards denouncing the South African Society of Bank Officials as a sweetheart union.

Magazi cited an incident of racism early this year when the management refused to provide a pool car for one

black worker who became ill at work while, a month later, a white worker was driven home after learning that a family member had died.

Magazi said this was just one of the widespread racist practices that went unhindered at the centre.

"We continue to receive complaints from our members that, despite the bank's claim to be an equal opportunities employer, shop-floor racism is still rife and moreover countenanced by senior management."

"We demand that the bank agrees to meet our Concerned Workers Committee to seek an amicable solution to the crisis," Magazi said.

Magazi also said white managers are allegedly employing family members.

Mr E Harrington, a senior consultant for industrial relations who received a memorandum of workers' demands on behalf of the Standard Bank chief Dr Conrad Strauss, refused to comment.

Suspension controversy after demos

Abdul Milazi reports on workers suspended for joining mass action

MORE than 30 workers at the Bophuthatswana Building Society were suspended yesterday for taking part in Monday's national day of action organised by the Congress of South African Trade Unions.

South African Commercial Catering and Allied Workers Union shop steward Mr Tshoba Zulu said the workers received notices of their suspension on their desks when they turned up for work yesterday morning.

sawetfan
21/6/95
No work, no pay

"When we told our general manager that we wanted to attend Monday's action, he said it would be treated on a 'no work, no pay' basis, but he never said anything about disciplinary action," said Zulu.

BBS general manager Mr Glen Chadwick, however, rejected this saying he had not suspended anyone

~~142~~ (59) and did not intend to do so.

Meanwhile, Cosatu and the National Council of Trade Unions have threatened to blacklist companies that took disciplinary measures against workers participating in Monday's demonstrations.

Unfair labour practice

Nactu general secretary Mr Cunningham Ngcukana said consumer boycotts, pickets and even legal action would be considered against such employers because the dismissal of workers for staying away from work constituted an unfair labour practice.

The federations will meet today to review the two-week mass action which ended on Monday and to make further decisions. The South African Chamber of Business yesterday estimated 100 000 workers had taken part in Monday's half-day demonstrations, while Cosatu estimated the number at 500 000.

Union in wrangle over numbers

(59) ARG 28/6/95

Staff Reporter

THE Banking Insurance Finance Assurance Workers' Union (Bifawu) and Mutual and Federal Insurance Company have been at loggerheads again.

Usually, a company will sign a recognition agreement with a union if the union can prove it has the support of the majority of the company's workers.

In most industries the majority of workers are black, relatively politically "consentientised", occupy the lowest positions and are relatively easy for the unions to organise.

The financial sector does not fit this mould, however.

Bifawu admits it cannot muster majority support at Mutual and Federal, but argues that unless it is allowed a foot in the door, the industry will remain "a white homeland".

Bifawu says it enjoys the support of more than 400 workers nationally — a "substantive minority". Mutual

and Federal counters that the union's support is insubstantial.

The recognition struggle has gone on for several years now.

The decision of the Labour Appeal Court of June 24 last year should have resolved the impasse.

The court ordered: "The respondent's (Mutual and Federal) conduct in refusing to negotiate wages and terms and conditions of employment in respect of the applicant's (Bifawu) members for the period commencing 1 January 1991 is declared to constitute an unfair labour practice."

But Mutual and Federal is hoping to have the Labour Court's decision overturned by the Appeal Court in Bloemfontein, and the union had its members holding lunch-time pickets throughout the country last week.

Bifawu told Mutual and Federal in a memorandum addressed to chairman Mike Levett yesterday: "We believe

that the union has complied with all minimum legal requirements which might permit it to be recognised as the collective bargaining unit for its members."

The memorandum continued: "Mutual and Federal has consistently resisted and rejected any attempt by the union to negotiate wages and terms and conditions of employment, despite the settlement agreement reached on July 9 1990 between the (union) committee and Mutual and Federal to negotiate in good faith the wage discrimination, and salary increases, which were implemented on January 1, 1989."

The company was "seriously undermining and disregarding" good industrial relations and processes to resolve disputes peacefully.

The union demanded:

- Unconditional recognition.

- That the company stop "selective and discriminatory discipline" of staff.

- A minimum basic salary

of R3 000 a month.

- Equal opportunity housing loans and medical aid schemes.

- Affirmative action and a narrowing of the wage gap between management and labour.

But Mutual and Federal assistant human resources manager Bill Moon said the problem was that the union "does not have the numbers at this stage".

"The numbers" varied from region to region, but were dismissed by Mr Moon as "certainly not significant representation".

Mr Moon said: "We have been engaged in talks for several years ... over the course of time, negotiations will continue."

Bifawu said the company's insistence that it organise the majority of workers was "ridiculous".

The company has been given 30 days to respond to the demands, failing which protest action would be intensified.

Financial service staff ranks swell

Samantha Sharpe

(59) 00 3/7/95

EMPLOYMENT in SA's financial services sector reached its highest level in five years in the year to March, with the number of employees rising 3,2% to 198 846, according to latest Central Statistical Service figures.

The number of black employees rose 18%, reflecting a focus on affirmative action policies.

Economists said the healthy increase in employment was in line with the financial

services sector's underlying growth, which had proved to be one of the more robust sectors of the economy.

Latest Reserve Bank figures showed that GDP in the finance, insurance, real estate and business service sector — of which finance and insurance made up the biggest share — rose at a rate of 4,2% in the first quarter compared with year-earlier figures.

Economists said this showed that the

Continued on Page 2

Employment (59) 00 3/7/95

Continued from Page 1

increase in employment had in no way been at the expense of productivity.

Econometrix economist Azar Jammine said employment growth in the financial services sector had outflanked that in other sectors — including manufacturing.

However, the financial services sector was historically a strong employer and had not suffered a major decline in employment levels in decades.

Old Mutual economist Dave Mohr said the 3,2% increase in employment levels reflected the healthy performance of the banks and life offices, which had shown a steady increase in profits in the past year.

The figures also showed that the number of black employees in the financial sector had grown 18% to 33 497, while the number of whites employed fell to 129 128 compared with a previous 131 236.

Bank spokesmen said these statistics re-

lected the affirmative action policies pursued by most financial institutions.

Absa GM Alec Hogg said his bank, which employed about 38 000 people, had launched an affirmative action campaign. While Absa had not increased the number of people employed; for every nine employees who resigned or retired, at least four were replaced by black staff. Black staffing levels had risen from 15% to about 20%, he said.

First National Bank GM Colin Hunt said higher employment levels in the sector as a whole could be attributed to growth in new business areas and to mergers and acquisitions which had boosted the employment pool. Affirmative action strategies were starting to show in the sector's employment figures, he said.

The fall in the number of white employees could be attributed to natural attrition, not to a deliberate strategy to reduce the number of white employees, he said.

Banks to create more jobs

(59)

Sowetan 11/7/95

Absa planning more branches in townships

By Sibusiso Mabaso

A MALGAMATED BANKS of South Africa's undertaking to reopen all its branches in Soweto and other townships will create a number of new jobs.

Absa executive director Mr Nallie Bosman said more Allied banks had been planned in other developing areas. Speaking at the launch of the newly upgraded Allied Bank in the Dobsonville shopping complex last week, Bosman said the remarkable growth of the then sub-branch to Allied Florida had compelled them to upgrade it to branch status and appoint more staff.

Bosman said during the past few months the staff at Allied Bank had been involved with numerous projects that were aimed at uplifting the commu-



Mrs Elizabeth Ngqumeya (right) of Diepkloof, Soweto, receives a R10 000 prize from Allied Bank development manager Mr David Masekela. She also won kitchen units valued at R40 000.

PIC: PAT SEBOKO

nity. He said Allied Bank has been flagshipped as the Absa brand for affordable housing and praised the Dobsonville staff for the important role they had played with the marketing team in making great headway with the Dream Home Project.

Bosman also announced Absa's plan to open an education centre for Dobsonville Shopping Complex, where people from the community would have access to facilities that provide borrower

education. Branch manager Mr Bernard Montwedi said he would like to reinforce the bank's commitment to building the prosperity of the country through development and community involvement.

"We have embarked on a road that has no formula to success and one that Absa has never travelled. Ours is to reach out and work hard so as to be able to empower our people," Montwedi said.

■ BY PRISCILLA SINGH

Bank staff spurn black colleagues

Star 7/9/95

(59)

Three Volkskas bank employees were turned away from a Spring ball in Bloemhof in the North West province on Saturday because they were black. The women were denied entrance to the Bloemhof town hall "for their own safety" because white guests had objected to their presence and allegedly made threats against them.

It is understood that the ball was organised by Volkskas staff and that the people who were turned away had helped prepare for the event. ANC spokesman Styles Hatfejee said the three were turned away from the hall by other staff members when they arrived with their partners, and were told that the presence of

blacks at the ball would embarrass other patrons. They were also told that their lives would be threatened if they entered, he added. "If at all the personnel believed that the lives of the three ladies were endangered as a result of threats from inside the hall by the whites, then the

staff, including the manager are guilty of tolerating and condoning racism. The ladies' professional integrity as fully employed members of Volkskas/ABSA was undermined and makes a mockery of what the institution stands for in this new dispensation," said Hatfejee.

Bank manager Jorrie Jordaan confirmed that the incident took place, but said that because he was not present it was "none of his concern". Jordaan told The Star that what his staff did after work had nothing to do with him. He also said that the lives of the three staff members would

have been endangered if they were allowed in, but refused to comment further. The women are deeply distressed by the incident and intend taking the matter further with the ANC and North West premier Popo Molefe. Hatfejee also said that some time ago rightwingers left a bleeding pig outside his shop to demonstrate their dislike of blacks. "I don't think they will ever change," he lamented.

Banks employ more blacks, Indians and coloureds

BY RONNY TSHABALALA

A record number of blacks, Indians and coloureds joined the ranks of financial institutions as South Africa moved to the global stage in the field of banking.

Central Statistical Service figures show 8 019 more black, Indian and coloured workers were employed in financial institutions, including building societies and insurance companies, at the end of June this year compared with a year ago.

This increased the number of workers of all racial groups by 3,9 percent from 193 779 to 201 259 workers between June last year and June this year. Of that number, black workers increased by 17,2 percent.

Corporate finance houses have apparently taken this bold step in implementing affirma-

(59) Star 27/9/95
tive action for fear of legislation that would have forced them to employ workers previously discriminated against.

Dumisa Ntsebenza, the publicity secretary of African Law Review and the director of the Bank of Transkei, which was established by the former homeland of Transkei, said such a move should only be welcomed if these were genuine appointments.

"Chances are that foreign corporates stipulated conditions that they would only deal with South African financial institutions whose staff comprises of a certain proportion of blacks, hence the quick clean-up, in order to be seen as making a clean break with the apartheid past.

"Such appointments are doing us a great disservice as they distort the purpose behind affirmative action," he said.

FNB says it is the leader with affirmative action

BD 22/12/95

(59)

Greta Steyn

FIRST National Bank (FNB) was proceeding more rapidly with affirmative action than other banking groups, according to figures provided in the annual report released yesterday.

FNB compared its staffing levels with those of the banking industry as monitored by the University of Cape Town's business school. The figures showed more than 19% of FNB's staff was black compared with an industry average of almost 16%. About 55% of FNB's staff was white — less than the industry average of 65,75%.

The banking group said the number of black officials in management positions had increased by 42,6% during the financial year to end September 1995. It was the group's intention to have 2 000 blacks in its management team and at present growth rates, the target would be achieved by 1998.

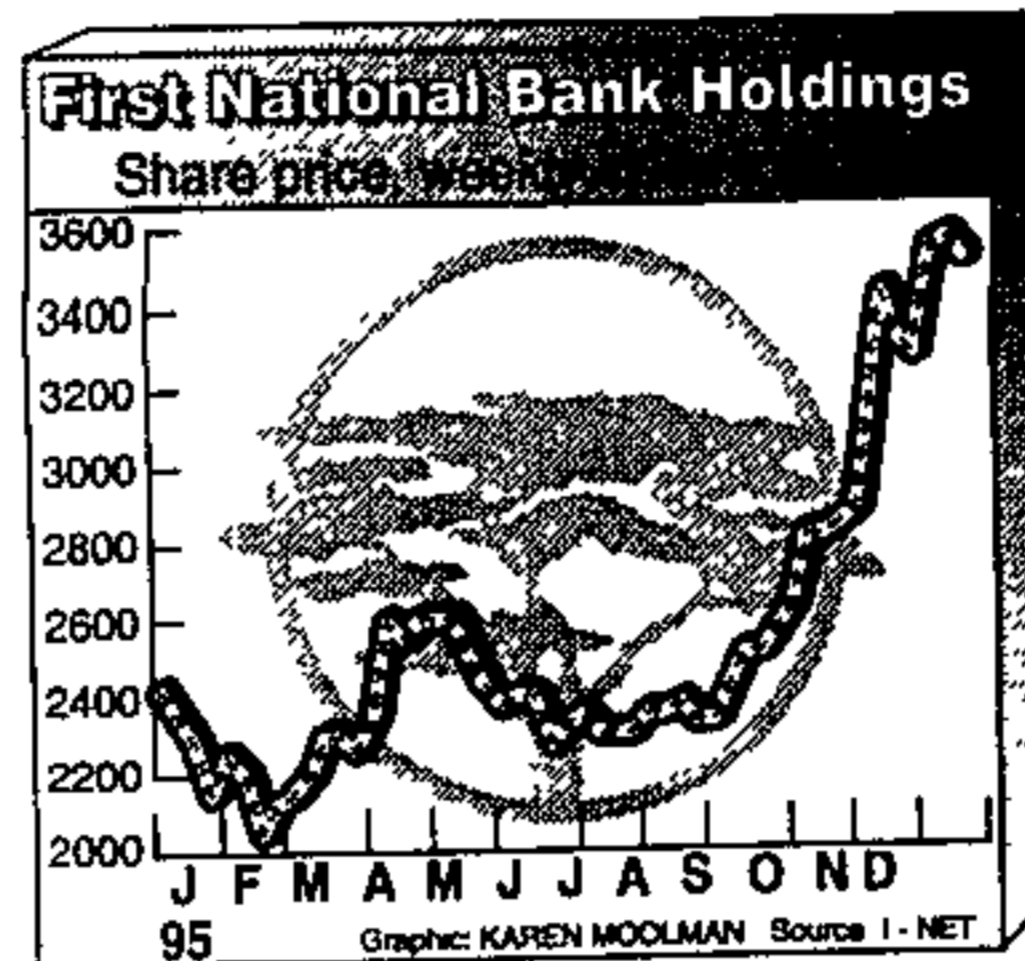

MD Barry Swart said in his review of the year's activities the bank hoped to benefit from business opportunities arising next year when the provincial governments were in a position to borrow. FNB had won more than 70% of all the provincial banking business in SA, trebled its market share of local government business over the past two years and had gained a substantial share of

central government business.

Chairman Basil Hersov said in his review bond and rent boycotts threatened the ability of financial institutions to provide funding for home loans. Hersov said crime and the culture of non-payment stood in the way of economic prosperity and delivery of the reconstruction and development programme. "Unless we can reduce the level of crime, and this includes white-collar crime, all the best efforts of business and government will come to nothing."

He believed the crime problem was huge, but could be overcome, after which sustained economic growth prospects would be good.

FNB reported an increase of almost 23% in earnings per share and almost 21% in dividends for the year to September.

The bank's share closed unchanged at R35 on the JSE yesterday, against a year high of R37 hit earlier this month.

FNB says it is the leader with affirmative action

(59) (57) 30 22/12/95

Greta Steyn

FIRST National Bank (FNB) was proceeding more rapidly with affirmative action than other banking groups, according to figures provided in the annual report released yesterday.

FNB compared its staffing levels with those of the banking industry as monitored by the University of Cape Town's business school. The figures showed more than 19% of FNB's staff was black compared with an industry average of almost 16%. About 55% of FNB's staff was white — less than the industry average of 65,75%.

The banking group said the number of black officials in management positions had increased by 42,6% during the financial year to end September 1995. It was the group's intention to have 2 000 blacks in its management team and at present growth rates, the target would be achieved by 1998.

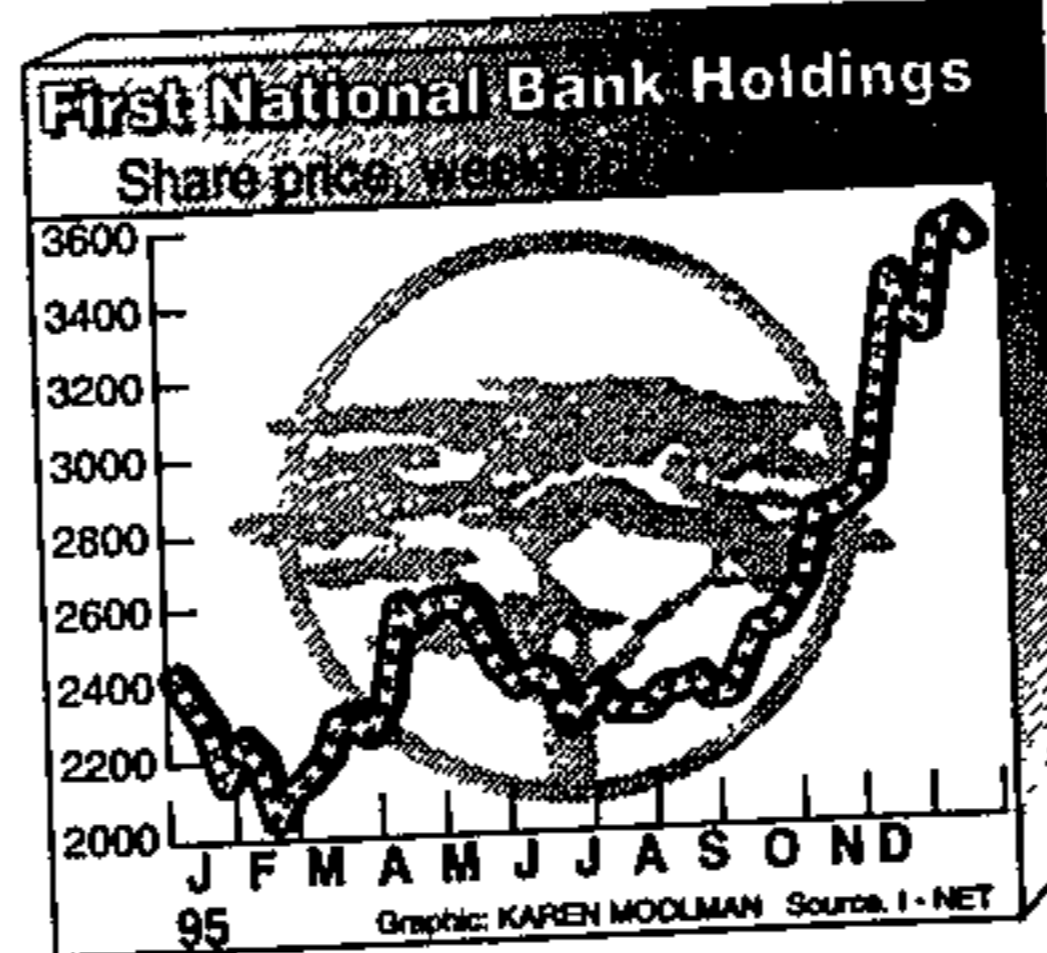

MD Barry Swart said in his review of the year's activities the bank hoped to benefit from business opportunities arising next year when the provincial governments were in a position to borrow. FNB had won more than 70% of all the provincial banking business in SA, trebled its market share of local government business over the past two years and had gained a substantial share of

central government business.

Chairman Basil Hersov said in his review bond and rent boycotts threatened the ability of financial institutions to provide funding for home loans. Hersov said crime and the culture of non-payment stood in the way of economic prosperity and delivery of the reconstruction and development programme. "Unless we can reduce the level of crime, and this includes white-collar crime, all the best efforts of business and government will come to nothing."

He believed the crime problem was huge, but could be overcome, after which sustained economic growth prospects would be good.

FNB reported an increase of almost 23% in earnings per share and almost 21% in dividends for the year to September.

The bank's share closed unchanged at R35 on the JSE yesterday, against a year high of R37 hit earlier this month.

FINANCE - LABOUR

1996 - 98

BUSINESS

Sowetan 18/11/96

Blacks claim raw deal at Metlife

By Isaac Moledi (59) (18)

CERTAIN sections within Metropolitan Life have come out clearly against the insurance company's affirmative action policy, saying the programme is benefiting "male Afrikaners" more than blacks.

A source within the insurance outfit says black middle management is becoming impatient as people who have so far benefited from its affirmative action programme are male Afrikaners, whereas blacks are being "moved from one branch to another in the same positions".

The *Sowetan* source has established that since a black business consortium, led by South Africa's leading black businessman Dr Nthato Motlana, bought a controlling share of the company in 1994, the number of white general managers at the company's head office has increased from two to seven. None of them is black.

The rate of resignation is said to have increased as people who are hired say they are not given decision-making powers.

The source says the provinces mainly affected are Gauteng, Northern Province and Metlife head office in Cape Town.

Metlife, however, denies these allegations, saying its affirmative action programme is still on track.

Metlife public relations manager Mr Nico Oosthuizen says although none of the company's seven general managers at the company's head office are black, his company has made significant progress in relation to promotions.

"We have a clear-cut affirmative action policy that has been implemented over a couple of years and to date we are right on target," says Oosthuizen.

He says the number of white middle management increased from 153 in 1994 to 165 last year. Black increased from 78 to 91 in the same period.

Whereas the number of blacks in senior management position increased from eight to 12 last year, the number of whites remained at 39 during the same period.

Metlife assistant general manager Mr Wallace Albertine says of the 22 members of the top management structure only one is black.

"We have a limited number of positions for general managers but as the company grows, we are confident that new senior positions will be vacant and our objective is to see to it that a significant number of blacks occupy those positions," Albertine says.

More black managers

at Metlife

(59)
BY MAGGIE ROWLEY

Cape town - The affirmative action programme implemented at Metropolitan Life in late 1993 saw the proportion of black employees in indoor middle management and higher positions rise from 12,2 per cent to 19,6 per cent in the 23 months to September 1995.

According to the life office's annual report released this week, if field managers are included, the percentage of black senior and middle managers has grown from 26,2 per cent to 31,6 per cent over the same period.

The percentage of women in indoor middle management and higher positions increased from 9,6 per cent in October 1993 to 15,4 per cent at the end of last September.

Turning to 1996, chairman Nthato Motlana said lower inflation and lower salary and wage increases, as well as an increasing number of life assurance applicants testing positive for Aids, would make strong premium growth difficult to achieve in 1996.

However, he said, being at the forefront of Aids modelling and research had enabled the life office to investigate the possibility of developing a policy which would offer life insurance to people who tested positive for the virus.

Also, Motlana said, while the establishment of the new provincial administrations had meant the relocation of some government employees and hence negative employment growth for some regions, on the whole, the new system gave rise to increased government employment of people in Metlife's target markets, which presented new business opportunities for 1996.

250 staff at Liberty Life to lose jobs

BY LLEWELLYN JONES

Johannesburg — Liberty Life is to rationalise its marketing, sales and administrative staff to reduce unnecessary and duplicated work.

It is believed nearly 250 staff members will lose their jobs.

In a statement released to Business Report late yesterday, the life insurer said it had been re-examining its marketing, sales and administrative procedures over a long period to "retain its pre-eminent position" in the South African financial services industry.

"A lot of unnecessary and duplicated work has been identified,

with the result that the need for a number of functions within the company has fallen away and Liberty Life has unfortunately had to make a number of its staff redundant," the company said.

Sven Forsman, the public affairs manager, said many of the staff were being offered alternative employment elsewhere in the group.

To facilitate this, the life insurer had placed a moratorium on recruitments from outside the company.

An industry analyst said the move seemed to be a general strategy within the life insurance industry as it saw its competitive

advantage eroded by the high costs of maintaining sales and administrative staff.

"The life companies are facing fairly aggressive competition from the smaller asset management companies and from other products like unit trusts, where the upfront entry cost is far lower, at only 5 percent (of investors' money)," the analyst said.

As another example of rationalisation within the industry, the analyst referred to Norwich Life. "Each agent has his own business, thus removing all the expenses related to employing that individual and (thereby) improving margins," said the analyst.

CT (BR) 31/1/96 (59)

Cosatu and deputy finance minister meet

CT(BR) 8/3/96
BY JAMES LAMONT

Johannesburg — Representatives of South Africa's trade unions met again yesterday in Johannesburg with Alec Erwin, the deputy minister of finance, ahead of next week's Budget.

Both Erwin and Sam Shilowa, Cosatu general secretary, declined to comment on the talks, which also involved officials from the National Council of Trade Unions and the Federation of South African Labour Unions.

Shilowa, however, did confirm that the parties had discussed the forthcoming Budget. He said that he believed the unions could still influence the final contents of the Budget.

He said the unions would issue a statement before the Budget announcement.

A union source close to the talks said that the issue of income tax had featured prominently. He said income earners in the R40 000 to R100 000 a year range were taxed too heavily and incomes above R120 000 were proportionately better off. The unions were bargaining for a reduction in middle-income tax.

The source, however, believed the unions demands on the tax issue would be met over the next two to three years, but he said it was unlikely that they would be addressed before next Wednesday's announcement.

Spate of new mines to 'hit copper price'

CT(BR) 8/3/96
BY ROSS HERBERT

Johannesburg — Plunging copper prices were on the cards for the next three years as a result of a spate of recently announced new mines, analysts said yesterday.

The pessimism was led by the London-based Bloomsbury Minerals Economics, which this week predicted a bloodbath in spot copper prices. The predictions cast a shadow on the R1,5 billion Northern Province copper project announced on Wednesday by Palabora Mining, Anglo American and Minorco.

Anglo American and Minorco are studying or developing at least four major copper mines and further investment in troubled Zambian Consolidated Copper Mines (ZCCM).

Copper prices averaged about \$1,33 a pound last year, up 27 percent from 1994 levels. Prices of \$1,01 a pound this year and \$0,82 next year were forecasted by Bloomsbury. Another London forecast put prices of \$0,70 by 1999, with long-term prices settling at \$0,90.

"A price of \$0,82 would be catastrophic for a number of projects. For ZCCM, a price of that level would have a very serious effect if it was sustained for any period," said Jack Holmes, a director at Anglo American, focusing on Zambia, where the company has been evaluating several major copper projects.

"Most of our people in Anglo and Minorco are basing their long-range project judgements on a price

of about \$0,95," Holmes said.

"One of the problems is almost every mine in the world is profitable at \$0,90 a pound. Everyone who can is bringing a copper mine on stream," said Nick Hatch, the head of the mining analysis unit for Ord Minnet in London.

The consensus among six analysts who spoke to Business Report was that supply would grow between 7 percent and 9 percent this year while demand would grow at 2,5 percent to 3,3 percent. Bloomsbury predicted an oversupply of 475 000 tons by August. Last year, world production was about 10,44 million tons. New mines will add 1,1 million to 1,23 million tons of capacity by 1998.

A crucial factor changing the market's dynamics is a processing technology known as solvent extraction electro-winning, which can cut the production cost of copper from about 70c to between 20c and 50c. Not all copper ore is suitable for the process, but it accounts for about 25 percent of world production and is growing.

It is applied to old mine dumps and is planned for many new low-cost mines coming into production in the next three years.

As a result, analysts warned of a possible shakeout in the world market, driven by the new breed of low-cost producers.

"(A shakeout to a much lower price) should happen in theory. But everyone said it would happen in 1993 and it didn't," Hatch said.

Standard Bank 'prejudiced', union says

CT(BR) 8/3/96
BY LLEWELLYN JONES

Johannesburg — Standard Bank would retrench or redeploy hundreds of workers in its latest round of restructuring, said the South African Commercial Catering and Allied Workers Union (Saccawu).

Saccawu said it believed the number of employees targeted because of the continuing activity value analysis was prejudiced against blacks.

The analysis is being conducted in conjunction with McKinsey's corporate consultants.

The bank is evaluating employee functions in relation to

the core nature of the business.

Saccawu members expressed their outrage by picketing the gala opening of the bank's new head office for Standard Corporate and Merchant Bank in Simmonds Street, Johannesburg, on Wednesday.

In a letter of protest handed to Tokyo Sexwale, the premier of Gauteng, Saccawu said the bank was not implementing affirmative action policy to promote blacks to senior management positions.

Saccawu represents about 2 percent of the national bargaining unit and is not officially recognised by the bank.

Graeme Rowan, the general sec-

retary of Sasbo the Finance Union, agreed with a Standard Bank spokesman that the South African banking sector was emerging from years of protection and had to change to meet foreign competition.

"We recognised that change was inevitable and that it has to be properly managed — a lesson which less experienced trade unions have yet to learn."

He said he was unaware of any retrenchments planned at this time, though the union accepted that Standard Bank needed to cut its staff levels by about 20 percent over the next three to five years if it was to remain competitive.

Strikers try to storm Sanlam headquarters

NORMAN JOSEPH, Staff Reporter

ARG 8/3/96 (59)
STRIKING workers tried to storm the entrance of Sanlam's headquarters in Bellville today.

Scuffles broke out outside the building as about 100 workers tried to force their way in.

The workers, all members of the South African Commercial, Catering and Allied Workers' Union (Saccawu) are demanding a 20 percent salary increase and recognition of their union.

After chaos at the entrance and amid loud chanting from the workers, Sanlam's chief executive officer, Desmond Smith, accepted a memorandum, comprising a list of demands, from Bellville Saccawu leader Trevor Christians.

Mr Smith refused to sign the document and returned inside the building.

Several workers scuffled with Sanlam officials but police arrived and restored order.

Sanlam's labour relations consultant Ulrich Stander said the union was in the minority, representing only five percent of the total workforce.

Standard to cut 700 jobs to rein in costs

Adrienne Giliomee

BS 26/3/96

(59)

STANDARD Bank is to shed 700 jobs from its central service division — 10% of the division's workforce — as part of its cost-cutting plans.

The bank, which warned last month that it had to attack costs following an 18% jump in operating expenses to R4,3bn in the year to December, said it would offer incentives for staff to opt for severance and retirement packages. Management accounts for 7% of the cuts, while the remainder span supervisory and operating grades.

Staff could also be redeployed to lower levels or retrenched, depending on whether severance packages were accepted. Similar cuts were possible in other divisions, the bank said.

The job cuts — which Standard said had been run past finance union Sasbo — follow a study on its cost-effectiveness involving US consultant McKinsey & Co which found certain functions were no longer "adding value".

Senior GM (operations) Rod Hyde said the terms of the offers matched or improved on industry norms.

Union members stop work

Bonlie Ngqiyaza

(59)

Liberty Life property, Musi said.

ABOUT 300 SA Commercial and Catering Allied Workers' Union members downed tools for about three hours in Sandton City, Sandton, yesterday in solidarity with four shop stewards who were suspended in early March by Liberty Life Properties.

Saccawu finance sector co-ordinator Joseph Musi said the suspensions had been "unilateral and unprocedural". The four unionists were suspended pending the findings of an investigation into allegations of "dishonesty and failure to comply with standard departmental procedures". The company accused them of "abusing or causing damage to

The union, Musi said, also wanted members' provident funds transferred to Old Mutual, where Saccawu had a trust fund which was under its control. Musi said management had spurned efforts to open negotiations on wage demands, and a letter from the union to management on the issue had elicited no response. Liberty Life Properties declined to comment on the matter. **BD 26/3/96**

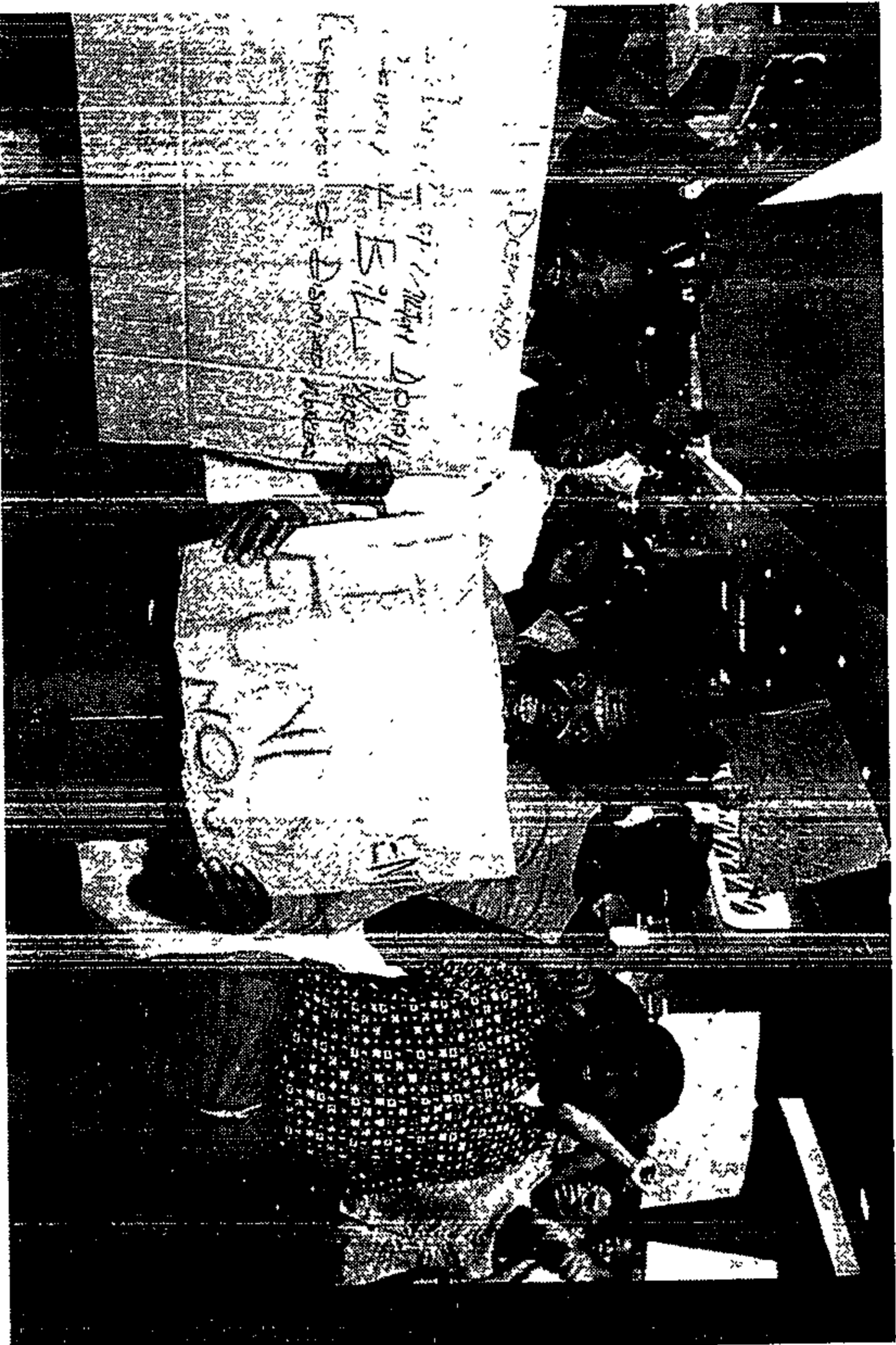

About 300 Saccawu members demonstrated in front of the Sandton City, Johannesburg, offices of Liberty Life Properties yesterday in support of demands for talks on wage increases to begin and for the reinstatement of four shop stewards suspended earlier this month.

Pictures: JOHANNES VOGEL

Bank offers severance schemes

BY NANCY MYBURGH

(59) CT(BR) 26/3/96

Johannesburg—Standard Bank had offered voluntary severance and retirement schemes, which it claimed matched or bettered industry norms, to about 700 of its staff, the bank said yesterday.

This is in line with its stated objective of downsizing. Graeme Rowan, the general secretary of Sasbo, the finance workers' union that claims to have 20 000 Standard Bank members, said the schemes "far exceed customary retrenchment packages".

Rowan said the union was consulted before the packages were offered. The bank had assigned a team of Sasbo members to evaluate the packages, he said.

More such offers would depend

on how many employees took this one, said John Gaunt, the senior consultant for corporate affairs at Standard Bank.

One reason the bank is downsizing is to reduce operating costs, Gaunt said. "Right now about 65 percent of our revenue is getting burned up in operating costs. We'd like to get that down to about 60 percent in the short to medium term, which would put us more in line with world standards."

Those who did not accept the packages could be redeployed to similar areas within the bank if this was possible or face limited retrenchments "as a last resort".

An analysis of the value of various jobs had been "the main vehicle" for improving cost effectiveness, the bank said.

Banking industry braced for job cuts

MD 27/3/96 (59)

Adrienne Gillomee

THE banking industry is bracing itself to shed at least 10% of its 125 000-strong workforce in the next three years, in line with international moves to cut costs.

Banking groups said yesterday that increased international competition, the demise of the retail deposit market and upgrading of technology would pressure them into cutting costs.

Analysts suggested cuts of 10-15% were on the cards, as staff costs were easiest to attack.

The banks declined to be drawn on the figures, but pointed to international trends which supported estimates.

Standard Bank, which unveiled plans this week to cut 700 jobs in its central services division, said it was switching attention to its branches.

Nedcor ruled out a major restruc-

turing but said job cuts were likely.

"In line with international pressures and reducing the cost-to-income ratio there will have to be some rationalisation," assistant GM Ashley Sutton-Pryce said. It hoped to make the cuts through natural attrition.

Absa said it planned to keep staff levels constant, although it would boost income and productivity.

First National Bank said it was not considering new retrenchments.

Analysts said Standard's decision to cut 700 jobs was symptomatic of the problem afflicting the SA industry. Operating cost-to-income ratios were 65%-70%, against the global norm of 55%. Labour-intensive branches had to be reassessed. The banks were investing heavily in advanced technology to lift efficiency. Standard said without the new technology it would have needed an additional 12 000 tellers.

Southern Life strike goes on

BY JEAN FEELY

(59) (42) CT(BR) 28/3/96

Johannesburg — About 100 Southern Life workers said yesterday they would remain on strike until the insurer reinstated a suspended colleague.

"We are prepared to take the strike to the extent where management will try to dismiss us," said a workers' representative, who declined to be named.

The clerks at Southern Life's Johannesburg regional office downed tools on Friday to protest against the suspension of a woman in connection with a fraud investigation they claim was unfair.

Talks between the two parties have failed to resolve the dispute, prompting the workers to ask for an independent mediator to rule on the woman's suspension.

Paul Christie, the general manager of the life customer services unit, said Southern Life was prepared to appoint a mediator, but the clerks would first have to return to work.

BD 29/3/96
**Insurance firm
 wins hearing
 over union row**

(59) **BLOEMFONTEIN** — It could not be said that Mutual & Federal Insurance had acted unfairly when it refused to negotiate wages and employment terms for members of the Banking, Insurance, Finance and Assurance Workers' Union, the Appeal Court decided in Bloemfontein yesterday.

The court found that the Labour Appeal Court (Transvaal) had, on June 24 1994, erred to find that the company's refusal to bargain with the union constituted an unfair labour practice.

About 13% of the company's employees were members of the union — its constitution precludes white employees from membership.

Union members fell into three categories: non-clerical workers (40%), clerical workers (9%) and first-level supervisors (6%). From the racial restriction in the union's constitution, it had the potential to represent all non-clerical employees but did not have the potential to represent the majority in the other two groups.

The company had been prepared to negotiate with the union in respect of one or more categories provided that the union was sufficiently representative of employees in the category.

Appeal Justice Vivier said the union's representativeness in the categories where the company had refused to bargain was minimal, and it could not be said it had acted unfairly. — Sapa.

95

1994

22 310
 9 351

31 661

12 000
 13 042

33 544
 26 925

11 415
 15 510

6 619

31 661

198,3

during the
 garments.

ing existing

ional group
 pleasure in

ries
 ars Limited
 t

00

Ince Cape

RD 3/4/96 (15)
Southern Life strike (59)

ABOUT 150 Southern Life employees have vowed to continue with indefinite strike action and picketing unless management agrees to demands for scrapping the "no work, no pay" condition imposed on strikers.

The strike, which began 10 days ago, was initially linked with the suspension of an employee but the suspension was lifted yesterday. Workers are now also demanding the resignation of two managers.

Returning strikers locked out

(59) (10) CT (BR)
BY NANCY MYBURGH

10/4/96
Johannesburg — Clerical workers at Southern Life's regional office in Johannesburg were denied access to their workstations yesterday, several days after they returned to work following an 11-day illegal strike.

The workers responded by setting off firecrackers, toyi-toying and singing.

The access denial followed the employees' return to work after the strike, precipitated by what workers alleged to be a wrongful suspension of a colleague. She was subsequently reinstated and the striking employees returned to work last Wednesday.

But Stanley Bezuidenhout, a member of the co-ordinating committee for the striking workers, said that on Thursday he and several others found their electronic access cards no longer opened the building's doors.

They were then told that they would not be allowed back to work unless they signed a form stating that they would properly fulfil the terms of their employment contract. Workers were suspicious of the forms, he said, and did not want to sign them.

Paul Christie, Southern Life's general manager of life customer service in Cape Town, said: "Wednesday's return wasn't a proper return to work, but merely a continuation of the strike in a



SOUTHERN SAMBA Workers toyi-toyi yesterday after being denied access to workstations

PHOTO: JOHN WOODROOF

different format."

He said workers had refused to perform backlogged work and did not fulfil the duties specified in their contracts. That was why they were given the form to sign

before being allowed back to work.

Southern Life had instituted legal action against the workers to prevent them from continuing with demonstrations, he said.

Finance union rejects Cosatu call for marches against banking

(59) 20.11.6/96

Renee Grawitzky

THE SA Society of Bank Officials, a Cosatu-aligned finance union, has rejected the federation's call for marches against banks and says that despite speculation on interest rate cuts, the opposite could occur if money-market shortages reach R12bn.

This emerged after a meeting organised by Cosatu to form a coalition with organisations opposed to recent interest rate hikes. The eviction of thousands of home owners was also

discussed, sources said. Organisations which attended the meeting included the ANC, SACP, ANC Youth League, the Consumer Union and non-governmental organisations.

Cosatu assistant general secretary Zwebuzima Vavi said the meeting unanimously rejected the latest hike because of its "devastating effects on the lives of all, especially the poor". The organisations supported the view that the increase amounted to collusion between the banks. He reaffirmed Cosatu's plan to march on July 6, but other

organisations would decide only once they had consulted their members. Cosatu would meet the SA National Civics Organisation soon to discuss its proposed one-week bank boycott.

Sasbo general secretary Graham Rowan said his union did not support the march call. Some Sasbo branches had criticised Cosatu's actions because they feared such a move could result in further job losses in the banking sector. A meeting in August would review Sasbo's position in Cosatu, Rowan said. SACP deputy general secretary

Jeremy Cronin said although the banks had been united in increasing interest rates, recent information suggested there was a tendency among them "to break ranks" as they were embarrassed that they had been "caught colluding". Vavi said there was no convincing argument from the banks or the Competition Board that collusion did not take place.

A National Labour and Economic Development Institute document, circulated at the meeting, said the recent increase was essentially to protect

banks' profit margins and rates would drop soon by one percentage point. This was partly due to political pressure on banks, "as well as the fact that the trade balance is improving and money market shortages are lessening". It proposed that short-term alternatives to hikes were banks absorbing the higher costs, the Reserve Bank lowering its rate thereby lifting banks' profit margins, and reducing the cash reserve for banks from 2% to 1%.

Picture: Page 2

SECTOR

Bank jobs up despite cost-cutting

(59) CT (MR) 25/6/96
By Sean Feely

FINANCIAL SERVICES EDITOR

Johannesburg — Local banks are employing more people even as they struggle to cut costs and improve their earnings from each employee, analysts said yesterday.

Earnings an employee are below international levels.

Employment levels at banking institutions and building societies' rose 6,3 percent year on year to 134 062 people in March, the latest month for which figures are available, from 126 115 in the same month a year ago, according to figures from the Central Statistical Service (CSS).

Average salaries and wages,

which include bonuses, declined 2,7 percent after being adjusted for inflation to R2754 a month in the first quarter this year, from R2829 in the same period last year.

Banks have been hiring more people as the financial services industry grows. Growth is sought to meet the needs of the so-called unbanked clients as well as to offer sophisticated products to existing clients.

Employment levels have also swollen as foreign banks entered South Africa and hired people for their local operations. The country's big four banks on average achieve earnings from each employee of about R32 500 a year,

with First National Bank (FNB) and Absa below the mean, Standard Bank slightly above it and Nedcor R10 000 above it. The average earnings from each employee is about four times higher in Australia and about 6,5 times better at British banks.

Earlier this year, Standard Bank offered 700 employees voluntary severance and retirement packages to reduce the cost ratio.

Nedcor, FNB and Absa, the other big banks, have stated their intentions to reduce costs and improve profitability ratios.

They have said they will achieve savings by cutting staff numbers and by increasing their business.

Employment figures up at money houses

Sowetan 27/6/96
(59)

By Isaac Moledi

EMPLOYMENT figures at financial institutions throughout the country have increased by more than six percent, says the Central Statistical Service.

As of March this year, more than 212 000 workers were employed at banking institutions, building societies and insurance companies. Compared to the employment levels at the end of March last year, this represents an increase of 13 504 workers or 6,8 percent.

Employment at banking institutions and building societies increased by 6,3 percent to 134 062 while numbers at insurance companies increased by 7,7 percent to 78 010 workers.

More blacks employed

The number of blacks employed showed the most significant increases - 21,2 percent in banking institutions and building societies and 19,4 percent in insurance companies.

Salaries, wages and bonuses for the same period amounted to R1,9 billion for banking institutions and building societies and R1,3 billion for insurance companies.

Real average wages and bonuses a month for banking institutions and building societies showed a decline of 2,7 percent from R2 829 for the first quarter of 1995 to R2 754 for the first quarter of 1996.

Insurance companies wages also showed a decline of 0,9 percent from R3 180 to R3 151.

BD 18/7/96

Union strike continues

ABOUT 70 SA Commercial Catering and Allied Workers' Union members picketed the PriceForbes insurance brokering company in Johannesburg for the third day yesterday.

A shop steward said the company refused to recognise trade unionism and workers would intensify their pickets if their demands were not met. He also said there were no affirmative action, transformation and training programmes in place, and that the company allegedly reserved senior positions for whites.

(52) (59)

White collar blacks affirmed

IN April 1993, the Absa Group renewed its efforts to address the fact that the racial make-up of their client base was not reflected in its staff. Absa now has a far-reaching and effective "constructive employment and development" policy.

It does not see its actions in terms of affirmative action, but rather as part of an on-going trend and a very necessary change process.

Bert Griesel, group general manager: human resources, notes that, unless the pool of qualified blacks is increased, then all South African companies will be competing for a limited number of candidates.

Consequently Absa, rather than employing untrained people as "tokens", have instituted grass-roots training schemes in order to increase the number of trained and qualified blacks.

Absa has an implementable programme surrounding their policy. No staff members will lose his or her job on the basis of their race or sex but, as the existing work-force diminishes through natural attrition, new employees are appointed to reflect the demographic make-up of the country.

"In April 1993, 16 percent of the Absa workforce was black. That figure has now risen to 25 percent and will continue to rise as the pool of qualified blacks increases," says Griesel.

There are numerous training initiatives which include a Candidate Bank Technician programme for people with matric but without any financial background. They are trained over a two-and-a-half year period during which time they may be employed permanently by Absa. At any one time there are 650 700 interns on the programme.

The Absa Group is one of the main sponsors of Alberton School which gives students from Standard 8-10 training in financial and business-related subjects.

One of the programmes Absa are most proud of is the training centre in the Africa Growth Network building. This is a walk-in computer training centre for unemployed people with 100 work stations and 250 students present on any given day.

The students undertake an 8-12 week course during which time they are taught computer literacy and software packages. Forty percent of the students are currently absorbed by the business market.

An innovative new programme involves the training of new tellers via satellite, an interactive television/computer system, whereby they can interact with the trainer from anywhere in the country.

The majority of Absa

employees belong to Sasbo, the finance union, which is affiliated to Cosatu. As the union mainly represents white collar workers in the banking industry, the affiliation has been challenging but Denise Mantle, consultant: industrial relations, says that members are positive about change.

Absa supports a philosophy of consultation whereby workers from all levels are encouraged to participate in decision-making process.

Two years ago, Absa instituted a Growth Charter which states the rights of employees. They include the right to "question the way we do things and propose changes which will ensure continuous improvement, in your team".

The relationship between the union and management is healthy. Absa's labour policies are fully negotiated with the union and the bank believes that when the new employment equity

legislation comes in, many of Absa's policies and practices will support the aims of the legislation.

In fact the only cloud on the labour relations horizon appears to be the issue of corporate clothing to women employees in the commercial banks while male employees do not have such a benefit. Judging by their other successes the company shouldn't have too much problem in sorting out this particular problem.



Bert Griesel ... for qualified blacks

WITH 34 FINANCIAL DIVISIONS

AT YOUR SERVICE

ISN'T IT TIME TO WEIGH UP YOUR OPTIONS?

From Fund Managing to Actuarial Consulting, from Corporate Banking to International solutions, the ABSA Group offers you the total spectrum of investment opportunity, in retail banking, wholesale banking and general financial services.

It's the least you can expect from one of the most comprehensive Financial Services Groups on the African Continent.

ABSA GROUP

AMALGAMATED BANKS OF SOUTH AFRICA LIMITED, REG NO 86/03934/06

Stals hits back at US bank's racism claim

Bank chiefs condemn 'blatant misinformation' in a confidential report, writes **Madeline Wackernagel**

THE Reserve Bank has hit back at accusations of racism, brought by Cosatu at last week's bank collusion hearings and based on a confidential report by CS First Boston.

Says deputy governor, Dr Timothy Thahane: "I took up my appointment in April, some time after Mary Davis of CS First Boston visited this country and wrote her report, so I was not privy to any discussions she may have held with bank representatives.

"Her opinion that the bank is opposed to affirmative action is wrong; policies have been in place for some time, although implementation has lagged behind."

The governor, Dr Chris Stals, has written to the president of the New York investment bank, condemning the report in the strongest terms: "I cannot but strongly object to this kind of blatant misinformation being distributed to potential investors in South Africa. I was not in the country at the time of the visit of Ms Davis, but all my efforts to locate anybody in the Reserve Bank who may have

granted her an interview failed."

Attempts to contact Davis proved fruitless but her original report said: "They [the bank] are critical of affirmative action employment policies, even though blacks are utterly under-represented at the bank, on the grounds that not enough skilled blacks are available, although they have not implemented a training programme."

Thahane was quick to refute this criticism: "There are three top black executives, plus myself, and others at a more junior level.

'Dr Stals has assured me that there are no constraints on a budget for training and we are planning to link up with various other central banks'

We have a training programme — eight cadets have graduated from the two-year course, which entailed a period in each department. Of these, one has gone on to complete a doctorate, another has left. But the others are staying in permanent positions.

"When I joined the bank, my aim was to push ahead with affirmative action policies and that's exactly what I'm doing. In terms of the bank's written policy, there was little I could add, but implementation has not been as rapid as hoped. We are now-

ing to change all that, and by this stage next year we will be in a position to report concrete progress."

The appointment of Thahane was seen as a step in the right direction by disgruntled bank staff, but the process has been too slow to counter all complaints, says an insider.

Says Thahane: "Any change in an institution like ours is not easy and anxieties are understandable. But we have to make sure that we employ the best people to the best of their abilities.

"Basically, it is now a question of training, otherwise we run into problems of performance. But Dr Stals has assured me that there are no constraints on a budget for training and we are planning to link up with various other central banks, such as the Bank of England, to enhance our training programme.

"Top management has to give the affirmative action plan special attention. We now have a succession plan in place for all levels of management, and managers are responsible for ensuring that previously unrepresented groups are carefully considered. Any managers that don't actively participate in meeting these objectives will be moved out."

Stals was also quick to dispel the doubts cast by Davis on the bank's loyalty to the government and the Reconstruction and Development Programme (RDP): "It is also just not true to say that 'The bank is critical



Dr Timothy Thahane: His appointment was seen as a step in the right direction by Reserve Bank staff

of the RDP and its goals'. Anybody who may have read through the many references I made to the RDP in public speeches ... will know that the bank has never criticised the RDP and its objectives."

But once the story of the confidential report had broken, Davis back-

tracked from her initial tough stance towards the bank. She was quoted as saying: "I believe the Reserve Bank has been acting in the best interests of the economy at all times ... absolutely and utterly crucial that the bank have the freedom to operate independently."

FNB chief must go - Saccawu (59)

Swemtan 28/8/96

THE South African Commercial, Catering and Allied Workers' Union yesterday called for the resignation of First National Bank managing director Barry Swart.

At a media briefing in Johannesburg, Saccawu official Sthembela Tshwete accused Swart and other FNB managers of nepotism.

Tshwete said the fact that the bank had censured Swart for awarding a family member a tender worth more than R6 million necessitated his resignation.

"The Swart move has actually evoked a lot of anger among union members and also confirms employees' claims that there is a lot of nepotism swelling among the ranks of FNB management."

The union wanted an independent inquiry into the nepotism claims because members had information which could assist such an inquiry.

Saccawu also reported a deadlock in wage negotiations with Sun International management. National organiser Bongani Madikiza said 7 000 employees of the hotel group were preparing to go on strike if the parties fail to reach agreement at a meeting scheduled for Thursday.

Said Tshwete: "We are ready for any action at any time. - Sapa.

The knives are out for bank's MD

(59) M+G 30 | 8-5 | 9/96

Max Gebhardt

SENIOR management at First National Bank (FNB) are worried about the future of lucrative provincial government banking accounts because its managing director Barry Swart is widely perceived as guilty of nepotism at worst and foolishness at best.

Senior management fears were compounded by calls this week from the South African Commercial, Catering and Allied Workers' Union (Saccawu) for Swart's head to roll and for a commission of inquiry to investigate allegations of nepotism within the bank.

The governments banking accounts are due for renewal in 1998. Latest figures from the Reserve Bank show FNB is also losing market share.

Some senior staff believe Swart is bringing FNB's name into disrepute and he is "misplaced in the current times".

Swart was censured by the bank last week after an internal investigation found he had given his daughter, Tanya Labuschagne, a contract to help decorate Bank City, FNB's headquarters in Johannesburg.

The investigation was sparked by anonymous allegations which were circulated within FNB senior management three months ago.

It later emerged his other daughter, Kim Swart, was employed by the bank's external marketing and communications agency.

Staff at FNB, who spoke to the *Mail & Guardian* on condition of anonymity, said the knives were now out for Swart. All those canvassed

believed Swart should go.

Many see Swart as a major stumbling block to the transformation of the bank and consider him a "bit-terende" who won't join the new South Africa. An allegation also levelled at Swart by the unions.

This, they fear, could see FNB lose its 70% share of the provincial government accounts.

"The board has shown a complete lack of resolve, they should have given leadership without fear or favour. This has placed the whole integrity of the bank under the spotlight," a senior manager said.

He added that staff were also concerned about the role other senior members in the bank had in awarding the contract to Swart's daughter and questioned why they had not yet been named.

Swart is described as a "tin-pot dictator" by some staff.

Junior staff members told the M&G they wondered why senior management was not subject to the same stringent disciplinary standards they had to conform to.

"The board has no backbone. This is very demoralising," one said.

There is also increasing disquiet from within and outside the bank that this could be the start of a rash of allegations of corruption and nepotism at FNB.

There was some concern at senior management level about the awarding of various service contracts by the bank's tender board.

Others in the banking sector believe there has been a deliberate campaign to discredit Swart and see his role in his daughters' connections to the bank

as no more than "bloody foolhardy".

Swart has doggedly refused to talk to the media other than with a written statement published in *Business Day*, in which he said he regretted his "insensitive" action in employing his daughter and acknowledged he had caused the bank embarrassment.

Graeme Rowan, general secretary of Sasbo, the 75 000 strong finance union, said: "He has done himself a disservice that has severely damaged his credibility and reputation in the eyes of the union and the bank's staff."

Richard Wilkinson, executive director of the Institute of Directors, said censure by the board (as happened in Swart's case) was serious and would have been recorded in the company's minutes. According to Wilkinson, this is far more serious than a letter of warning which the trade unions have been calling for.

At the time of going to press Swart's office had not yet responded to questions by the M&G.

Staff call on Swart to resign, FNB board accused of 'letting him off the hook'

By **TROYE LUND**

First National Bank staff have called for the resignation of their managing director Barry Swart after finding out through the Internet that his directors had warned him about alleged nepotism. The warning referred to the

lucrative decorating contract for the bank's headquarters, which Swart awarded to his daughter Tanya Labuschagne's company. Swart issued a brief statement last night in which he referred to an investigation into the matter by two independent board members, Meryn King and Robbie Williams.

Star 23/8/96

"I accepted the findings that I had acted insensitively in some areas and was duly censured for this. "I stress that the bank suffered no financial loss. I acknowledge that there has been embarrassment to FNB and I regret this," he said. In an earlier statement, King

said the bank had suffered no financial loss as a result of Swart's actions. The fees paid to Labuschagne were market related, so he had not been asked to resign. But the SA Society of Banking Officials (Sasbo) expressed shock and dismay at the way Swart

... To Page 2

(59)



Swart ... accepted findings that he had acted insensitively

Staff call on Swart to resign

(59)

From Page 1

had been "let off the hook". Sasbo is the country's biggest banking union, with 75 000 members. It represents more than 70% of FNB's 30 000 employees.

Sasbo secretary-general Graeme Rowan said union members had lost jobs in the past for less serious transgressions.

He added that Swart's "highly dubious" actions had destroyed his credibility and reputation among staff.

"That there was no financial loss is not the issue to judge him on. It is the morality of it."

"FNB must deal with the matter in terms of the disciplinary code applied to staff generally."

Several senior FNB managers at Bank City, who are members of the union and who spoke to The Star yesterday, agreed, saying the "honourable" thing for Swart to do was resign.

"The whole thing is shocking. We would never have found out if someone had not spotted it on the Internet.

"What confidence are we to have in him now?" said one manager, who asked not to be named. He has been with the company for 20 years.

Another manager, who preferred to remain anonymous, said the whole of Bank City was "buzzing" with the news.

Star 23/8/96

FNB comes under fire

~~ES~~ (69)
Adrienne Giliomee

BD 27/8/96
FIRST National Bank had failed to impose the same discipline standards on its executives that it imposed on the rest of its work force, banking union Sasbo said yesterday.

The union, which represents more than 70% of the bank's employees, said many of its members had been fired for offences far less serious than those pinned on MD Barry Swart.

Swart was censured by the FNB board last week for employing his daughter to help decorate the group's Bank City headquarters. His other daughter is a partner in a marketing and communications agency used by the bank.

Union says FNB's MD Swart must go

80 28/8/96 (59)

Reneé Grawitzky

THE SA Commercial, Catering and Allied Workers' Union (Saccawu) has called for the resignation of First National Bank MD Barry Swart and an independent inquiry into nepotism in the company and the R6,3m contract awarded to Swart's daughter to refurbish Bank City.

Saccawu publicity officer Sithembele Tshwete said yesterday that recent revelations around Swart confirmed the union's earlier suspicions and allegations that top management at FNB were promoting nepotism and such practices had "swelled the ranks of management".

The union demanded that the findings of the FNB investigation into the incident be made public, and it also called for an independent inquiry to look at nepotism in the company.

Tshwete said the union would be prepared to give evidence at an inquiry and was in the process of gathering information on the extent to which nepotism was being practised.

Tshwete said the union had obtained certain documents, one containing an acknowledgement by the bank that if Saccawu was recognised a "lot of things would be uncovered".

A union source within FNB said an internal plan prepared by the bank's industrial relations department highlighted the union as a "flashpoint" and indicated there would be "chaos in the bank" if the union was recognised. The source said the plan indicated management should be careful of the union.

Union sources indicated that a lot of people were frustrated with the fact that Swart was opposed to transformation in the bank and had blocked change, and possibly the release of the information on his daughter was an attempt to discredit him. Bank sources said several allegations against Swart had been investigated in the inquiry by non-executive directors Mervyn King and Robbie Williams.

Meanwhile, the union outlined further strike plans at Sun International in the wake of the disruption at all operations at the weekend. The union said the company could face action at "any moment". The union said action could occur prior to a planned meeting tomorrow with the company.

The union also indicated that workers at Joshua Doore and Edgars would be balloted for strike action during the first week in September. Saccawu said the deadlock with Edgars revolved around wage differentials.

Bank chief quits in contracts dispute

(59) ARG 10/9/96

ARGUS CORRESPONDENT

Johannesburg – The 40-year banking career of First National Bank managing-director Barry Swart will come to an abrupt end today because of the discovery by the board that he awarded decorating contracts for several million rands to his daughter.

This follows an announcement by FNB chairman Basil Hersov yesterday evening after talks between Mr Swart and the board. Mr Hersov said the board had accepted Mr Swart's request for early retirement.

A statement on management continuity and possibly the name of his successor will be released today.

Bank spokesman Alec Grant would not disclose details of the package, saying it would be negotiated according to salary. Several people at the bank have indicated that Mr Swart earns R1,6-million a year.

Mr Swart awarded decorating contracts for the bank's Johannesburg headquarters to his daughter, Tanya Labuschagne.

Last night Mr Swart said that in spite of his publicly expressing sincere regret for any embarrassment he had caused the bank, it appeared there had been "an erosion" of confidence in him.

He feared that this, as well as the current public debate over his credibility, could result in prejudice to the bank, its staff and shareholders.

"In the best interests of the bank and as the proper action for a person in my position, I should take early retirement," he said, and thanked his staff, colleagues and business associates for their support.

Staff at FNB's Bank City headquarters said Mr Swart should have resigned as soon as the decorating contracts were made public last month.

One manager said: "We need some new blood. There have been many rumours for years about these contracts and many other things.

"The morale among staff has been low. People feel ... many top managers can't be trusted," he said.



Barry Swart, former First National Bank MD.

FNB's Swart quits after controversy

(59) BD 10/9/96

Adrienne Gillomee

FIRST National Bank MD Barry Swart resigned yesterday, saying his censure by the FNB board could hurt the bank, its staff and shareholders.

Swart, who was appointed MD in 1989 and has a contract until 1999, said he would take early retirement following lengthy board meetings at the weekend and yesterday.

No details of his retirement package were given, but chairman Basil Hersov said Swart's departure had been discussed for some time. Swart, who turns 56 next week, had offered his notice.

Hersov said the board would meet today to discuss Swart's successor, but declined to be drawn on candidates.

Sources tipped senior GM Johan Meiring and executive directors Viv Bartlett and Peter Thompson as contenders. JSE president Roy Andersen was also touted, but Andersen dismissed this.

Swart's departure follows the disclosure last month that the board had

stopped just short of dismissing him after an internal probe found he had awarded his daughter, Tania Labuschagne, a R6.3m contract to redecorate the bank's headquarters at Bank City. The bank had suffered no financial loss, the investigation directors Mervyn King and Robbie Williams also looked into other allegations. Swart's other daughter, Kim Swart, works for the bank's external marketing and communications agency.

Swart said he had "publicly expressed my sincere regret for any embarrassment" the censure had caused FNB. "Views have been expressed that there has been an erosion of confidence and thus my credibility has been the subject matter of public debate.

"This could well result in prejudice to the bank, its staff and its shareholders which I would not wish to incur ... I have decided that in the best interests of the bank and as the proper action for a person in my position I should take early retirement ... I will be standing

down as MD with immediate effect."

Anglo American, which with De Beers is FNB's controlling shareholder, declined to comment yesterday.

Following the disclosure of the board's censure, however, Anglo had said it was "satisfied ... that nothing will be done or should be done regarding Swart's position at FNB."

Hersov said the board thanked Swart for the "valuable role" he had played as MD.

Swart's departure is the third case of the bank losing its chief in controversial circumstances. Predecessors Chris Ball and Bob Aldworth departed earlier than their contracts stipulated.

Finance union Sasbo, which led much of the opposition to FNB's initial handling of the issue, said yesterday the bank had acted correctly this time. General secretary Graeme Rowan said Swart should have set an example. It was a sad end, however, to an outstanding career at FNB, he said.

See Page 13

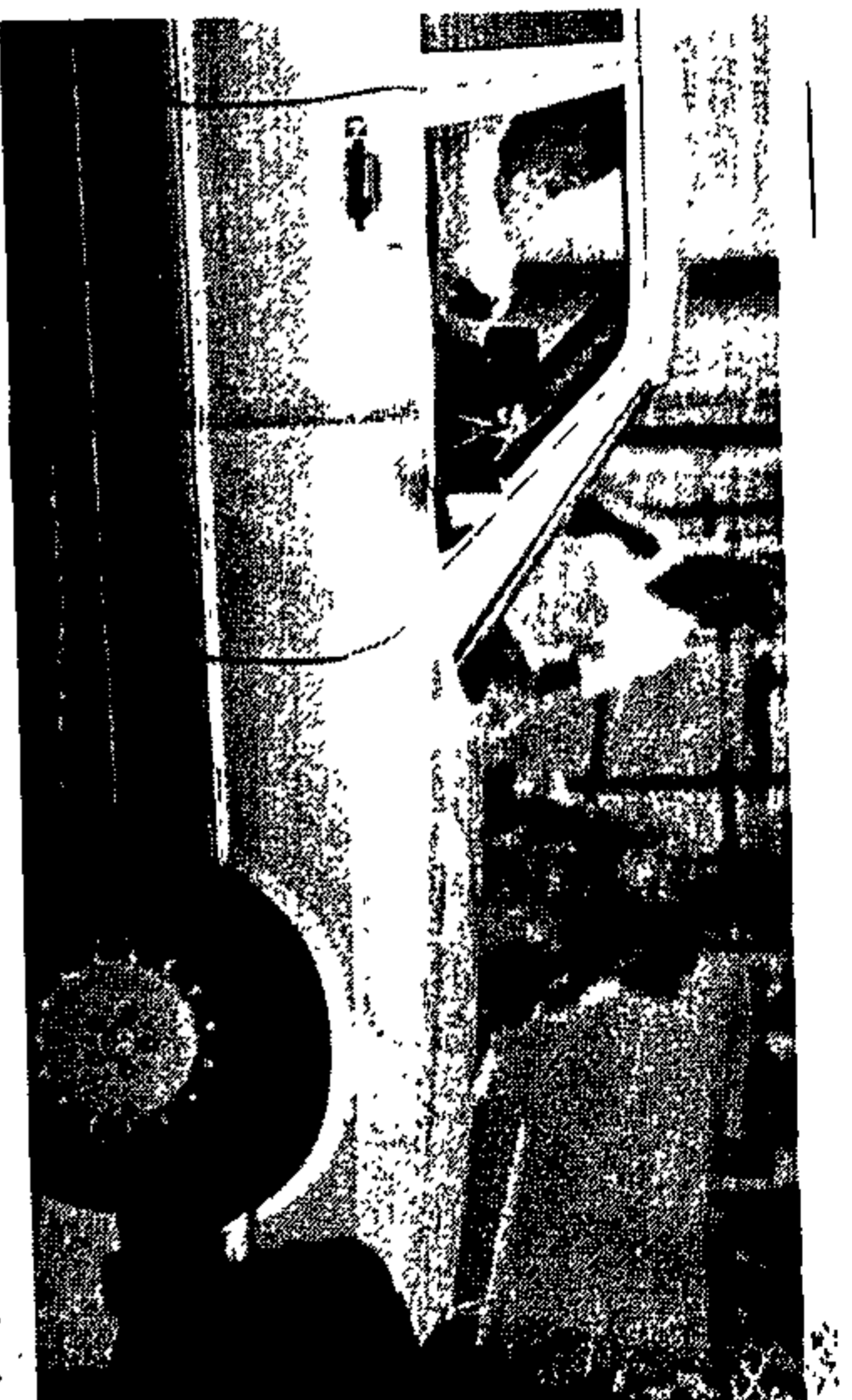

First National Bank MD Barry Swart drives from Bank City headquarters in Johannesburg yesterday, soon after announcing his resignation. Picture: TRONEARTHUR

State closes case in Malan murder trial

BD 11/9/96

DURBAN — The State believed it had proved beyond all reasonable doubt that former defence minister Gen Magnus Malan and 13 of the other accused in the KwaMakutha massacre trial were guilty of murder, KwaZulu-Natal attorney-general Tim McNally said yesterday.

He was presenting the State's final argument in the trial of 17 people accused of murder, attempted murder and conspiracy to murder arising from an attack in 1987 on the KwaMakutha, Amanzimtoti, home of UDF activist Victor Ntuli.

The attack was allegedly carried out by Inkatha members who received paramilitary training from the SA Defence Force.

Ntuli was not at home at the time of the attack and 13 other people were shot dead, most of them women and children.

Yesterday McNally told Judge Jan Hugo the state did not believe former military intelligence officer Cmdt Jan van der Merwe's denial of evidence that after the massacre he collected the AK-47 rifles used in the attack and took them to Pretoria for smelting.

However, the State was not in a position to ask for him to be convicted on any of the charges McNally also said there was not sufficient cogency in the evidence against two alleged members of the murder squad, Hloni Andreas Mbuyazi and Alex Vulindlela Biyela, for them to be convicted on the main charges of murder and attempted murder.

However, the State believed it had proved they were guilty of conspiracy to murder. Mbuyazi and Biyela are among six alleged members of the murder squad in the dock.

The trial is continuing. — Sapa.

Liberty's court bid to bar retrenched workers is postponed

Deborah Fine

MORE than 300 retrenched Liberty Life Properties employees gathered outside the Rand Supreme Court yesterday to oppose the finalisation of an interim court order barring them from entering or protesting outside Liberty's upmarket Sandton City, Eastgate and Alberton shopping centres.

The matter was postponed yesterday.

day to September 17 to allow the workers — mostly members of the SA Catering, Commercial and Allied Workers' Union — to file opposing papers.

The interim order, granted on Thursday night, interdicts the union and 310 former Liberty employees from entering or occupying the shopping centres, congregating or demonstrating within a radius of 500m from the centres, obstructing access to the

SA Commercial, Catering and Allied Workers' Union officials and more than 300 retrenched Liberty Life employees gather outside the Rand Supreme Court yesterday to oppose the finalisation of a court order barring the workers from protesting outside Liberty Life properties.

Picture: TREVOR SAMSON



premises as well as interfering with customers, contractors, other Liberty employees and centre tenants.

In papers before court, Liberty said the company and the union had negotiated an agreement in April this year whereby Liberty was to proceed with the rationalisation of four divisions. Notices of termination of employment had been issued to all affected employees, but in breach of the settlement

reached they had attempted to continue their duties in September.

Meanwhile, former Liberty regional development officer Tony Katsapas, who is suing Liberty for R750 000 on the grounds of unfair dismissal in 1994, toyi-toyed with the workers outside the court yesterday. He said he and the workers would continue to picket outside Liberty's properties until both matters had been resolved.

(59) BD 11/9/96

Banks buck trends by employing more staff

(59) ET(BR) 24/9/96

By Nancy Myburgh

MARKETS EDITOR

Johannesburg — Employment at South Africa's financial institutions rose by 7,1 percent, or 14 271 people, between the end of June last year and this June, the Central Statistical Service (CSS) said yesterday.

This comes in spite of reports earlier this year of plans by some of the country's major commercial banks either to reduce staff numbers through attrition or voluntary retirement packages, or to keep employment static.

"Basically, (our growth over the past year) has been in new initiatives," said Ashley Sutton-Pryce, the assistant general manager of human resources at Nedcor Bank. "(But) we've certainly seen a leveling off in recent months."

Louis Moll, the assistant general manager for industrial relations and support services at First National Bank, said: "We had fairly steady growth across the board, but recently we have put a stop to that, as we are having a relook at our staff numbers."

The CSS figures revealed that banks and building societies had recorded an annual increase of 5,9 percent in employment over the period, or just over 7 500 people, while insurance companies recorded an annual increase of 9,3 percent, or slightly more than 6 700 employees.

Of the different population groups, the number of new black employees showed the largest annual growth, with a 16,4 percent increase at banks and building societies in the period and a 19,5 percent increase in numbers at insurance companies.

The number of new white employees showed the smallest annual employment rise, with just 0,3 percent more people employed at banks and building societies and 3,8 percent at insurance companies.

The number of coloured employees showed an annual increase of 16 percent in banks and building societies and 8,8 percent in insurance companies.

Asian employment grew by 13,1 percent in banks and building societies and by 7,7 percent in insurance companies.

Finance sector staff ahead in salary race

ST (BT) 29/9/96

Hay Management Consultants' salary survey has some surprising findings.

DON ROBERTSON reports

WORKERS in the industrial and financial services sectors should be smiling. Not only were salary increases in the comparable period last year, they were well above the inflation rate for all levels of staff.

Executive increases were significantly better than in previous years and, for the first time

in many years, the financial services sector, including banks and financial institutions, gave increases above that of the industrial sector.

Traditionally, salaries are higher in Gauteng than in other provinces, but this year's Hay Management Consultants' annual remuneration survey shows that this is no longer the case for all levels of employment.

Hay Management survey manager Ivor Solomon says salary packages for professionals and junior level management in the finance sector tend to be lower in Gauteng than in KwaZulu/Natal, the Western

Cape or the Eastern Cape, whereas the trend is reversed for all other levels of staff.

Surprisingly, in the industrial sector salary packages as a percentage of the national average are higher in areas outside Gauteng. Solomon believes that a company in East London, for instance, threatened with losing a senior executive, would be prepared to increase the salary to retain the employee. In Gauteng, an executive is easily replaced.

In the industrial sector salary packages are higher in areas outside Gauteng

The "ability to pay" is described as the most important factor in establishing salary increases, followed by the level of profits, the cost of living in an area and the business outlook. With multinationals, the parent company's view of the future in South Africa was a consideration.

Following the downsizing in the industrial sector last year, staff turnover dropped to 10% from 11%, but increased sharply in the finance sector to 16% from 11% in 1995.

The survey shows that increases in car allowances have

been substantially higher than the consumer price index, which is considered strange since car price increases have been kept to a minimum because of competition.

Lower-level employees have traditionally paid a larger percentage of their base salaries to medical aid contributions, compared with management and executives. Over the past two years the scenario has changed, with general workers paying less as a percentage and executives more.

Generally, purchasing power at all levels came down substantially between 1991 and 1995, but because of higher increases last year purchasing power has recovered to some extent.

BOEREWORS AND BEER INDEX

WHAT EXECUTIVES CAN BUY WITH 1 YEAR'S SALARY

	1991	1992	1993	1994	1995	1996
Cans of beer	90 961	67 531	72 661	72 652	64 229	75 947
Kilograms of boerewors	8 823	9 925	10 653	9 708	9 229	11 100
Golf	3,25	3,0	3,08	2,91	2,89	3,18
Mercedes-Benz 230E	0,76	0,71	0,70	0,68	0,70	0,89

WHAT STAFF CAN BUY WITH 1 YEAR'S SALARY

	1991	1992	1993	1994	1995	1996
Cans of beer	19 336	20 402	12 468	11 958	10 895	11 732
Kilograms of boerewors	1 874	1 847	1 828	1 620	1 553	1 719
Golf	0,7	0,55	0,53	0,49	0,48	0,49

PAY DIFFERENTIALS BASE SALARY

	General worker : Clerical/supervisory 100 : 300	General worker : Management 100 : 600	General worker : Senior management 100 : 1000	Executive 100 : 1500
1996	2,8	5,6	9,6	14,4
1995	2,5	4,8	7,9	10,8
1994	2,5	4,5	7,4	10,6
1993	2,5	4,8	8,0	10,8
1992	2,4	4,5	7,2	9,8
1991	2,5	4,5	7,3	9,9
1990	2,3	4,8	7,9	10,8

Graphic HONA KRISCH

Source: HAY MANAGEMENT CONSULTANTS

CRIME *Internal fraud said to be rife*

Insurance group uses lie detector on staff

(59) (C) (BR) 9/10/96

NANCY MYBURGH

FINANCIAL SERVICES EDITOR

Johannesburg — Internal fraud in the insurance industry is so rife that the Hollard Insurance Group now requires selected new employees to take polygraph, or lie detector, tests, Miles Japhet, the managing director of Hollard, said yesterday.

Japhet said Hollard had instituted stricter internal controls over the past year because there was considerable opportunity for insurance company personnel to help inflate insurance claims fraudulently and skim off a profit in the case of a vehicle hijacking or if someone had been involved in an accident.

"All new employees who handle money undergo a polygraph test. We (also) use random telephone conversation taping.

"That is where you get the opportunity to pick up collusion. Unfortunately, you have to wage war against internal fraud, and (you must) not be naive.

"But it is our duty. We cannot keep having honest clients pay the costs of fraudulent claims through higher premiums," he said.

Given the average Hollard

claim assessor's workload and pay scale, Japhet estimated that a 1 percent inflation of a month's claims could afford fraudulent gains equal to a month's salary.

But the cost savings from greater control of internal fraud, as well as more efficient risk management, had allowed Hollard to reduce clients' insurance premiums in certain kinds of policies by about 10 percent, he said.

Another large insurer said yesterday that his firm did not go as far as Hollard in detecting internal fraudsters.

"We have checks and cross-checks. . . . Our major control is drumming into staff that they have to adhere to the controls and that checking procedures are in place.

"That is part of our ethos," he said.

However, "it is difficult to pinpoint where we've been successful and where the gaps (in internal fraud detection) are," he said.

Hollard is a privately owned insurance group, whose gross written short-term premiums increased 47 percent in the year to March 31. Japhet said they were projected to exceed R800 million in the present financial year.

**RETRENCHMENTS SPARK DEMO AT
CHAMPIONS TENNIS TOURNAMENT**

Johannesburg – A festive crowd that packed the tennis stadium for the MTN Champions Tournament at Sandton Square shopping centre were completely oblivious to a (69) demonstration just 100 metres away as a police dog squad dispersed about 150 protesters.

ARG 17/10/96
The South African Commercial, Catering and Allied Workers Union demonstrated to draw attention to the plight of 250 employees retrenched earlier this year by Liberty Life Properties, which has a stake in the Sandton City shopping centre. – Argus Correspondent

LABOUR Retrenched workers told to sign indemnifying forms before being paid

Police oust Liberty protesters

(59) CT(BR) 17/10/96

JONATHAN ROSENTHAL

Johannesburg — Liberty Life Properties is trying to force retrenched workers to sign forms indemnifying the company against any claim arising from their retrenchment before it will hand over money owed to them from the sale of shares and share options.

About 200 of the retrenched workers yesterday protested against the company's actions at the Sandton Square shopping centre, where the MTN Champions tennis tournament is taking place, before being forced away by the police.

Documents in the possession of Business Report show that retrenched workers who qualified for share options while in the employ of Liberty Life Properties would have to sign the indemnity form before they would be handed cheques for the proceeds of the sale of these shares or share options.

The form states that workers who accept cheques do so "in full and final settlement of all disputes between myself and Liberty Life Properties", and that the transfer of benefits from the Liberty Life Pension



CLAIMS Anthony Katsapas, a Liberty Life employee who was fired in 1992 for what he alleges was whistle-blowing about irregularities in the company, joins workers retrenched from Liberty Life Properties in a protest at the Sandton Square shopping centre yesterday PHOTO: JOHN WOODROOF

Fund will be dealt with separately from this agreement.

About 350 workers, members of the South African Commercial Catering and Allied Workers' Union, were retrenched by Liberty Life Properties at the end of August when the company outsourced

cleaning and security functions. But retrenched workers and union officials alleged that Liberty guaranteed to ensure that they would be hired by sub-contractors. Joseph Mosi, a union official, further alleged that Liberty Life had withheld provident and pension fund monies

owed to the retrenched workers. Karen Mitchell, a director of Liberty Life Properties, declined to comment on the specific union allegations regarding the payment of pension and provident funds and the company's alleged undertaking to guarantee workers their jobs.

Direct sale of fresh produce opposed

Louisa Cook  01 3110196

THE R2.5/tn-a-year fresh produce industry would strongly oppose direct sales between farmers and wholesalers at SA's 17 fresh produce markets, as this would cut out the need for market agents, National Fresh Produce Forum president Bertha van Zyl said yesterday. Wholesalers of fresh produce were keen to operate from market premises as this guaranteed readily available buyers. But attempts to avoid paying commission would be opposed, as this would undermine the market agent system.

Market chief Hannes Rademeyer said the Johannesburg metropolitan council — owner of the City Deep market — received 25 applications from wholesalers to operate directly from the market. These included King Fresh, Nayan Bros, Rahmeguys and Govan Naha.

Various sources said plans to accommodate the applicants in a specially allocated area at the market had been delayed due to the council's restructuring following last year's local elections. However, if earlier proposals were accepted, special infrastructure would be created to accommodate the new players.

Most produce markets were owned by former city councils which charged a commission on turnover to market operators and farmers. Wholesalers were unavailable for comment.

Error could hold up court battle with Liberty workers

Deborah-Fine  (59) 80 3110196

ATTEMPTS by Liberty Life Properties to finalise a continuing court battle with 310 retrenched employees could be delayed after it was discovered yesterday that the firm had erroneously included former Liberty regional development officer Tony Katsapas as a respondent in the matter.

The company first obtained an interim interdict in the Rand Supreme Court on September 5 which barred the dismissed workers — most of whom are members of the SA Commercial, Catering and Allied Workers' Union — from entering or congregating near Liberty's Sandton City, Eastgate and Alberton shopping centres.

The workers, retrenched after Liberty Life Properties outsourced its cleaning and security divisions, claimed they had gathered outside the shopping malls in protest because the firm had failed to make good an alleged guarantee that dismissed workers would be rehired by subcontractors.

Katsapas, who has sued Liberty Life for R750 000 on the grounds of unfair dismissal in 1994, toyi-toyed with the workers outside the court, saying he was supporting their cause because they and Saccawu had "sympathised" with his. He was not named as a respondent in the original interdict.

Liberty Life Properties returned to court again on September 26 to have the original

interdict amended to ban the workers from also gathering outside Liberty's head office in Braamfontein, and at the Sandton Square shopping centre. The matter was postponed again to allow the workers to file answering papers.

The firm then launched a second urgent application on October 18 to bar the workers from gathering outside the homes of Liberty Life management after, it was alleged, they had congregated outside the house of Liberty Life MD Donald Gordon, and refused to let him leave the premises.

Katsapas was in the crowd outside Gordon's home and also part of a Saccawu demonstration at Sandton Square on October 16 to coincide with an international tennis tournament. The demonstrators were forced away by police. Katsapas had now been cited as a respondent in the matter in his personal capacity, as well as in a further pending application to have the workers imprisoned on charges of breaching the amended interdict prohibiting them from entering Sandton Square.

In Liberty's application to have the interdict made final yesterday, Judge PJ Schabert said Katsapas had not been given proper notice of Liberty's intention to include him as a respondent in the proceedings. Schabert said he could not allow the matter to continue until there had been compliance with proper procedures.

Union wins interdict against Boland Bank for alleged victimisation

Reneé Grawitzky

UNION confederation Cosatu's financial union, Sasbo, yesterday applied to the Cape Town Labour Court for an urgent interdict to prevent the alleged victimisation of its members by Boland Bank.

The union argued that after it had declared a dispute with the

bank for its alleged failure to consult properly on the introduction of extended trading hours, its members had been victimised.

The court ordered the bank's employees to continue working extended trading hours pending a further hearing on February 7.

Boland Bank launched the new system on December 2.

The court also ordered the bank to meet Sasbo today to discuss its request for organisational rights in terms of the new Labour Relations Act.

Sasbo regional secretary Charles Wells said that until yesterday Sasbo officials had not been welcome on any Boland Bank premises. "This order guarantees

that no union member will lose their Christmas bonus or other benefits. The bank advised the union that anyone who supported the dispute would forfeit these benefits," he said.

Boland Bank countered that it had consulted extensively and that it enjoyed the overwhelming support of its employees.

Bank spokesman Chris de Beer said most of Sasbo's members did not back the dispute. "There is widespread appreciation of the bank's innovation to make banking hours more accessible to clients. The more competitive and profitable the bank is, the better the future we can offer our employees," he said.

(59) 206/11/96

Union takes bank to court over longer trading hours

Bid to resolve dispute by negotiation

ARAG 6/12/96
(59)

ESTELLE RANDALL
LABOUR REPORTER

Boland Bank's introduction of longer banking hours last week has raised the ire of employees and their trade union - who claim they were not consulted.

Sasbo-Finance Union yesterday also asked the Labour Court to compel the bank to grant it organisational rights in terms of the the new Labour Relations Act.

The case was the first in the Western Cape to come before the Labour Court, a new dispute-adjudication body established by the Labour Relations Act, which came into operation last month.

Yesterday the Labour Court ordered

employees to continue working the extended hours until the issue is resolved by negotiation over the next six weeks between Boland Bank and the Sasbo-Finance Union.

If it is not resolved through negotiation by February next year, the court will make a ruling instead.

Boland Bank was ordered to meet the Sasbo-Finance Union today to discuss the union's request for organisational rights under the new Labour Relations Act.

The court also ordered Boland Bank to restate its support for freedom of association and employees' right to join a trade union of their choice, not to condone victimisation or intimidation of trade union

members and to discipline anyone guilty of victimisation. Boland Bank must fax a copy of the court order to all its branches by close of business today.

On December 2 Boland Bank began to stay open for business until 5.15pm for the convenience of the public.

But the Sasbo-Finance Union says employees were led to believe that the increase in working hours to 174 a month would give them greater freedom to arrange their own working hours. Instead, the longer hours meant bank employees left work an hour later.

The new hours will cause problems for employees' child care, transport and other arrangements, the union says.

Bid to shut door on longer banking hours

FINANCIAL SERVICES
By HEATHER FORMBY

BOLAND Bank's innovative decision to extend its banking hours as part of a more customer-driven approach may be thwarted by the industry trade union.

On Monday the bank extended its trading hours in all its 88 branches, two thirds of which are located in the Cape. Instead of closing at 3.30pm during the week and 11am on Saturdays, Boland outlets are now open to 5.15pm on weekdays and from 8am-1pm on Saturdays.

The finance industry union, Sasbo, declared a dispute with the bank, claiming its management had acted unilaterally. Boland court tested the dispute in Cape Town's labour court on Thursday on the basis that it had consulted extensively with employees. "We held 40 different communication sessions with staff," says marketing head Chris de Beer. However sources say the dispute goes be-

yond extended working hours at Boland alone.

"It's a result of staff from other banks trying to avoid the possibility of working longer hours. Also, Sasbo wants to increase its membership at Boland," a source says. A court order postponed the union's application to February 7. Boland says all staff will continue to work the longer hours in the interim.

Managing director Michiel le Roux says the bank is striving for a more client-orientated approach. "In the past, banks focused only on risk. Now we are re-focusing to become client-driven without neglecting risk management."

It is unlikely other banks will follow suit. A Standard Bank spokesman says the bank constantly re-examines customer requirements

but has no plans in the short-term to extend banking hours. "We already provide a number of after-hours services in the form of electronic and telephonic banking."

Nedbank has made no decision on the issue, but does have a number of outlets in supermarkets which are open store hours for personal banking requirements.

Absa says its research shows that customers don't want longer banking hours, but that it will re-examine the issue on a local, rather than a national, basis.

Today's banking hours are relics from the past. In the old days, balancing the day's books was done by hand so banks had to close to give staff time to complete this exercise before they went home.

Now computers are able to do the job far more rapidly.

ST (BT) 8/12/1986

Financial sector hires more blacks



CHRISTO VOLSCHENK

CTCPR 12/12/96

Cape Town — The blackening of the workforces of banks, building societies and insurance companies is proceeding apace.

According to the Central Statistical Service, 18 percent of building societies and banks' employees, and 21 percent of insurance companies' employees were black at the end of the third quarter, up from 16 and 19 percent last year.

Whites made up 61 percent of banks and building societies workforces, down from 65 percent, and 59 percent of insurers' workforces, down from 60 percent.

At the same time, banks and insurance companies employed more people. The workforce at banks increased from 124 000 to 130 000 and insurance companies' workforces from 72 000 to 75 000.

Union and Boland resolve dispute over banking hours

MARC HASENFUSS

Cape Town — Boland Bank and Sasbo, the Finance Union, have resolved their disputes around longer working hours and organisational rights, a joint statement released last night said.

Sasbo has agreed that all disputes with the bank be withdrawn from the Labour Court and the Commission for Conciliation, Mediation and Arbitration.

Sasbo declared a dispute when Boland Bank extended its banking hours in December last year to an average 43 percent longer than other banks in South Africa. The bank stretched its working hours from 3.30pm to 5.15pm on weekdays and from 11am to 1pm on Saturdays.

The new hours meant employees would, on average, work 3.2 percent longer on a shift system and would be com-

pensated proportionately.

According to the agreement hammered out by the parties yesterday, Sasbo will ballot its members to ascertain any further problems with the change in working hours.

If any problems are identified, Boland Bank will "individually" explore solutions acceptable to both parties. But if agreement is not reached by March 31, the individuals con-

cerned would revert to their previous working conditions.

Boland Bank and Sasbo also agreed that the union would be granted organisational rights within the bank as its membership exceeded 25 percent of the bargaining unit. These rights include access to members within Boland Bank's branch system during working hours.

Charles Wells, the regional secretary for Sasbo, said the

agreement essentially gave members an option not to work the extended hours. "Some staff could not work these additional hours."

He was heartened by the granting of organisational rights. "We are a very young union at Boland Bank, so this is a very positive development in labour relations. We are aiming at a 50 percent membership this year so we can get involved in salary negotiations."

(54) CT 16/11/97

100 retrenchments after

Protea Assurance takeover

Landmark building may be sold this year

LEWELLYN JONES
BUSINESS REPORTER

Greenmarket Square is echoing from the sounds of a massive shake-up in the landmark Protea Assurance Building. More than 100 staff members have been retrenched and the building is likely to be put up for sale this year.

This follows the R1-billion takeover of Protea Assurance by Mutual & Federal in October, and the subsequent sale of Protea's life assurance business to Commercial Union Life for R252 million. Mutual & Federal has held on to Protea's short-term insurance business.

Mutual & Federal managing director Ken Sagers told Cape Argus Business yesterday that as Mutual & Federal's head office was in Johannesburg, this had "regrettably" led to the retrenchment of about 100 of the 130 Protea head office staff.

Mr Sagers expected the remaining 30 employees would be retrenched this year when Protea's systems were transferred to Johannesburg.

The Protea head office staff had received "generous" redundancy packages, he said.

"However, none of the 60 or so Cape Town operational staff have been retrenched and they are in the throes of being absorbed into the Mutual & Federal structures."

Most will not have to move too far and will relocate to the Mutual & Federal offices in the Cartwrights Corner building a block-and-a-half away.

Protea Assurance managing director Andrew Tainton will go on pension at the end of next month, while most of the other executive staff members have decided to "move on".

"We moved very quickly to inte-

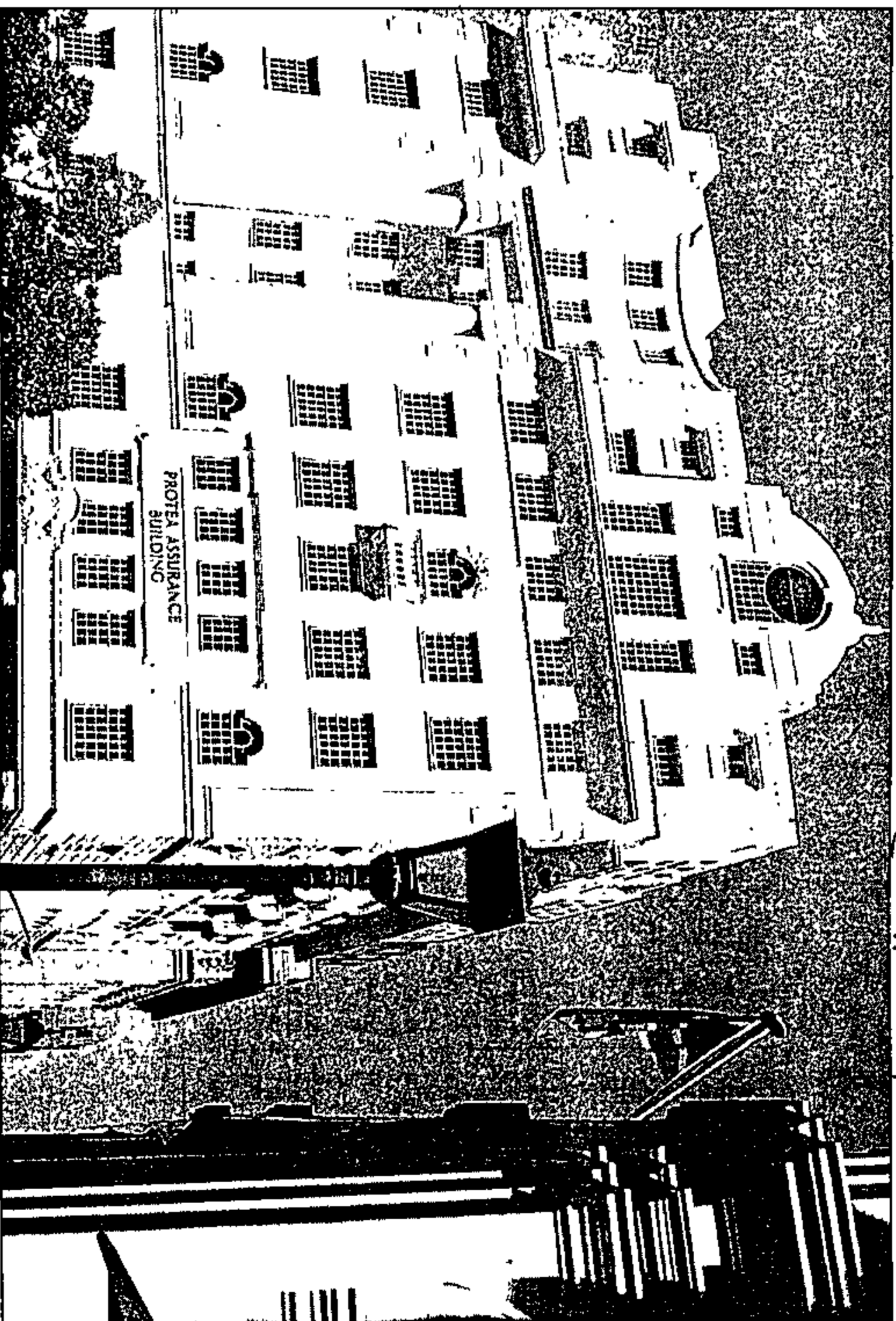

End of an era: the Protea Assurance Building on Greenmarket Square is being vacated following the takeover of Protea Assurance's businesses by Mutual & Federal and Commercial Union

grate the two operations throughout the country and aim to complete the process by the end of February.

The picture at Protea's life business does not appear as drastic.

Roger Wanless, the managing director of Commercial Union, said the sales and marketing operations of Commercial Union and Protea Life were being integrated.

While there were no immediate

retrenchments, Mr Wanless expected some to occur.

The merger of the two investment management operations as Commercial Union Investment Management

under Protea's investment supremo Duncan Carmichael has mostly been completed, with most of the Commercial Union investment team moving to Cape Town from Johannesburg.

Commercial Union Life and Protea

Life will, however, maintain separate corporate identities because of differences in their operating licences -

Commercial Union shareholders are limited to taking 10 percent of the company's profits as dividends, while Protea Life has no such limitation.

Mr Wanless said Protea Life and Commercial Union Investment Management would leave the building as other premises became available.

(59) AKT 23/11/94

JM McLAGAN

Black empowerment critics slammed

RAU 5/3/97

(59)

Metlife has most blacks in middle management - Motlana

BUSINESS REPORTER

Metropolitan Life chairman Nthato Motlana yesterday hit back at criticism that he and other blacks in high profile positions had not done enough for advancing black empowerment.

Speaking at Metropolitan Life's (Metlife) annual meeting, Dr Motlana pointed out that 38 percent of Metlife's mid-

dle management was black - substantially higher than any other company in the South African financial services sector.

In addition to this, he said, 20 percent of Metlife's senior management and 57 percent of supervisory management was black.

"It is not only the highly visible positions where we are seeking black inclusions, but at every level of decision-making in our business," Dr Motlana said.

Metlife had also been the financier of three black businesses within the National Empowerment Consortium, which acquired Anglo American's 35 percent stake in Johannesburg last October.

Dr Motlana sharply criticised the country's efforts in curtailing AIDS.

"I will tell you quite openly that I am appalled by the paucity of this country's effort in countering AIDS. I am referring not only to Government, but also to our

NGOs and the private sector. Neither sufficient money nor attention is being given to the problem."

He also criticised the proposed legislation to prohibit the pre-employment test for HIV infection.

"My quarrel is that the proposed Act is rather short-sighted in its thinking. Such legislation will only entrench the stigmatisation of AIDS."

He said HIV-infected persons were

already sufficiently protected by the Labour Relations Act which specified that employers may not unfairly discriminate against job applicants with disabilities.

"It is clear that most HIV-infected persons can remain healthy for a significant period of time and cannot, therefore, be prohibited from working."

Dr Motlana was, however, not opposed to pre-benefit medical testing for staff benefits, such as group life insurance.



Dr Motlana: appalled by efforts to fight AIDS

Wharton-Hood quits after LOA dispute

Belinda Beresford

LIBERTY Life vice-chairman Dorian Wharton-Hood resigned as chairman of the Life Offices Association on Friday after his company refused to accept an LOA-instigated investigation by the Financial Services Board (FSB) into its payments to brokers.

Wharton-Hood had argued against continued support for regulation of commission paid on life assurance policies but not competing products. He was elected the association's chairman last November.

LOA acting chairman and Norwich Life CE Charles Davies said the resignation followed "an internal disagreement about interpretation of an aspect of law relating to commission payments ... and also about adherence to the association's code of conduct".

Wharton-Hood said it was "ridiculous" that life assurance commissions were regulated by law while payments

to brokers for competing products such as unit trusts were not.

He said "so far" he was the only member of the LOA management committee to hold this view. He felt it was "shortsighted and ignorant of the real world" for the LOA to ignore the issue.

"We should either apply for commission regulation to apply to all competitors, or deregulate commission", he said. Deregulation would mean some form of commission disclosure.

Wharton-Hood said Liberty Life was not going to change its commission system as a result of the FSB's investigation. Although Liberty was prepared to go before an independent judicial authority to settle the dispute, it would not be judged "by people with vested interests" in the matter, he said.

Liberty pays brokers an administration fee for inputting life assurance applications onto a computer network.

LOA director Jurie Wessels said many members felt Liberty's adminis-

(59)
tration fees were actually commission payments. By law, commissions paid to agents and brokers have a maximum limit of 85% of the first year's premium. The administration fee pushed the commission to Liberty's agents over the legal limit, Wessels said.

Wharton-Hood said Liberty "highly disputed" the allegation the processing fees were extra commission. He added that other life assurers were being a "little bit backward" about the issue.

Although his resignation involved "no acrimony at this stage", a lot depended on which other LOA members would go along with his views, Wharton-Hood said.

On Friday the LOA agreed to implement a 21-day cooling off period for all new life assurance policies, effective from June 1. In addition, from the same date, all brokers and agents would have to disclose who they were employed by, and any ties with specific life assurers.

Life Offices Association could collapse over dispute

MARC HASENRUSS & MATI GETZ

Cape Town — The Life Offices Association (LOA), the representative body for South Africa's insurance industry, could be under threat if Liberty Life refuses to back down in a dispute over brokers' commissions.

The matter revolves around Liberty's decision to award payments to brokers using its new Blue Print system. The Financial Services Board has construed the

payments as a transgression of the Insurance Act.

Liberty, on the other hand, denied that the payments were additional commissions.

An industry source said the matter would be on the agenda when the association meets on Friday to discuss the regulation of commissions in the industry.

Unlike other financial services, commissions which are paid to insurance brokers are still regulated by law.

When asked whether Liberty could be forced to leave the association if it refused to yield on the Blue Print payments matter, the industry source said that was not impossible.

"It depends entirely on how Liberty behave ... but the LOA will try and find a way to persuade them to stay on board."

He warned, however, that if Liberty did leave the association there would be pressure on other companies also to break rank.

"If this happens then the whole association could effectively collapse," he said.

The LOA's internal disagreement over the Blue Print payments prompted Dorian Wharton-Hood, the deputy chairman of Liberty Life, to resign as chairman of the association last week.

Charles Davies, the association's acting chairman, said Wharton-Hood stood down in the interests of facilitating an open and constructive debate.

Wharton-Hood said last week that with Blue Print every broker had a laptop and could tap into Liberty's mainframe.

"They do the administration themselves. It is genuine outsourcing and we recompense them for that. This has irritated our competitors, who say we're paying more commission," he said.

Wharton-Hood denied that the payment was an additional commission. He emphasised that Liberty would be happy to be

judged by a competent independent court, but did not want to be judged by its competitors.

He also argued that all financial products, or no financial products, should be regulated.

"I'm on my own, (although) I'm not recommending deregulation. Other members say let's keep the regulation just for life insurance and that there's no chance of extending it. I fundamentally disagree and certainly won't change my stance," he said.

(59)

CF (BR) 10/9/97

Life Offices Association won't collapse - director

Break-up fears after Liberty dispute

LLEWELLYN JONES
BUSINESS REPORTER

The powerful Life Offices Association, which represents the multi-billion life assurance industry, is not under threat of collapse because of a dispute with Liberty Life, says executive director Jurie Wessels.

"I honestly don't think there is a chance of the Life Offices Association (LOA) breaking up," Mr Wessels told the Cape Argus.

The LOA is the self-regulatory body of the life insurance industry. It is also the representative body of the industry in its dealings with the Government.

Mr Wessels said if it disappeared Government would have to step in with "a lot of legislation" to take the place of the self-regulation or the man in the street would be in a very vulnerable position.

The association was a very useful instrument for its members to try and

influence their operating environment, but Mr Wessels conceded that the circumstances surrounding the dispute with Liberty could force the LOA to change some aspects of its code of conduct.

The battle with Liberty revolves around its decision to award payments to brokers using its new Blue Print system. The Financial Services Board has construed the payments as a transgression of the Insurance Act in that brokers' commissions would then exceed the maximum commission provided for in the Act.

"In this particular case, Liberty is doing something which is not specifically addressed in the law and there is a difference of interpretation," Mr Wessels said.

"Some members say what Liberty is doing definitely a contravention of the law, and Liberty disagrees."

Liberty, however, has said that the Blue Print system allows brokers to do the administration themselves, and they are simply being paid for that.

(59) ARG 12/3/97
But Mr Wessels said the fundamental question was not really how to deal with Liberty, but rather about having commissions regulated in law.

"We are the only industry that has commissions regulated by law - it's a good consumer protection measure - but it does put us at a competitive disadvantage," he said.

"For instance, the mutual fund industry (unit trusts) can pay higher commissions than we can for competing investments - that is really what is behind the dispute."

Mr Wessels said the industry would now have to take a fundamental view on whether or not commissions should continue to be regulated in law.

"It may happen that the LOA will have to concede that there are certain things which are so competitive in nature that the association does not have the power to regulate them ... and pass the ball back to the Government to clarify the law or make new law. The LOA's role would be diminished, but it certainly won't break up."

ASSURANCE *Deregulation proposed*

Task team to review commission payments

CT (BR) 17/3/97
MARC HASENFUSS

(58)

CAPE EDITOR

Cape Town - While there was no quick solution to the dispute between Liberty Life and the Life Offices Association over payments to brokers, the matter appears to have spurred progress on the possible deregulation of commissions.

Jurie Wessels, the executive director of the LOA, said at the weekend that discussions about the dispute between Liberty Life and other members of the LOA were continuing.

The dispute revolves around Liberty's payments to independent brokers using its new Blue Print system.

Liberty contends the payment is for an outsourcing of certain policy administration functions, but the LOA views the payment as an additional commission. Charles Davies, the new chairman of the LOA, said after the meeting that it could be weeks before the matter was concluded.

"These are weighty issues

which require thorough consideration to avoid short-term solutions," he said.



Jurie Wessels

Wessels disclosed, however, that the LOA had decided at Friday's meeting to appoint a task team — made up of representatives from various Life industry disciplines — to investigate the regulated commission structure as stipulated in the Insurance Act.

He said these representatives (who were still to be appointed) would report back to the LOA's management committee on the implications of abolishing, altering or retaining deregulation.

Commissions regulation is seen as an important consumer protection mechanism, although it does place life insurers at an disadvantage with other providers of investment products.

Gauteng facing job cuts as manufacturers head for coast

Ingrid Salgado

GAUTENG would face job losses in the short term as heavy manufacturing operations, the province's traditional industrial base, moved to the coast, Gauteng finance and economic affairs MEC Jabu Moleketi said yesterday.

However, this would largely be countered by provincial government plans to retain and attract other industries with high growth potential. Gauteng would outline its industrial development strategy in a document due for release at the end of May, Moleketi said.

Gauteng's economy contributes the lion's share of gross domestic product — 37,7% — followed by KwaZulu-Natal with about 15%. Moleketi expected the province to continue contributing more to national government's coffers than other provinces as its efforts to attract high growth industries kicked in.

Those targeted were the service industry, including financial, management and legal sectors, "smart" industry such as electronics, information technology, biotechnology and food processing sectors and business tourism. Moleketi cited Iscor — which was building

a new plant in Saldbanba Bay — and plans to site aluminium plants in Maputo as examples of business opting for coastal sites.

SA Chamber of Business economist Bill Lacey said high rail and road costs made moving a sensible option for the export-orientated heavy manufacturing industry.

However, sectors like electronics remained well placed to export from Gauteng through Johannesburg International Airport.

It was possible that food processing facilities would follow heavy industry.

Moleketi reaffirmed the provincial government's decision not to halt business's move to coastal areas, saying "narrow provincial attitudes" should not block natural structural changes to the economy.

An end to the sanctions era — and hence production solely for the domestic market — meant heavy industrial operations with an export bias had to be globally competitive. In this context, relocation was wise.

The trend would not affect the provincial government's revenue base. However, it could knock local government finances in the short term.

ND 27/9/94



Namakwa Sands MD Neville Keys announcing yesterday that the company would proceed with its second phase of development. Picture: GARTH LUMLEY

Union threatens bank in retrenchments

Patrick Wadula

THE SA Commercial Catering and Allied Workers' Union (Saccawu) is threatening to take African Bank to the Commission for Consultation, Mediation and Arbitration if the bank goes ahead with further retrenchments.

Saccawu finance sector co-ordinator Joseph Mosi said yesterday discussions with the bank on retrenchments were deadlocked, and the union was considering an

appeal to the commission.

"If we fail to resolve the matter at that level, the union will take industrial action against the bank," he said.

Mosi said the union and bank management had agreed to put further retrenchments on hold for at least six weeks while negotiations continued. Sources said bank staff were

concerned about losing their jobs

as plans to retrench 155 employees at the head office were being implemented. Mosi said the bank and the union had agreed to retrench staff at management level.

The bank planned to close 10 branches nationally, but it was not known how many employees might be affected. Management had also pro-

posed a wage freeze while talks were taking place, but this had been rejected by the union.

African Bank spokesman Jabu Magagula rejected Mosi's claim that the talks had deadlocked. A subcommittee comprising union and management representatives was expected to report back on its discussions next month, he said.

African Bank has been talking

to Saccawu regarding the proposed restructuring of the bank.

The first phase of the restructuring, already completed, was to implement controls and procedures, and to ensure they had been "satisfactorily" managed by staff since the bank was bought by NBS and New Africa Investments Ltd at the end of 1995.

The new shareholders of the bank were now also working with the union on a growth strategy, Magagula said.

59D BW 27/3/94

Shortage means higher salaries

(59) Sowetan 11/4/97

By Abdul Milazi

FINANCE professionals have become expensive to employ because they are in short supply, a factor which has pushed up salary increases in the finance sector by between 10 and 20 percent.

This was revealed by auditors Deloitte and Touche in their financial salary and market review published this month.

The review cited the brain drain among the newly qualified as well as the still small number of black chartered accountants entering the market as the reasons for higher salaries.

Employers in the finance sector, especially banking institutions, are

now offering incentives to their employees and, according to the survey, are even offering "golden hellos" to attract top level staff.

The total number of qualified black chartered accountants increases by 29 percent last year, and currently stands at 124. Deloitte and Touche argue that the competition to attract these newly qualified accountants is intense.

Many organisations have set up specific training strategies to help address the problem, although a lack of quality education offered at traditional black universities is of concern.

The review argues that pressure from trade unions is mounting for full disclosure of executives' salaries.

Banking sector bucks trend as number of jobs rises

Greta Steyn

THE number of jobs in the banking industry increased 1,9% last year—in sharp contrast to the declines recorded in many other sectors of the private economy.

Central Statistical Service (CSS) figures released yesterday showed also that employment in the insurance sector increased. Last year's jobs growth in the financial services sector followed a decade of expansion in the face of economic hardships which drove

other firms to cut jobs.

Financial services is the only sector—other than the public sector—which showed jobs growth between 1985 and 1995. Economists said financial services was not labour intensive and the sector would not provide solutions to SA's employment problems.

The employment growth in financial services contrasted with CSS data released last week for manufacturing, construction and mining. The construction industry had a particularly bad year, with

the number of jobs falling more than 7%. The decline occurred despite hopes that the reconstruction and development programme would gain enough momentum to improve the situation.

The manufacturing industry, the country's largest employer, also had a bad year, with employment shrinking more than 3%. The sector employed almost 1,43-million people at the end of December last year. Employment in mining and quarrying also fell. Employment in the public sec-

tor for the last quarter of last year is not yet available. CSS will publish a summary after employment data for all sectors is released.

Bureau for Economic Research economist Pieter Laubscher said the view that the CSS figures understated total employment in the economy was gaining ground. That meant the jobs situation might not be quite as bad as the figures suggested.

However, the bureau's surveys among business people broadly confirmed the official figures.

"The employment surveys in the first quarter of this year were still negative, but we can look forward to an improvement in the second half. At least the rate at which employment is shrinking has started slowing down," he said.

The bureau believed there could even be a small rise in private sector employment for the year as a whole—but the forecast was based on a bullish gross domestic product projection of about 3% growth this year. Laubscher said when growth in

fixed investment spending entered a new upward cycle, the effects on employment could be more positive than during the most recent upswing.

Fixed investment spending that was motivated by capacity constraints rather than the need to replace obsolete plant and equipment was likely to generate more jobs.

He also believed that the depressing effects on employment of increased global competition would begin to wear off.

Rises

Bank staff to join protest marches against robberies

Business Day Reporter

GOVERNMENT and the banking industry would liaise on bank robberies through a special committee that has been set up, Council of South African Banks CE Bob Tucker said yesterday.

After a meeting between members of Cosab's board and executive, safety and security ministry officials and the police, Tucker said bank staff would join protests against bank robberies.

Major banks would allow their staff to join the protest, planned for Thursday, organised by the South African Society of Bank Officials (Sasbo), and branches would be closed in areas where the protests were due to take place.

Reporter reports that Sasbo spokesman Ben Venter said: "We expect 50 000 to participate in protest marches."

Tucker said there was a high level of commitment on the part of the police and the ministry to addressing the bank robbery crisis.

Nine suspects were arrested at the weekend and rapid response units and a central investigation

function had been established. Police believed they were making progress in identifying four syndicates involved in bank robberies.

Tucker said banking representatives agreed police initiatives were in the right direction, but were anxious that real substance was given to those initiatives.

The following issues were identified for urgent consideration:

- The identification and recruitment of foreign experts in the areas of rapid response, investigation of bank robberies, and investigation of crime syndicates;
- That significant rewards be provided as an inducement to people with information for taking the risk of providing it;
- Resourcing the special units as it was clear that the units did not have all the necessary resources to be fully effective; and
- Close liaison in relation to statistics and communication.

He said the justice and correctional services ministries had to be involved in the campaign to ensure that criminals were not only caught but that they were successfully prosecuted and jailed.

Govt denies vendetta against newspaper

Reneé Grawitzky

SWAZILAND's government denied claims yesterday that it intended closing down the country's only independent newspaper, The Times of Swaziland.

This came in the wake of calls from a number senate members last week for the government to close the publication.

However, the government has apparently ordered most government departments and parastatals — such as posts and telecommunications, and electricity — not to advertise in the newspaper.

Advertising from parastatals and government departments amounts to about 50% of the newspaper's advertising revenue.

The Times' news editor, Vusi Gimindza, confirmed the verbal order yesterday and said the paper had already had cancellations from some departments.

The order to government departments and parastatals was in retaliation for an article The Times published last week about King Mswati, Gimindza said.

According to the article, the king had failed to pay rates on a property he owned.

Housing scheme 'will help local government'

Deborah Fine

THE housing ministry's programme whereby ownership of state-financed residential properties was transferred to tenants under a discount benefit scheme should help to alleviate local government's financial woes within the next three to five years, SA MD of international rating agency IBCA Mike Berry said yesterday.

IBCA SA has recently begun evaluating investment risks associated with SA local authorities.

Berry said research indicated local government was facing significant constraints due to the slow payment or nonpayment of municipal taxes and service fees.

Under the programme, the granting of freehold titles to residents would mean that rental payments would be converted to property tax payments.

Transfers of ownership did not take place until residents had signed undertakings whereby they agreed to pay off immediately in full any outstanding services arrears, or entered into agreements whereby they would pay off their arrears over a period.

Figures recently released by the housing ministry indicate that more than 1-million beneficiaries qualified for assistance under the scheme. Since the programme's inception in 1992, 96 257 residents had received assistance and had, if necessary, undertaken

to make good on arrears payments.

Berry said while the transfers represented a financial burden to the state — subsidies of R7 500 were granted to each qualifying household to acquire ownership — it was not unreasonable to expect the beneficiaries to "pay their way" in future.

Ownership transfers would also enable local authorities to take firm legal action against payments defaulters.

"The cash-flow difficulties faced by local government at present have the capacity to be turned around. While we anticipate that over time many of today's problems will be resolved, the sensitive nature of these issues, compounded by populist policies where hard decisions are required, is likely to delay the process," Berry said.

A Gauteng housing department spokesman said yesterday more than 150 000 potential beneficiaries had been identified in the province, of whom at least 18 000 were in Soweto.

Confirming that the programme's progress was slow but steady, he said that one of several problems delaying the swifter implementation of transfers was a resistance on the part of some identified beneficiaries to acknowledge their arrears.

However, national and provincial governments were examining ways to alleviate the problem through education programmes as well as other measures.

Charles Schwennes

PEANUTS

By Charles Schulz

Countrywide marches by bank workers against crime

Star 23/5/97

(S9) (S9) (S9)

Union appeals to Mandela to bring about 'another miracle' and make elimination of crime a priority

By Melaane-Avan Frens

Thousands of bank workers, who constantly face the danger of armed robberies at work, took to the streets yesterday to protest against violent crimes.

Banks in all the major cities joined a national call by Sasbo (South African Society of Bank Officials) to close down for two hours during the peak lunch hour trading period, to protest against bank heists and other violent crime.

But, Gauteng MEC for

Employees working with crime syndicates

safety and security, Jessie Duarte, pointed a finger back at bank employees, questioning their competence.

Addressing protesting bank workers who had gathered at the Library Gardens in Johannesburg's CBD during lunch-time yesterday, Duarte said

every (security) video seen of a robbery showed weaknesses in bank security.

While the Government had implemented measures to deal with crime, bank robberies were escalating because bank employees were working with syndicates.

Every cash in transit robbery over the past three weeks had been pulled off with inside information, she said.

"Someone is telling their friends on the outside when to rob you. How are you going to help?"

"You allow criminals amongst yourselves. You allow robbers to open accounts with the money that they stole from you," she said.

While the Government had a commitment of assistance by bank managers, it was up to the rest of the banking staff to be alert, specially to the possibility of colleagues working with crime syndicates, Duarte said.

Sasbo, which was joined by Cosatu and Popcorn, warned that yesterday's action was only the start of much wider protest action.



Together against crime ... bank employees gather at Johannesburg's Library Gardens yesterday to draw attention to the dangers they face in the workplace.

The union is attempting to involve all businesses in a similar protest in the future.

People are saying the new SA is corrupt

Graeme Rowan, general secretary of Sasbo said.

Addressing the hundreds of bank employees and supporters at the Johannesburg Library Gardens Rowan said: "You (Mandela) are achieving miracles with the new South Africa, but another miracle is

desperately needed. Please make the elimination of crime your top priority.

"Give it the Madiba magic that has brought our country so many other honours.

"People are saying that the new South Africa is corrupt, they say that the police, who are supposed to be protecting us, are the real criminals.

"That is a blight on your administration, sir. That is a blight that must be eliminated."

Yesterday's protest has received political support from both the ANC and the National Party, who said this was a desperate effort to show that crime was getting out of hand.

They don't know if they will be alive at the end of the working day

By Melaane-Avan Frens

Hennie Bezuidenhout's bank has been robbed three times in the past five weeks.

"They come in waving their guns and shout at people to lie on the ground. They jump over the counters and intimidate the tellers to give them money. Then they start pulling open the drawers, helping themselves to money.

"It is all over in two minutes,

but those two minutes change your life for ever," said Bezuidenhout, who is the manager of Rosebank's Trustbank.

All the tellers at the bank are female. One of them has been hospitalised, not because of physical injuries, but due to psychological injuries as a result of the trauma.

Another has been transferred and two more have applied to be transferred at the end of the month. People who applied for jobs at the bank have decided against working there and last week only 60% of the staff arrived for work.

"We have reached a stage where we don't know if we will be alive at the end of the day," he said. Yesterday's mass protest by bank employees gave him the opportunity to talk about his experiences: "It was good to know that there are others out there who have been through the same thing."

Staff close banks in crime protest

14 killed in 180 robberies

ARG 23/5/97 (59)

THABO MABASO
BUSINESS REPORTER

Banking came to a virtual standstill during lunch hour yesterday when staff took to the streets to protest against the increase in bank robberies.

In Cape Town nearly 1 000 bank employees marched from the Grand Parade to Parliament where they handed a memorandum calling for action to a Ministry of Safety and Security official.

They called on the Government to apply stricter bail conditions for serious crimes and proposed better pay and conditions of employment for the demoralised police service.

South African Society of Bank Officials held similar marches in other major centres.

Society secretary-general Graeme Rowan said the aim of the protest was to urge the Government to pull up its socks in dealing with violent crime.

"Gangsters must be removed from society. Bank workers are sick and tired of being victims."

Mr Rowan said there had been about 180

bank robberies since January, most of them in Gauteng.

More than R30-million had been stolen and 14 bank employees killed.

"The South African finance industry is the country's shop window to the world and if the workers in it are not safe, investments are also not safe, tourism will suffer and Cape Town will not get the 2004 Olympics," Mr Rowan said.

Banks whose staff took part in the march closed for business between noon and 2 pm.

The protest had the blessing of the Council of South African Banks which represents the country's major banks. The council published a full-page advertisement with black and white photographs of a bank robbery in a morning newspaper, applauding the action by employees.

"After all our staff have been through in the past few months, we're sure you wouldn't begrudge them two hours to protest," the advertisement said.

It added that the banking industry supported the society's appeal for more effective measures to protect the safety of bank staff and customers.

LOA to try to resolve Liberty Life dispute

Belinda Beresford (59)

BD 30/5/97

THE Life Offices Association (LOA) will try today to resolve an internal dispute over commission payments which could otherwise lead to the destruction of the organisation.

Liberty Life has been in dispute with other LOA members over a R125 fee it pays brokers for using the Blueprint system. The LOA has said the payments are commission and

Liberty is in breach of regulatory guidelines.

Liberty has said the payments are a service fee, paid regardless of whether a sale is made. Liberty directors have said repeatedly the company will leave the LOA rather than back down.

Liberty Life executive director Steve Handler said yesterday that if necessary Liberty would resign under "conditions of great regret, but

adhering to principles". He said no compromise deal had been suggested, but Liberty regarded the dispute as a "question of principle".

It was the intention to resolve the situation today.

Observers of the dispute say Liberty's departure could signal the end of the LOA, which one analyst described as one of the most powerful financial services lobbying groups.

Black bankers' US training pays off

David McKay

A PLAN to train black SA bankers, initiated six years ago by several major US banks, is producing results, according to a report recently presented to President Nelson Mandela.

The banks, which include Chase Manhattan and JP Morgan, said in the report that about 100 SA black businessmen had successfully passed through the Professional Development Programme (PDP).

The candidates, representing more than 20 companies, spent up to six months in the US, working in their respective fields in a series of cycles which spanned a six-year period. One of the writers of the report said

the candidates were among the exceptional young business men and women "who are poised to assume leadership roles in their respective companies and the society in general".

An alumni group had been formed and a broad mix of locally based projects in education, housing and business training were being explored.

"Many of the SA businesses that have participated have also agreed to consider proposals for support of specific projects," the report stated.

Many of the first candidates involved in the programme had been promoted to more senior and influential positions, underpinning the declared intentions of the programme. Subbranch supervisors had become

managers and general managers had been moved up to directorships following completion of the programme.

Successful graduates include Alan Mukoki and Tsoane Mphahlele. Mukoki, previously an account analyst at Standard Bank, is now head of Neden-terprises, a Nedcor division. Mphahlele, formerly a Southern Life branch manager, is now a senior executive at Worldwide African Investments.

The training programme involves an intense six-month work experience, a series of all-day academic sessions and informal seminars and activities that addresses topical issues.

In on-the-job training, managers from participating SA firms were placed with New York City sponsoring

firms. Mentors were identified at each of the firms to provide advice, counselling and support.

The educational programme concentrated on three subject areas - internal business, corporate strategy and management of large enterprises.

This was conducted within the broad framework of operating in a highly competitive and technologically changing environment, helping the candidates develop capabilities of critical thinking and systematic analysis.

To complement their training, and broaden their understanding of the banking environment, the participants were exposed to a wide range of views of contemporary issues during their stay in the US.

BD 5/16/97 (59)

(15)

BANKING SECTOR SHEDS JOBS FOR THE FIRST TIME IN SEVEN YEARS 69

Cape Town — The banking industry shed 1 721 jobs in the year to March 31, the Central Statistical Service said yesterday. This is the first drop in job numbers in the industry in more than seven years. Total employment in the sector dropped from 128 577 at March 31 last year to 127 986 at March 31 this year.

Senior bankers said the latest figures might signal the start of a new trend of declining employment in the industry. John Verster, the head of human resources at Standard Bank, said: "Competition from international banks is forcing local banks to cut costs. Staff cost is an area where savings are still possible. Foreign banks are also cutting staff numbers by outsourcing functions and forcing local banks to follow suit."

In March last year 63 percent of workers in the banking industry were white. The figure dropped to 58 percent by March this year, the service said. — Christo Volschenk

CP (BR) 117/97

IN BRIEF

Wildcat strike delays cash deliveries to major banks

DD 29/7/87
CASH deliveries to four major bank outlets in Gauteng, North West and Mpumalanga were delayed by up to five hours yesterday when about 60 SBV protection officers refused to work, the SA Society for Bank Officials said.

The officers, who man armoured cash delivery trucks for Absa, First National Bank, Standard Bank and Nedcor, were protesting against what they alleged were unacceptable safety conditions and an insensitive management.

Society spokesman Bakkies Preller said they resumed their duties after management agreed to meet the society today to resolve the problem.

SBV is jointly owned by the four banks.

Southern Life to shed jobs in restyling plan

CT (BR) 25/8/97

(59)

MARC HASENFUSS

Cape Town — Southern Life, the life assurance company, will shed about 900 jobs in the next two years in a transformation programme to reduce costs and improve investment performance.

Jan Calitz, the chief executive of Southern Life, said at the weekend the introduction of streamlined back office and processing operations because of integration would see administrative staff reduced by about 600 over the next two years.

A new market focus and the rationalisation of product and service offerings would also allow a reduction in sales staff by about 300 over two years, Calitz said.

A benefit of this integration and new focus would be a reduction in the company's cost-

to-income ratio from 17,7 percent at present to 13 percent by the end of the 2000 financial year.

He said retrenchment would be considered only as a last resort. "We experience natural attrition of around 11 percent (about 300 people) of our administrative staff each year, while the turnover rate of our sales staff is higher."

Calitz said this number would be complemented with reskilling and redeployment, voluntary early retirement and voluntary severance.

"This is a narrower market sector than our current focus, but one which shows strong growth and better matches Southern's capabilities."

He said the product range rationalisation would lead to a significant reduction in administrative complexity and costs.

By Shadrack Mashalaba

ANGRY South African Society of Bank Officials (Sasbo) members took to the street in Pretoria yesterday in protest against unilateral actions implemented by the Land Bank.

In a statement Sasbo said the protest action was a result of an uncarrying management hellbent on transforming the organisation with total disregard to the needs of its workers.

Sasbo and the management of the Land Bank were scheduled to have a meeting at the bank's premises in Pretoria yesterday. The meeting could not take place because the union asked for a postponement.

Land Bank spokesman Benedict

Sasbo members protest against bank's actions

Southern 25/11/97

Mosette said Sasbo asked that the meeting be postponed to Wednesday without giving any reason.

Mosette said the bank's management was surprised at the behaviour of union members when they staged a protest.

She said the whole move was a deliberate effort to derail transformation currently under way. "While the

process was under way, there was nothing in black and white to suggest that the move is unilateral".

The Land Bank was formed in 1921 to help farmers. Previously the bank used to help white commercial farmers but because of transformation it now also offers assistance to emerging black farmers.

Sasbo general secretary Graeme

Rowan said that the union was against management's autocratic and uncaring attitude and demanded that union leadership put a halt to the current process pending proper negotiation of the issues.

This includes a switch to English as the only means of internal communication, the unilateral curbing of leave entitlements and the apparently redundant

positions of senior managers as a result of restructuring.

Rowan said Sasbo also objected to Land Bank managing director Dr Dolny Helena, widow of the late Joe Slovo, who allegedly used words such as "tough shit" when dealing with employees who came to her with grievances.

Mosette said the board made a decision to change from Afrikaans to English. However, at present "clients are addressed in languages they feel comfortable with".

About the alleged usage of vulgar words by Helena, Mosette denied any knowledge of such incidents, saying "I am not aware where and when she made such comments".

FBC to cut staff by quarter

Belinda Beresford

(59) 00 19/11/97

FUTURE Bank Corporation (FBC) is to cut its retail banking staff by about 25% in a rationalisation process which will also see the closing of some branches.

FBC retail banking executive director Trevor Fourie said there would be a loss of about 90 positions, ranging across all levels from general management down. Another 40 to 50 people would be relocated or retrained.

Fourie said the changes were part of the integration process between Citizen's Bank, Bophuthatswana Building Society and Future Bank, which merged to form FBC earlier this year. The merger had involved the consolidation of three head offices and three businesses into one.

In line with modern banking trends FBC would be converting its "very manual-intensive" services into more electronic facilities.

From next week FBC would be creating a support system which would offer staff various forms of counselling, advice and support in a "very tough and trying time". The rationalisation process should be completed within a couple of months, he said.

Saccawu to get FNB protest report today

ET (BR) 26/11/97 (59)

FRANK NXUMALO

LABOUR CORRESPONDENT

Johannesburg — About 200 First National Bank (FNB) employees allied to the South African Commercial, Catering and Allied Workers' Union (Saccawu) will gather at the Library Gardens in central Johannesburg today to receive an FNB management report on their protest march last year.

Joe Musi, Saccawu's spokesman, said the FNB employees who had protested at the time against "unilateral deductions" on company benefits had been issued with individual written final warnings.

Musi said top of the agenda at the union's conference next week would be the massive retrenchments planned by the financial services sector and alleged discrimination in the workplace.

Meanwhile, the South African Institute of Race Relations will hold a media briefing today on unemployment in the

country. The institute said unemployment had become "one of the most serious and intractable" socio-economic problems.

The institute said official estimates of unemployment were 32,4 percent in 1994 and 29,3 percent in 1995.

"According to comparative estimates by the International Labour Organisation, only Macedonia and the island of Reunion had higher rates of unemployment than South Africa," the institute said.

"Other countries with notoriously high unemployment rates, such as Spain and Algeria, are well below the South African figures, with rates just above 20 percent."

However, the institute said a recent study by its team, led by sociologist Lawrence Schlemmer, found that "official estimates are too high".

A significant portion of people who claim to be unemployed were active in the informal sector, the study found

Official estimates of unemployment in South Africa are too high, study finds

BD 26/11/97

East London Land Bank staff protest against Dolny

~~(58)~~ (59)
EAST LONDON — All 30 staffers at the Land and Agricultural Bank of SA's East London branch picketed yesterday against the "radical changes" instituted by national MD Helena Dolny.

This followed nationwide protests on Monday.

The regional secretary of finance union Sasbo, Adrian Coetzee, said the staff were outraged by radical, unilateral changes introduced by Dolny since she joined the bank six months ago.

He said Dolny's unwillingness to negotiate the changes, which were part of the affirmative action process at the bank, could drive the mostly conservative employees of the bank to strike. This option would be discussed at a national Sasbo meeting with the bank's management today, he said.

Coetzee said the main grievances were that senior personnel had to reapply for their posts, but there was no indication what would happen if their applications were unsuccessful; and English would be the official language of the bank, although Coetzee said 70% of the bank's employees and clients were Afrikaans-speaking. — ECN.

Absa staff threaten strike action

BUSINESS EDITOR

(59)
ARLT 19/11/98
Employees at ABSA banks across the country are threatening to stop work next week now attempts to resolve a salary dispute have failed.

Piet Heymans, assistant general secretary of the 75 000-strong banking union, Sasbo, confirmed that the Commission for Conciliation, Mediation and Arbitration had failed to resolve the salary dispute last week.

The 22 000 Sasbo members in Absa were asking for a wage increase of 11%, to be implemented in April. Absa was offering 10,25%, he said.

"Our members are adamant that they want to share in the improved results of the Absa group. The decision to take industrial action was reached after serious consideration and as a last resort," Mr Heymans said.

Absa was paying 20% more in dividends to shareholders, and the

11% salary demand would cost the bank "a mere R10-million".

A programme of "rolling mass action" would probably begin on Tuesday next week and culminate in a general work stoppage the following Friday, Mr Heymans said.

"Our members are demanding that they be paid fairly for their hard work and extra effort.

"We trust that Absa clients will understand, and bear with the disruption that industrial action may cause."

CT(BR) 22/1/98

Absa strike likely to be averted

FRANK NXUMALO (59) (BR)

Johannesburg — The planned three-day strike at Absa, the banking group, could be averted as the South African Society of Bank Officers (Sasbo) said yesterday that Absa's revised offer was likely to be accepted.

The parties deadlocked last Friday at the Commission for Conciliation, Mediation and Arbitration (CCMA) when Sasbo rejected a company offer of a 10,25 percent wage hike, sticking to its demand of 11 percent.

Although Piet Heymans, Sasbo's assistant general secretary, would not be drawn into revealing the details of the revised offer because of the "sensitivity" of the issue, he said it was an offer "we could live with".

Meanwhile, Shaun Oelschig, a Sasbo spokesman, said hundreds of non-clerical staff at Standard Bank nationwide had been "invited to apply" for voluntary severance packages that could be worth about 10 months salary plus pension contributions.

John Verster, Standard Bank's general manager for human resources, said the bank had been "looking at ways of reducing staff and costs in areas of non-core activities and operations".

CT(BR) 22/1/98

Finance union Sasbo declares payout dispute

Reneé Grawitzky

TRANSFORMATION at the Land and Agricultural Bank of SA has run into a hitch, with finance union Sasbo declaring a dispute over the payment of retrenchment packages in the event of jobs becoming redundant.

In 1996 the then Land Bank's board adopted a retrenchment package several times larger than the industry norm. This meant individuals facing

retrenchment could land up with retrenchment packages running into millions of rands.

The new board appointed by the cabinet last year reviewed the packages in the light of financial industry norms and the potential cost to the taxpayer.

Bank spokesman Bernadette Mosele said restructuring had resulted in a number of major changes to the organisation's structure and its way of operating. The role of the head office had changed

dramatically with the subsequent decentralisation of functions to the 25 branches countrywide.

Within branches, functions had also changed in view of the shift in focus to servicing a broader market outside the traditional white farmer market.

Such changes could result in many jobs becoming redundant as job descriptions had changed and personnel would have to reapply for their jobs. In this context, the union alleged that

the bank had unilaterally changed the severance package, the subject of an agreement.

Sasbo spokesman Ben Venter said the bank claimed this change had been based on sound business principles.

He said that in the event of retrenchments, "under the old and new scenario, the difference would amount to millions of rands".

The previous formula was similar to the current structure in place in the pub-

(59) 20 26/3/98

Venter said the dispute was being referred to the Independent Mediation and Arbitration Services of SA.

Under apartheid, agricultural policy had revolved around co-operatives, low-cost loans and benefits which had originated from the various control boards in agriculture.

The bank's primary role within this structure was to provide subsidies and loans for low-cost white farming.

packages could land up with retrenchment packages running into millions of rands.

Absa sees few job losses

ED WEST
DEPUTY BUSINESS EDITOR

ARC 14/5/98

(59)

The merger of Absa Group's four bank brands will result in only a negligible number of retrenchments in the Western Cape, says regional general manager Pieter van der Merwe.

The group says the merger of Volkskas Bank, Allied Bank, United Bank and Trust Bank will lead to important savings, but will cost 1 900 jobs across the country over the next two years.

Mr Van der Merwe said Absa had 110 branches in the Western Cape which employed 3 200 people.

There had been a freeze on employment in the province and the staff turnover of 10% a year – a little lower than Absa's national average of 12% to 14% – ensured that staff would be reduced sufficiently through natural attrition.

A small number of jobs would be lost in the province, mainly through the rationalisation of branches.

Banking union rejects Cosatu levy for election campaign

By EDDIE JAYIYA

(59)
STW 17/8/98

The South African Society of Bank Officials (Sasbo) dealt Cosatu a political blow yesterday by rejecting a levy aimed at supporting the ANC's election campaign.

The rejection followed calls by the central committee for various unions to donate R1 per member to the federation so that it could help the ANC in its 1999 election campaign.

Sasbo finance general-secretary Graeme Rowan told The Star that his union, with a

70 000 membership, would not deduct the money from its members.

"Our constitution precludes us from supporting any political organisation," he said.

"Our members are drawn from different political organisations and we cannot therefore be seen to be aligning ourselves with any political party. We will not how-

ever stop individual members from donating to the fund."

Cosatu spokesperson Nwethu Mpati said the levy had been proposed by the central committee, made up of 500 delegates. "It is up to the membership to decide on whether the levy will be adopted," she said.

"At the moment, Cosatu has not received an official response from Sasbo regarding the levy. We will hear

from Sasbo and other unions this week."

Mpati said Sasbo members would have to take the decision about the levy and she hoped Sasbo leadership would allow its members to exercise their democratic right.

"We go to the executive committee meeting with an open mind, and our affiliates will be free to deliberate on the matter. The leadership will be guided by the delegates at the meeting and we hope to reach a decision that will satisfy everybody," she said.

“
**Up to
members
to decide**
”

NEWS

90% of branches to close in cost-cutting exercise aimed at lifting competitiveness

Stannic to retrench 40% of employees

MATT GETZ

MARKETS EDITOR

Johannesburg—Stannic, the installment finance division of Standard Bank, would retrench 40 percent of its employees and close down 90 percent of its branches in a bid to cut costs and make itself more competitive, Dave Brown, the managing director, said yesterday.

"In an increasingly competitive market, we have had to address our cost structure. Through the use of technology, we can generate the same returns we did before. Unfortunately, there will be

job losses and we don't need so much bricks and mortar.

"We have 46 branches. Traditionally, we processed finance and all other transactions at each branch. Now we will centralise (all the processing) in four centres (Johannesburg, Pretoria, Durban and Cape Town), which allows us to cut down on branches and achieve economies of scale."

"The new technology includes imaging, scanning and workflow, all of which will be handled from the four nodes, which will service outlying areas.

But Brown said it was impossible to

give numbers on how much the company was spending on the technology because of all the factors involved. There would also be a number of other charges for closures and write-downs in asset values.

Brown said 980 workers would be retrenched, "a small percentage (of whom) would be realistically redeployable (elsewhere in the Standard group)". Most of them, but by no means all, would be administrative workers. "With the current structure," he said, "lots of sales people have been burdened with administrative functions. In our East

Rand pilot (which has been running for two months) and by operating sales people remotely they have become more prominent and more effective ... There will be no reduction in sales and service. This is a productivity drive."

The process, which had been under way for a while, should be finished within six months, he said.

Though the company would have many fewer branches, salespeople would still be seen in remoter areas. "As part of the Standard group," he said, "we will continue offering our products through Standard bank branches."

ET (BPR) 15/9/98 (59)

Land Bank's restructuring gets stuck in the wage mire

Reneé Grawitzky

THE restructuring of the state owned Land Bank ran into further difficulty yesterday after a one-day wage strike by members of the traditionally conservative finance union, Sasbo.

The wage dispute coincided with staff resistance to the bank's restructuring plans, aimed at broadening its range of services and client base and becoming more cost effective.

Such plans could result in retrenchments, staff transfers and changes in job titles and tasks.

Industry and union sources said the bank's restructuring had taken on political overtones.

The wage dispute revolves around Sasbo's demand for a 10% increase, while the bank has offered 6,5%. Members of the SA Commercial, Catering and Allied Workers Union did not participate in yesterday's action.

Sasbo spokesman Ben Venter said the strike was about wages and not about the restructuring. He said the union's demand was in

line with settlements achieved with other major banks.

Venter said the staff learnt that the bank had budgeted for a 15% increase at the end of last year, but was now willing to offer only 6,5%.

Land Bank MD Helena Dolny said management wanted to restructure salaries to be market related and to introduce a performance-bonus scheme. This explained the 6,5% wage offer, a 2% increase in the housing allowance and a 5% performance bonus. This package would cost the bank R17m, while the union's demand would amount to R25m.

Dolny said there was a shortfall of R6m between the union's demand and funds available.

Management, she said, had a long-term view on restructuring and staff development, and had allocated R7m to training.

Sasbo said there were plans to meet the bank next week to try to resolve the dispute, which had already been referred to the Commission for Conciliation Mediation and Arbitration.

Sparks expected to fly over suspension of Sasbo affiliation

Reneé Grawitzky

THE suspension of Sasbo's affiliation to the Congress of SA Trade Unions (Cosatu) until after the 1999 general elections was expected to spark heated debate at the union's two-day national congress starting today, union sources said.

The election of Sasbo's office bearers, instead of their appointment, was also likely to be hotly debated as internal divisions emerged ahead of the start of the congress, they said.

Internal divisions came to the fore during Cosatu's central committee meeting in June, where the federation adopted a resolution that all affiliates contribute R1 per member to be used for activities linked to the general election.

The adoption of this resolution was used by Sasbo's Durban branch to call for the union's suspension from Cosatu until after the elections.

Sasbo's membership base is traditionally conservative. However, insiders claim that left-wing elements are growing in influence.

Two govt groups offer different maize export figures

Paul Vecchiatto

SA MAIZE export numbers continue to be clouded by uncertainty with two government mandated organisations offering widely differing numbers.

For the financial year from April to August, the Perishable Products Exports Control Board, which

has the responsibility to inspect shipments for export, has said that it has inspected 385 581 tons of maize, while the SA Grain Information Service has declared that 239 000 tons has been exported.

Grain information service maize information compiler Ferdi Jacobs said part of the discrepancy may be because not all maize earmarked for export had left the country yet.

The information service was formed out of the now-defunct maize board as a means of getting information about maize to the market. Its latest numbers go as far as August.

The Perishable Products Exports Control Board refuse to comment on their numbers as the organisation saw itself as an impartial inspectorate for export shipments.

Since January, the exports control board has inspected 739 599 tons of maize for export.

However, the industry operates on an annual cycle from May to April. The elevator operators, the companies which load maize on to ships at ports, say they have handled about 200 000 tons of maize since April.

Agriport said that it had loaded 160 000 tons of maize, of which 25 000 tons was white maize, and Durban Bulk Shipping had handled about 16 500 tons white and 18 000 tons yellow. — I Net-Bridge.

TODAY'S WEATHER

GAUTENG Johannesburg 12/15	MPUMALANGA Nelspruit 12/15	NORTHERN PROVINCE Pretoria 10/17
NORTHWEST Pretoria 10/17	FREE STATE Bloemfontein 06/21	KWAZULU-NATAL Durban 11/17

Strike threat at Nedcor

ARG 14/11/98
JEAN LEMAY

Employees of one of South Africa's major banking groups, Nedcor, have threatened to strike if the bank does not meet their unions' demands in pay negotiations.

Representatives of the SA Society of Bank Officials (Sasbo) and the Insurance and Banking Staff Association (Ibsa) confirmed that most members had voted yesterday to strike if the bank did not meet their demands.

However, Ashley Sutton-Pryce, the human resources director of Nedcor said the ballots were "testing the water" and that the bank had not put its final offer on the table. There was no question of industrial action. Negotiations would continue on Monday.

He said he was quite sure that the unions' final offer was not on the table. The unions had "jumped the gun".

The unions could not be reached for comment late yesterday.

The unions objected to the bank's offers being linked to a risk element: a 24% growth in the bank's earnings per Nedcor Group share and a 28% increase in profits after tax for 1998.

Sasbo told its members yesterday that its final demand was for an 11,5% increase for lower-grade employees, an increase of 10,5% on guaranteed pay for higher grades and a two-week productivity bonus.

The bank's final offer was 4,5% on lower grades and 3,5% for higher grades, said Sasbo. In addition, the bank was prepared to make a further 2,5% available in July 1999 on the risk element.

The 2,5% would be back-dated to January 1 1999, it said.

Ibsa said the bank had effectively split the increase due to its members. It said the bank had moved "the goal posts" by demanding that "future targets should be met".

Nedcor's attributable income rose 28% last year to R1.820-million. Earnings per share went up 24% and return on equity to 23,4%.

Nedcor signs wage deal with Sasbo, staff body

Reneé Grawitzky (79)

NEDCOR yesterday signed a 15-month wage agreement with Sasbo, the finance union and the Independent Banks' Staff Association amid some controversy surrounding a proposal that wage increases should be linked to company performance.

The agreement ensures that from next January, Nedcor employees will receive increases ranging from 8%-9%, depending on the job category,

plus an additional 0,5% linked to promotions.

A further 2,5% increase will be granted for the three-month period from January to March 2000. The minimum wage will be R2 000 a month.

Sasbo said the unions opted for this instead of two other proposals which linked a portion of the wage increase to company performance. The unions were opposed to this "risk element" and subsequently bal-

loted their members last week.

The unions believed this option was unfair as staff had no control over earnings a share or net profit after tax. In addition, it was the first time the company had introduced such a proposal into salary negotiations and had not raised its new approach in pre-negotiations meetings.

Sasbo's chief negotiator Carmen Harty said the union might have considered this option if the "conditions for risk had been more positive".

BD 20/11/98

African Bank will shed 200 jobs

(59) ARG (BR) 21/11/98

FRANK NXUMALO

LABOUR EDITOR

Johannesburg — Close to 200 African Bank and Alternative Finance employees faced retrenchment by the middle of next month as the bank refocused its operations following the merger of the two institutions and the acquisition of African Bank by the Theta group, Sonya Fourie, a bank spokesman, said yesterday.

African Bank is restructuring to concentrate on the micro-lending sector.

Employees would be retrenched on a last in first out basis and given a severance package calculated on the statutory minimum of one week's salary for every year of completed service.

However, negotiations were

under way to accommodate the views of both the South African Commercial, Catering and Allied Workers' Union (Saccawu) and representatives of non-unionised employees.

"Alternatives to be considered before proposing forced retrenchment of staff include calling for volunteers, considering alternative positions within the group, looking at ways to achieve the required structure without job losses and possible outside placement of staff," the bank said in a notice of termination of employment.

All non-core facilities and products will be contracted out.

Fourie said although big banks had up to now been reluctant to move into the micro-lending sector because of perceived high risks, they were starting to

look more closely at this market.

The bank said its vision was to be the market leader in the provision of "select financial services to the under-banked market".

A number of strategies would be implemented to refocus the bank from "a small, unprofitable institution offering traditional financial products in a highly competitive environment into a profitable, medium-sized niche institution offering tested non-traditional savings and loan products ... I think we will be in a position to do it profitably," she said.

Strategies under consideration include restructuring the bank's balance sheet by ring-fencing its assets and expanding its deposit base to create sufficient funding capacity.

FINANCE - LABOUR

1999

Liberty awaits judgment on retrenchment dispute

RONNIE MORRIS

Cape Town — Liberty Life, the insurance titan, will know in February whether the Labour Court will order it to reinstate 23 employees who were retrenched when two divisions closed after automation.

The employees, all with six or more years' service, want the court to find that their retrenchments on June 3 1996 were not only unfair labour practice but invalid.

The court was told their woes started when Liberty Life decided to automate the functions in the New Business department and Marketing Technology Support Services (MTS) in Cape Town and Durban.

When automation was first explained to staff assurances were given that Liberty Life did not retrench.

Towards the end of September 1995 the Individual Business division made a decision to close MTS and New Business.

Present were Yves D'Halluin, a managing director, Gavin Came, general manager of marketing, Gill Bogie, divisional manager of New Business, James Skuse, human resources manager, and Hershel Meyers, general manager.

A month later the decision was conveyed to a Liberty Life Management Committee (Mancom) meeting, attended by executive directors of the various divisions.

There D'Halluin explained that about 300 jobs would become redundant during 1996.

It was noted that 65 percent of the jobs affected were occupied by "non-whites", and the fear was expressed that an announcement of their intentions might provoke "industrial action and possibly a strike".

When the court case started in April 1997 the applicants requested copies of the minutes of Mancom and board meetings for the period October 1 1995 to May 31 1996.

Liberty Life refused to comply and was subsequently ordered by the court to hand over the minutes. It refused and appealed against the order to the Labour Appeal Court, and thereafter brought review proceedings.

Eventually the applicants' lawyers inspected the relevant minutes and used them in the cross-examination of Andre Vermaak, the group human resources manager and Liberty Life's main witness.

Colin Kahanowitz, counsel for the applicants, told the court that Liberty Life had failed to call every single important witness who should have been called to testify on who made the decision to close the departments and why.

"The respondent's statement of defence proved to be an extremely malleable document. Some aspect of its defence was always changing as the insurance giant's trial progressed.

"True to its belief in the power of innovation, it regularly sought to discard old versions of the facts and innovate by introducing new versions," Kahanowitz said.

The employees' woes started when Liberty Life embarked on plans for automation

CT (BR) 15/1/99

(59)

Saccawu lays charges against life bosses

By ALIMPHAKI

(59)

CP 31/1/99

THE South African Commercial and Catering Workers' Union (Saccawu) has laid a charge of fraud against two of South Africa's business heavyweights, Donald Gordon and Roy Andersen.

The charges were brought at the Hillbrow police station on January 8 this year after protracted negotiations with Liberty Life over the retrenchment in 1996 of about 350 security personnel.

Gordon is the founding chairman of Liberty and Andersen its chief executive officer.

In an affidavit Saccawu alleges that the charges against Gordon and Andersen are based on numerous acts of misappropriation and self-enrichment at the expense of ex-employees.

Saccawu alleges that Liberty in writing and verbally made "fraudulent promises for alternative employment to its ex-employees". To date no such employment was given and the ex-employees are struggling to make ends meet, with some already having their houses attached, claims Saccawu.

Another allegation is that Gordon and Andersen have offset the pension/provident funds of the retrenched workers against the balance owing to Liberty Life on their housing bonds.

The affidavit further mentions that Gordon and Andersen have taken unfair advantage of their ex-employees, most of whom are illiterate and ignorant of their rights.

It is further alleged that Gordon and Andersen knew full well that their ex-employees cannot afford justice and

have been severely prejudiced due to lengthy and costly litigation and abuse.

The matter involving the former security personnel has been dragging on for some time now.

Their last day of service at Liberty was August 31, 1996, where they were promised, according to a memo in City Press's possession, that among others, all their severance benefits in terms of the recognition agreement will be paid.

The ex-employees were further promised that apart from the payments, they will be offered alternative employment with the sub-contractor to whom their respective departments have been outsourced.

Attempts to obtain comment from Liberty Life drew a blank, but according to Saccawu co-ordinator Joseph Mosi, the company said they have no comment.

Managers' fury over job losses

By Mzwakhe Hlangani
Labour Reporter

EMBATTLED black managers at insurance giants Fedsure Holding's wholly-owned Fedsure-Medway are embroiled in a legal tussle with the company after their positions were made redundant in a recent restructuring exercise.

A senior regional manager, Mr Ndhlabole Shongwe, together with eight sales managers, have taken the lead and instituted an unfair labour practice lawsuit with the Commission for Conciliation, Mediation and Arbitration (CCMA) against the company.

Shongwe described the actions by one of the company's senior executives as "unlawful and shabby" after he refused to consult with them and allow them to participate in meetings at his Cape Town home.

Legal representative for the com-

plainants, Mr Johan le Grange, confirmed this week that the matter had been taken up with CCMA since the company had displayed a "lack of the requisite *bona fides* and transparency" in implementing its restructuring process.

He said the plaintiffs were entitled to the maximum compensation in terms of the Labour Relations Act after satisfactory consultation.

Former sales managers Samuel Tshabalala, Moses Mogobobye, Clement Maubane and Nevson Rwodzi told *Sowetan* they were alerted to the fact that they were to be retrenched when a Mr Tim Southey, a representative for the holding company, had intervened on their behalf to arrange a meeting last month.

The company's spokesman, Mr Dave Jackson, was not available for comment yesterday despite many attempts to contact him.

(59) / 6/2/99

We won't axe 5 000 in city says Old Mutual

(59)
MD outlines cost cuts

THABO MABASO
STAFF REPORTER

ARG 24/6/99
Old Mutual managing director Gerhard van Niekerk has vehemently denied claims that the giant life assurer plans to cut head office staff by 5 000.

Mr Van Niekerk told the Cape Argus that Old Mutual was trying to reduce its total cost base by R500-million as part of a restructuring process called "Project 500".

But the effect of the restructuring process on staff would be minimal.

"We do not expect massive retrenchments," he said.

Areas that Mr Van Niekerk expected to be affected by the restructuring were the company's British operation, its agency distribution business and the employee benefits arm.

He said such areas as the rapidly growing unit trust business were expected to open up employment opportunities for staff, who would be redirected from the restructured operations.

An unnamed source at South African Commercial, Catering and Allied Workers' Union claimed earlier this week that Old Mutual planned to shed 5 000 employees as part of Project 500.

The unionist said most of the casualties from the restructuring would come from Old Mutual's Cape Town head office.

Saccawu Western Cape secretary-general Crosby Booie yesterday denied the allegations had emanated from his organisation.

"It took us by surprise, we did not make that statement," he said.

He said the union would investigate the source of the statement.

"What we know is that Old Mutual is in the process of restructuring certain business functions and we will make submissions with regards to that.

"We don't know anything about Old Mutual retrenching 5 000 employees," said Mr Booie.

Sources within Old Mutual reported that news of the pending retrenchments had resulted in staff becoming "very nervous and apprehensive".

Management had to spend most of yesterday reassuring staff that the reports were not true.

Internal squabbles forces likely Cosatu intervention

Reneé Grawitzky

THE Congress of SA Trade Unions (Cosatu) would intervene in an internal dispute in Sasbo, the finance union, which suspended its Johannesburg branch committee and assistant general secretary at Cosatu's special congress last week.

Amid claims of racism, a number of mainly black members from the union's Johannesburg branch were suspended for delaying an order not to attend the congress.

Sasbo general secretary Graham Rowan said a decision was taken to allow only the union's executive council to attend the Cosatu special congress because it was an unbudgeted cost. The Johannesburg branch said it would pay its own costs.

A Sasbo delegate said: "We wanted to attend so we could show the congress that Sasbo does have black members and is not a pure white union." The delegate said the union's leadership wanted only a white delegation to attend.

The assistant general secretary, Kenny Albertus, was suspended pending an internal investigation into the presence of the group from the Johannesburg branch.

Meanwhile, the three-day congress emerged with a draft programme of action to take forward a number of resolutions and declarations adopted which relate to job losses and the public service wage dispute.

The congress endorsed a decision to call on members of all 17 affiliates to join the countrywide

marches being held tomorrow by the public service unions affiliated to both Cosatu and the Federation of Unions of SA (Fedusa).

Countrywide marches were initially intended to put pressure on government to revise its final wage offer of R3,28bn.

Since government took a decision to implement the final offer, the action will also be directed against the move which the federation claims is an attempt to undermine the principles of collective bargaining.

The federation's broad programme of action includes campaigns on the shopfloor, provincial action to be finalised at a meeting this week and a full-blown general strike if demands on the issue are not met.

Before the congress, the federation submitted a notice to the National Economic Development and Labour Council (Nedlac) of its intention to embark on socio-economic protest action if demands linked to job losses were not addressed.

BD 23 | 8 | 99

Equity act will affect women

(179) (73) DD 18/8/99

The section that outlaws discrimination is a 'powerful tool', writes **Colleen Lowe Morna**

THE unveiling on Women's Day of the section of the Employment Equity Act that outlaws discrimination in the workplace was, to quote Labour Minister Membathisi Mdladlana, "another grinding stone, another powerful tool" in the struggle for gender equality.

Of the 14 forms of discrimination listed, four — gender, pregnancy, marital status and family responsibility — have a direct bearing on women.

The legislation both prohibits discrimination and obliges employers to present plans for positive measures that they intend to take to redress past imbalances. Diversity, as the minister emphasised at the launch, is not just a matter of human rights but also makes "good economic sense".

Where innovation, understanding customer needs, team work and consensus-based management are the name of the competitive game, hiring women is increasingly seen as good business. However, international experience also shows that legislation alone is not enough to right the wrongs of gender-based discrimination.

The majority of SA women are unemployed. They eke out a living in the so-called informal sector, where women predominate on the bottom rung: the survivalist sector.

Of those who work the largest number are domestic workers — one of the most powerless and exploited category of labour.

While there are roughly equal numbers of men and women in the public sector, women predominate in the lowest paid categories. Only 10% of those in decision-making positions are women.

In the private sector this figure is even lower.

According to the Central Statistic Service's Women and Men in SA, the earnings of white women average 60% of those of white men, while those of African women average 89% of African men. The average African women employees' earnings are 43% those of white women and 26% of the white male employee.

Gender-based discrimination begins at home, where girls are encouraged to play with dolls, be humble and submissive, while boys experiment with mechanical toys and are taught to be am-

bitious, assertive and outward-looking.

That carries through to school, where boys are given first preference, and predominate in the scientific, mathematical and financial fields of study.

Much of the discrimination against women in the formal sector is hidden and difficult to prove in court. For example, job adverts that emphasise travel and long periods away from home discourage women from applying because of their dual responsibilities.

Unfortunately, the Employment Equity Act does not begin to address one of the major structural causes of wage discrimination between men and women: the different weights which society assigns to the different types of work traditionally done by men and women. For example, a domestic worker responsible for raising children and managing a suburban home earns one-hundredth of her male boss's management salary; hair dressers earn less than mechanics and so on.

Studies elsewhere have shown that state supported pre-school facilities are indispensable to women's participation in the workforce. Yet only 1% of the education budget in SA goes to educate. Flexi-time is virtually nonexistent.

The result is that women predominate in part-time and casual employment, where wages are lower and chances of promotion are slim.

The gender opinion survey carried out for the Commission on Gender Equality recently showed that 69% of women spent more than two hours a day doing housework, compared with only 22% of men.

While the majority of respondents agreed that women should go to work — with men citing economic reasons — only one third of respondents supported affirmative action for women.

The new legislation does not set any specific targets for achieving gender parity in the workplace.

In the SA social climate it will take more than just a powerful tool to bring about a powerful change. Massive public education, accompanied by media exposure of good and bad company practices, are called for.

— Morna is CEO of the Commission on Gender Equality.

10 000 bank jobs on the line if two become one

UNMAN WARBY
STAFF REPORTER

(59)

AKL 16/11/99

Ten thousand jobs, from management down, are set to be the casualties of a possible takeover by banking group Nedcor of its larger rival Standard Bank Investment Corporation (Stanbic).

Nedcor has a staff of 18 000 and Stanbic 32 000, which, Nedcor chief executive Richard Laubscher estimates will be cut to a total of 40 000 in the next three years.

But the 10 000 jobs at stake were likely to be lost by natural attrition and not by retrenchments, although that possibility was not ruled out.

"The merger benefits will be achieved without significant layoffs," says Mr Laubscher. "There will be a natural attrition rate of 6 000 jobs a year among South African banks, so we believe retrenchments can be held to a minimum."

While Nedcor would try to retain key staff, it was unlikely to offer top

Stanbic managers - who had "put up such a spirited defence against the merger" - a role in the merged group.

Standard Bank spokesman Gareth Richards said staff morale was likely to be affected, with employees feeling their jobs may be on the line.

Finance Union SASBO demanded that the whole range of human resources and socio-economic issues be spelled out to unions before any merger took place.

SASBO has assured its members that no stone will be left unturned in the protection of their rights and the prevention of retrenchments.

Banking, Insurance, Finance and Assurance Workers' Union's secretary organiser David Lebelthe said that mergers were always indicative of job losses.

"We anticipate there will be retrenchments and that employee benefits will be curtailed should this merger go through," he said.

He called on those involved in the merger to consult employees, who were also stakeholders.

Merger could result in 10 000 job losses

Madeleine van Niekerk (59) 90 16/11/99

NEDCOR, SA's fourth-largest bank, says 10 000 jobs will be lost if the proposed merger between it and Standard Bank Investment Corporation (Stanbic) goes through, with the number of staff at the combined operation dropping from the current 50 000 to 40 000 in three years' time.

The number of bank branches will be reduced by 20% to 1 050 over the same period.

Most of the job losses would result from natural attrition and not retrenchments, Nedcor CE Richard Laubscher said yesterday.

The two groups employ a total of 51 000 people and have five million clients. The merger benefits would be achieved without significant lay-offs, Laubscher said.

"There will be a natural attrition rate of 6 000 a year among SA banks, so we believe that retrenchments can be held to a minimum," he said.

Nedcor said the two trade unions involved had been kept up to date with the latest developments on the proposed merger. The group said only 49 employees were retrenched when it closed 70 Perm branches.

The banking conglomerate is planning to acquire Stanbic on previous occasions, Nedcor continues to present the merger proposal as a friendly overture in line with the express wishes of many of Stanbic's shareholders.

The group denied it was staging a hostile take-over bid and insisted that it was still talking in terms of a "friendly merger".

If the bid succeeds, the merged group will be SA's largest bank with a market capitalisation of about R57bn, delivering cost savings of R3,1bn over the next three years.

Speaking at a luncheon

10 000 job losses expected

By Sapa-Net-Bridge and Shadrack Mashalaba (59)

NEDCOR officials have conceded that a merger with Standard Bank Investment Corporation (Stanbic) could result in as many as 10 000 job losses.

However, they believe that this will be absorbed as part of the natural attrition loss base figure of 18 000 over a period of three years.

These losses are expected at all levels. Nedcor argues that due to its experiences in handling merger processes, it can avoid such losses.

A merger will result in a total staff of about 50 000 but Nedcor believes the figure will have to be reduced to about 40 000 over three years.

It says the combined branch network will also have to be rationalised by about 20 percent to 1 050 branches countrywide.

Nedcor group chief executive Richard Laubscher says the merger will create a superbank that would withstand risks and compete internationally.

It would also improve opportunities for staff and management.

Meanwhile, Nedcor says it already has nearly 48 percent of the support of Stanbic shareholders to effect one of the biggest hostile takeovers.

However, the group denies it is staging a hostile takeover bid, insisting it is still talking of a friendly merger.

"We certainly don't consider our offer as hostile. It might be unsolicited."

Sapa-Net-Bridge 16/1/11 99

but it is certainly not hostile," says Nedcor chairman Chris Liebenberg.

"In spite of being rebuffed by Stanbic on previous occasions, Nedcor continues to present the merger offer as a friendly overture in line with the express wishes of many of Stanbic's shareholders."

Liebenberg says nearly 48 percent of Stanbic shareholders have already indicated their support for the merger. These included Old Mutual, Gencor, RMB Asset Management, BOE Asset Management and Coronation Fund Managers.

Stanbic said yesterday it was studying the offer. Nedcor group financial director Stuart Morris said there was a greater upside to a merger as opposed to a stand-alone situation.

Cosatu worried about job losses after merger

THE Congress of SA Trade Unions (Cosatu) expressed concern yesterday that Nedcor's bid to take over Standard Bank Investment Corporation would lessen competition in the banking sector and affect jobs.

Cosatu said it was worried about the affect on bank charges and interest rates and the effects extra running costs would have on job security.

It called on the Competition Board to investigate levels of job losses that would result from the planned merger and its impact on competition.

Cosatu said it was concerned to hear from its affiliate, the SA Society of Bank Officials (Sasbo), that the takeover threatened 10 000 jobs.

Cosatu said it supported Sasbo's call that discussion by the banks and unions be held before the merger is implemented.

The SA Chamber of Business (Sacob), on the other hand, said fears that a merger would lead to less competition in the banking sector were unfounded, Network Radio News reported. The trend in international retail banking was to merge and increase economies of scale, Sacob said. — Sapa.

(59) BD 17/11/99

4 Mergers: Cosatu wants inquiry

By Mizwakhle Hlangani
Labour Reporter

THE Congress of South African Trade Unions (Cosatu) has called on the competition board to probe the proposed merger between Standard Bank Investment Corporation (Stanbic) and Nedcor.

The labour federation made the call after warning that a marriage between the two banks could stifle

competition in the industry and encourage price fixing, which in turn could result in higher bank charges. This, it says, will be to the disadvantage of consumers.

Cosatu's concerns about the merger follow demands from its finance affiliate, the SA Society of Banking Officials (SASBO), for a "human resource protocol" to prevent job losses as a result of the merger. It has been estimated that the merger between the banks could result in the loss of 10 000 jobs.

It has also warned that the expected job losses in the banking sector will impede the objective of creating a superbank.

Federation spokesman Mr Mukoni Ratshtanga called on the banks' management to discuss the anticipated job losses with workers and the unions, since this presented a major challenge to the country. Cosatu also expressed concern at Nedcor's bid to take over Standard Bank for threatening 10 000 jobs, pointing out that the country

could not afford retrenchments.

Unemployment and job losses undoubtedly represent the biggest challenge to the country, he added.

Finance union SA Society of Banking Officials general secretary Mr Graeme Rowan also criticised the banks for avoiding the human resources and staffing issues before proposing the merger.

Rowan demanded a human resource protocol from Stanbic shareholders to halt job losses. He urged

shareholders to take a holistic view of the offer and not to "only consider the offer and not to 'only consider quick commercial enrichment'".

Cosatu also called on the competition board to investigate levels of job losses that will result from the merger and its impact on competition.

"Central to our concern is the worsening of monopoly which defined the feature of the banking industry and the country's economy," Mukoni added.

● See page 24.

Sowetan 17/11/99

Staff association backs Nedcor bid

ET(MR) 24/11/99 (59)

RICHARD STOVIN-BRADFORD

BANKING EDITOR

Johannesburg - The Insurance and Banking Staff Association (Ibsa), with between 5 000 and 6 000 members at Nedcor, as well as members at controlling company Old Mutual and other life offices, yesterday threw its weight behind Nedcor's hostile takeover offer for Standard Bank Investment Corporation (Stanbic).

Stanbic, which is fending off Nedcor's advances, last night said it would outline its "stand-alone" case tomorrow.

Ibsa, calling itself "the independent financial union", is predominantly a Nedcor staff association, market sources said. It has no known Stanbic members.

Ibsa said in a statement that from the business case presented by Nedcor it was apparent the merger would create a "dynamic

banking force" that could compete with international banks.

"Although this may initially lead to a reduction in staff numbers to effect economies of scale, in the long run it is bound to create job opportunities and scope for advancement," it said, citing the example of Nedcor's integration of Permanent Bank.

The bank tussle has fuelled emotive speculation in certain media and labour constituencies that the merger of Nedcor and Stanbic could cause 10 000 job losses. But the figure was only used by Nedcor in its synergy benefit assumptions and was largely predicated on natural staff attrition at the two banks.

Mike Leeming, an executive director of Nedcor, said last week: "We believe significant lay-offs are going to be avoidable because of a natural attrition rate of between 12 percent and 14 percent."

It is a common tactic of advisers to companies in hostile takeover bids to lobby trade unions and staff associations in an attempt, clearly successful in this case, to enlist their support.

Ibsa's stance is at variance with that of the Johannesburg branch of the South African Society of Banking Officials (Sasbo), the Cosatu-affiliated banking union, which last week adopted a resolution opposing Nedcor's takeover of Stanbic, saying "the resultant job losses would not be in South Africa's interests".

The branch told Sasbo nationally "to use its influence and power" to protect the jobs of Nedcor and Stanbic employees.

Ibsa said it had the assurance of Nedcor executives that "staff turnover and the shortage of skills" would be used to take care of the majority of redundancies that may arise.

Unions threaten legal action to prevent merger

Reneé Grawitzky (59)

THE Congress of SA Trade Unions (Cosatu) yesterday threatened to take legal action to prevent a merger between Nedbank and Stanbic.

Meanwhile, Stanbic announced that 3 000 jobs would be cut over the next three years.

Cosatu and Sasbo, the finance union, said they were exploring the possibility of interdicting Nedcor to prevent its hostile takeover bid of Stanbic.

Cosatu general secretary Zwelinzima Vavi said the federation rejected and condemned moves by Stanbic which Nedcor has said would result in

the loss of up to 10 000 jobs.

The decision to consider legal action, including the possible interdicting of the takeover, had been taken during the federation's central executive committee meeting this week.

The federation said the proposed merger would not be in the interests of the economy as it would create a "near-monopoly dispensation in the banking industry". Cosatu said a proposed interdict will be considered if Nedcor has failed to comply with labour legislation or the rules of the competition board. Nedcor had failed to engage in a proper consultation process with workers or the union on the proposed merger.

Cosatu said Sasbo had refuted public claims that the union had been fully consulted on the merger. The union was privy to a video presentation and leaflets of the companies plans.

"At no stage was there an attempt to conduct a genuine process of consultation", Cosatu said.

Meanwhile, Stanbic CEO Jacko Maree acknowledged yesterday that there would be job losses in banking, saying the bank was looking at a "headcount reduction" of about 1 000 a year over the next 3 years. "But this is a lot less than what would emerge from a merger," he said. Nedcor are looking at a loss of about 10 000 jobs in a merged entity.

Sasbo condemns Nedcor's tactics

ARG 27/11/99

(79)

RICHARD STOVIN-BRADFORD

BANKING EDITOR

Johannesburg - The South African Society of Bank Officials (Sasbo), the finance union, has slammed the handling of Nedcor's bid for Standard Bank Investment Corporation (Stanbic).

In a firmly worded letter from Sasbo to Mike Leeming, Nedcor's chief operating officer, Graeme Rowan, Sasbo's general secretary, said the union's main concerns were its members' job security, the urgent need to create rather than destroy jobs in South Africa, and the future welfare and stability of the finance industry.

"We have always had the greatest respect for Nedcor and the manner in which it has conducted its human relations, but the tactlessness of the past week has fuelled fears that Nedcor has regarded Sasbo as nothing more than an ineffectual worker voice to be fobbed off with the scantest of information on an issue of major concern to the economy."

But, despite Sasbo's obvious ire, Rowan did not compromise Sasbo's future impartiality. "We shall continue to allow both Nedcor and Stanbic equal opportunity to air their views on the issue at any future meetings that may take place."

Earlier this week the Insurance & Banking Staff Association (Ibsa), the self-proclaimed "independent financial union", supported Nedcor's takeover bid but chose not to reveal its real role as Nedcor's staff association.

Ibsa's statement was further evidence that the Nedcor bid machine was upping its game on a broad front. It emerged this week that Leeming had told the remuneration manager at Nedcor Park in Selby, Johannesburg, to send out a memorandum advising staff of a voting line operated by Business Report's sister paper.

It read: "The Star daily newspaper has opened a voting line for people to voice their opinions regarding the proposed merger. ... The voting pole (sic) closes this afternoon at 5pm."

Rowan in particular objected to a letter from Nedcor which claimed labour had given its blessing to Nedcor's bid: "Sasbo, the major player in finance sector trade unionism, has never been consulted for input insofar as the bid has been concerned."

"All that has occurred is that Nedcor has given our union prior notification - sometimes as little as 20 minutes - of management's intentions."

Labour federation says it's war if Nedcor takes over Stanbic

Cosatu digs in its heels on bank bid

FRANK NXUMALO AND
RICHARD STOVIN-BRADFORD

Johannesburg – Cosatu yesterday threatened war if Nedcor's bid for the Standard Bank Investment Corporation (Stanbic) went ahead.

Also yesterday Nedcor fired another salvo in the battle to gain territory in what has deteriorated into a debate over which bank's merger assumptions and attitude are more realistic.

"Cosatu will go to war to support the South African Society of Bank Officials (Sasbo) members who risk losing their jobs through the implementation of the takeover which appears to be at odds with monopoly legislation and the spirit of the social plan launched on Monday night by the minister of labour," said Makhoni Ratshtanga, the Cosatu spokesman.

The labour federation said it was aware that Sasbo – its finance affiliate that is apparently opposed to the bid – had internal problems, but warned that these should not be used to "discredit the union's right to take up legitimate concerns of its membership."

But leading and ordinary members of Sasbo expressed anger at Graeme Rowan, the union's general secretary, for misrepresenting in a media statement the resolution taken at last week's annual general meeting as an anti-merger stance.

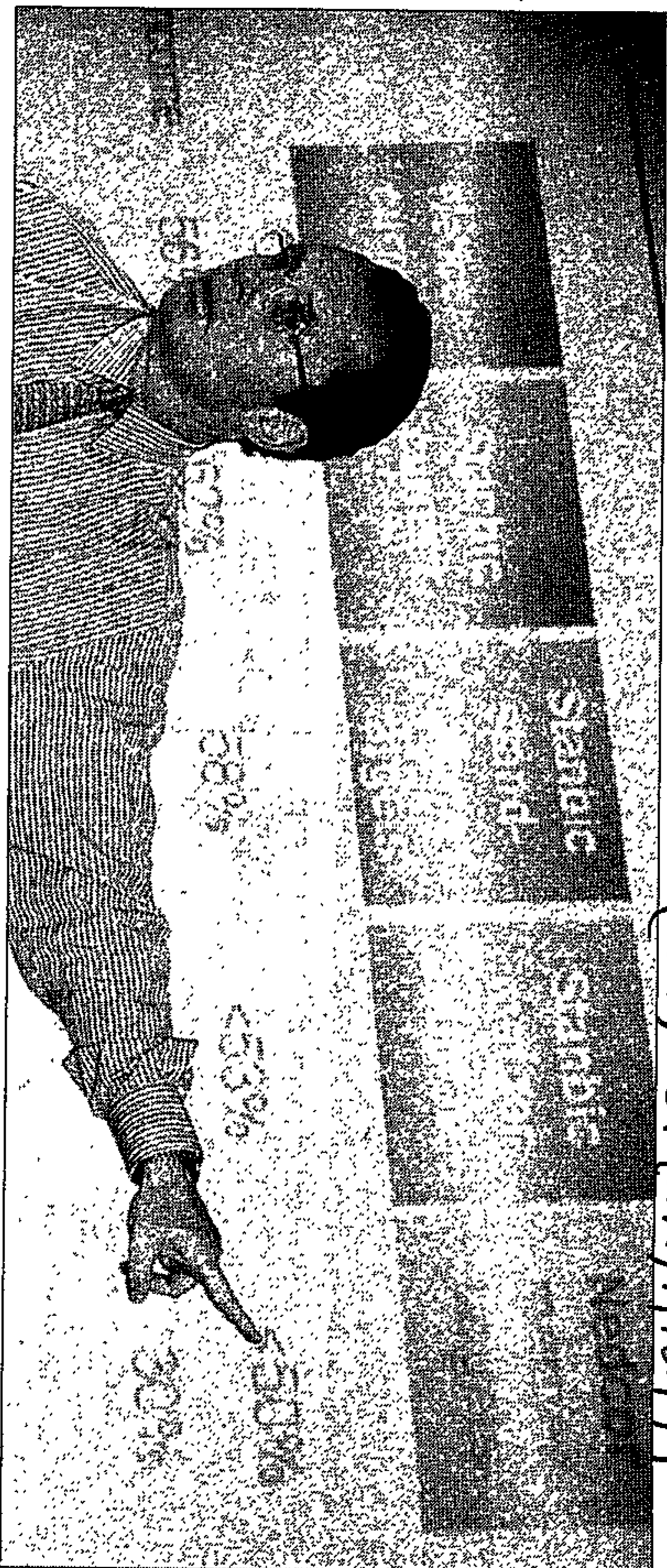

MY WAY Nedcor's Richard Laubscher took his chance yesterday to say why he thinks Stanbic's standalone strategy is not without risks. He compared it with NatWest, the underperforming British bank that was recently put into play by competing bids from two smaller and more efficient Scottish banks

"The resolution taken at the Johannesburg AGM was never against the merger between the two banks," said George Selebi, the chairman of the Sasbo Johannesburg branch committee and the national president.

"The only objection we had was the potential loss of 10 000 jobs. The general secretary was instructed to use all that was within his powers to stop job losses. I hereby wish to distance myself from the press report released by the general secretary of the union," said Selebi.

In a hard-hitting presenta-

tion Richard Laubscher, Nedcor's chief executive, criticised Stanbic's preference to remain independent on fears of merger risks, arguing that a "stand-alone Stanbic" was hardly a low-risk operation.

He said this was demonstrated in Stanbic's history of credit problems, its "high-risk" London exposures, its "unimproved" bancassurance strategy, its lack of a cost-reduction track record or skills and the fact that one-third of its bottom-line growth came from reduction in credit loss provisions.

Comparing and contrasting Stanbic's higher cost-to-income ratios and lower return on equity with Nedcor's own stronger performance, he asked: "Where do you want to be?"

Laubscher drew the strongest parallel yet between Stanbic and NatWest, the underperforming British banking major that was recently put into play by competing bids from two smaller and more efficient Scottish banks.

Nedcor has long used Lloyds TSB, Britain's most profitable bank, as its benchmark.

"If you're one of the (top performing staff at Lloyds TSB or NatWest) where would you rather be?"

"Every time you open a paper, there's another disaster (at NatWest)."

In a renewed bid to quell staff concerns, he said: "Every staff member who's on-side will have a place in the sun."

But he emphasised he would not allow Nedcor's takeover to be hijacked by hostile Stanbic executives.

□ Business Watch, Page 2

PHOTO JOHN WOODROOF

Union takes umbrage at Nedcor

(59)

FRANK NXUMALO

ET (BR) 2/12/99 LABOUR EDITOR

Johannesburg - The strained relations between the South African Society of Banks Officials (Sasbo), the Cosatu affiliated finance union, and Nedcor over the latter's hostile bid for Standard Bank Investment Corporation (Stanbic) took a knock yesterday, with Sasbo accusing the bank of trying to forge a "clumsy alliance" with union dissidents.

Sasbo said it had "noted with disdain" Nedcor's consorting with a "disgraced president who has been suspended by his colleagues for indiscipline, abusiveness and the use of foul language".

Sasbo was at odds with George Selebi, its president, for claiming that an anti-merger stance was never taken at the annual general meeting of the union's Johannesburg branch last week.

Selebi told Nedcor the meeting had instructed Graeme Rowan, the union's general secretary, to do everything possible to save an estimated 10 000 job losses over three years that could result from the proposed merger.

"The bank obviously wants to decoy Nedcor and Standard Bank employees from the real issues if the present Nedcor regime gains control," Rowan said. "The resolution deploring Nedcor's acquisition was read to the meeting no less than four times and it was Selebi who supervised the voting process, there was not a single dissenting vote."

He said Selebi needed to explain his departure from Cosatu's position on mergers and job losses.

Selebi declined to comment.

LABOUR *International federation writes to Nedcor*

Sasbo wins support for its anti-merger stance

CT(OR) 3/12/99 (59)

FRANK NXUMALO

LABOUR EDITOR

Johannesburg - The South African Society of Bank Officials (Sasbo), the Cosatu-affiliated finance union that opposes Nedcor's hostile bid for Standard Bank Investment Corporation, received a pledge of support yesterday from the International Federation of Commercial Clerical Professional and Technical Employees (FIET).

FIET represents 10 million members in the finance industry in more than 400 trade unions from 135 countries.

Sasbo has estimated that more than 10 000 bank jobs could be lost over three years because of the proposed banking merger.

"FIET cannot accept a takeover that has such savage repercussions on staff and their families," Philip Jennings, the general secretary of FIET, said in a letter to Chris Liebenberg, the chairman of Nedcor.

"Our affiliate Sasbo has no option but to take whatever action is deemed necessary to protect employment. We support the Sasbo campaign."

Jennings said South Africa could ill afford such a devastating blow to job prospects.

"All possibilities should be

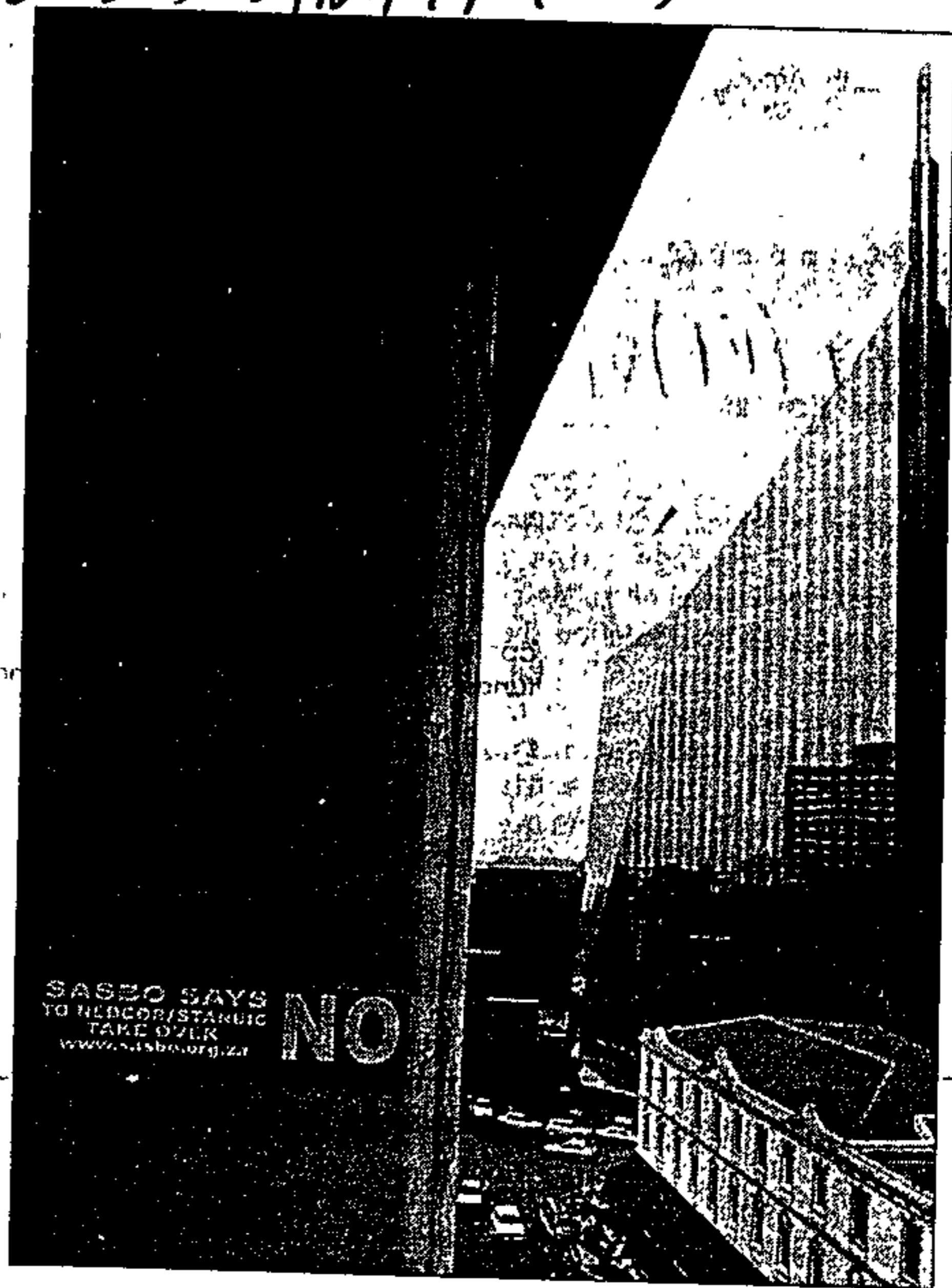

AGAINST THE WALL A Sasbo campaign sticker in downtown Johannesburg shows the union's feelings about potential job losses

PHOTO SELWYN TAIT

explored to introduce a fair, comprehensive social contract that avoids these horrendous

job losses," Jennings said.

Nedcor could not be reached for comment.